

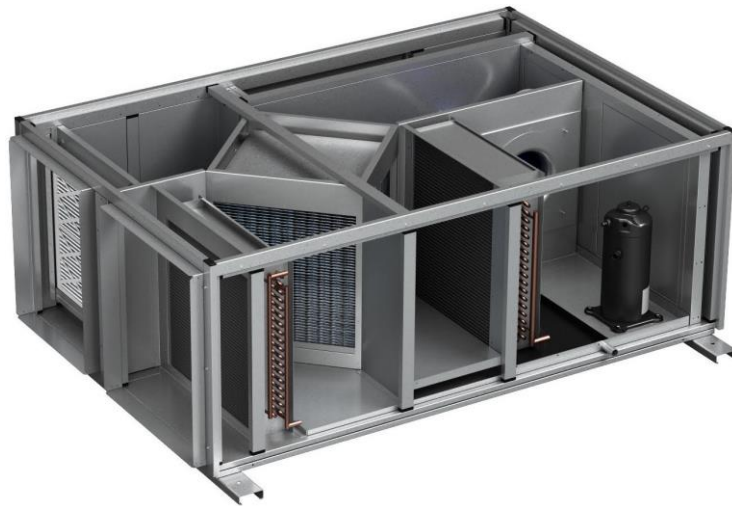

**DRY**COMFORT  
dehumidification solutions

**COLD**WAVE  
refrigeration solutions

# INSTALLATION & OPERATION MANUAL



Q4 ENERGY SOLUTIONS, INC.

214 HOFF ROAD, SUITE H,  
WESTERVILLE, OH 43081  
614.392.0741

# Table of Contents

- SAFETY WARNINGS ..... 4**
  
- OVERVIEW ..... 5**
  - Principle of operation..... 5
  - Plan view drawing ..... 6
  
- INSTALLATION ..... 6**
  - Drain trap ..... 6
  - Unit support..... 7
  - Connecting the keypad/display ..... 8
  
- OPERATION ..... 9**
  - Pre Start-Up Checklist..... 9
  - Operating the DryComfort unit ..... 9
  - Operating keypad/display ..... 10
    - Display ..... 10
    - Keypad buttons..... 10
    - User interface navigation ..... 11
  - Setting the room dew point..... 11
    - Selecting a space dew point set point ..... 12
  - Allow the unit to run continuously..... 12
  
- SEQUENCE OF OPERATION ..... 13**
  - Unit start command ..... 13
  - Unit stop command ..... 13
  - Unit HOA modes ..... 13
  - Dehumidification set point ..... 13
  - Dehumidification mode..... 13
  - Suction line pressure low limit function ..... 14
  - Suction line pressure high limit function ..... 14
  - Discharge line pressure high limit function ..... 14
  - Refrigeration pressure high and low limits alarms ..... 14
  - Phase loss alarm ..... 14
  - Alarm indication..... 14
  
- MORE ►**
- KEYPAD/DISPLAY SCREENS ..... 15**

**MAJOR COMPONENTS..... 17**  
    Flat plate heat exchanger ..... 17  
    Refrigeration circuit ..... 17  
    Controls section ..... 17  
Controller and keypad/display ..... 17  
    Humidity/temperature sensor ..... 18  
    Indicator lights ..... 18  
    Fans ..... 18

**MAINTENANCE ..... 19**

**REPLACEMENT PARTS ..... 19**

**TROUBLESHOOTING..... 20**

**WARRANTY ..... 21**

**CONTACT US / MORE INFORMATION ..... 22**

## SAFETY WARNINGS

### WARNING

#### **Arc flash and electric shock hazard, which can cause serious injury or death**

Disconnect all electric power supplies and wear protective equipment per NFPA 70E before working within electric control enclosure . Lock and tag the disconnect switch or breaker to prevent accidental re-connection of electric power while performing service or maintenance operations . Failure to comply can cause serious injury or death . Customer must provide earth ground to unit, per NEC, CEC, and local codes, as applicable . Before proceeding with installation, read all instructions, verify that all the parts are included and check the nameplate to be sure the voltage matches available utility power . The line side of the disconnect switch contains live high-voltage . The only way to ensure there is NO voltage inside the unit is to install and open all local and remote disconnect switches and verify that power is off with a volt meter . Refer to unit electrical schematic . Follow all local codes .

### CAUTION

#### **Extremely hot surfaces, which can cause injury**

Motors and other electrical parts are extremely hot during unit operation . Allow sufficient time for them to cool before working within the unit cabinet . Use extreme caution and wear protective gloves and arm protection when working on or near hot components . There are no user serviceable parts in the interior of this unit . Servicing of this unit is to be performed only by a qualified HVAC technician .

## OVERVIEW

The DryComfort dehumidification unit is designed specifically for supermarket applications . The DryComfort unit's integral heat exchanger efficiently returns warm dry air to the space (typically a freezer aisle) using 30% less cooling capacity than a dehumidification unit that does not have a heat exchanger.

### Principle of operation

- 1 The DryComfort unit draws warm, humid room air into the heat exchanger, transferring sensible heat to the heat exchanger . Cooled, moist air moves to the dehumidification coil.
- 2 Air passes through the dehumidification (direct expansion) coil where it is further cooled and dehumidified.
- 3 Air passes through the heat exchanger where it is warmed by the previously captured sensible heat .
- 4 Air passes through the condenser coil for additional sensible heating .
- 5 Warm, dehumidified air enters the space .

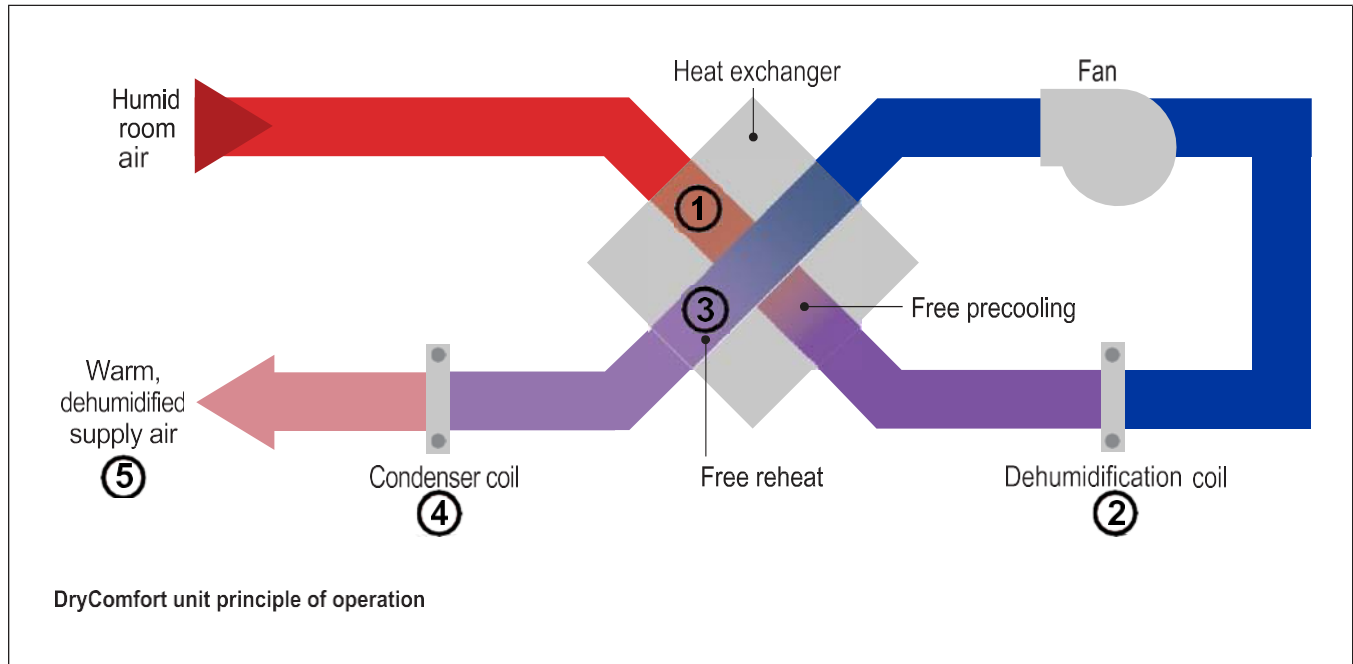

## Plan view drawing

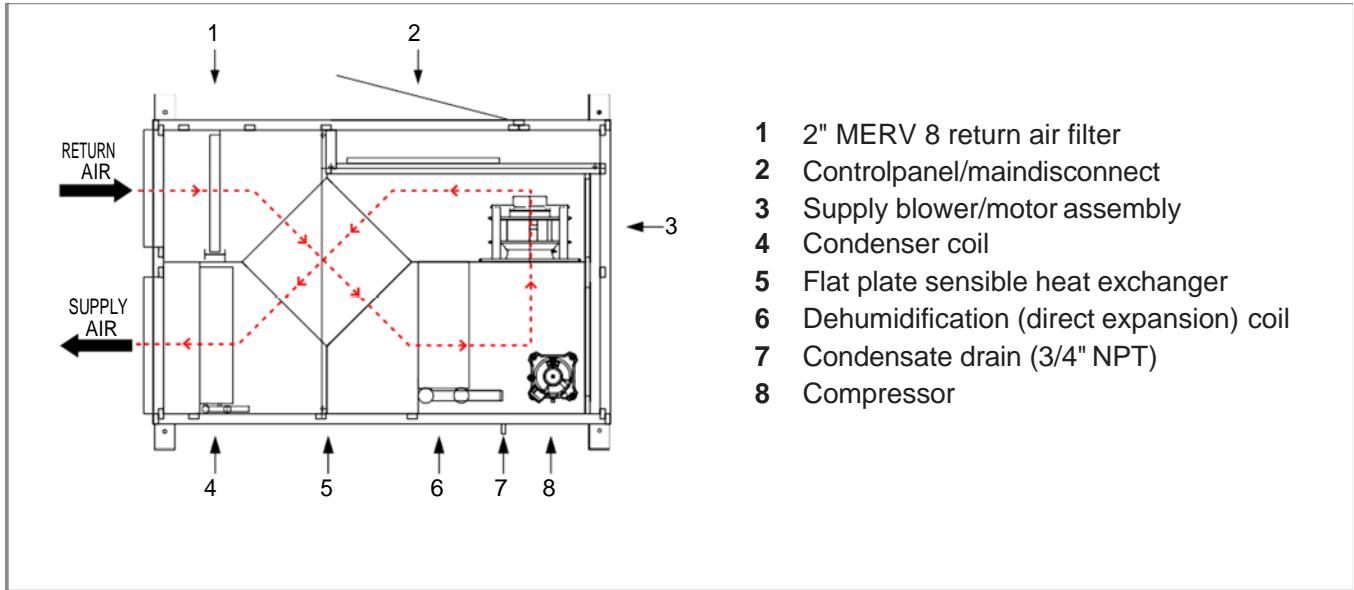

## INSTALLATION

See the drawing on page 7 .

- When suspending the DryComfort unit use support hardware provided by others .
- When suspending the DryComfort unit, always suspend from building structural elements such as beams or joists . Before beginning unit installation, verify the suitability of supporting structural elements . If necessary, have the proposed installation location inspected by an engineer for suitability and verification of load bearing capacity . Each DryComfort unit weighs approximately 800 pounds.
- The DryComfort unit has support points at each corner . Attach 5/8"-diameter threaded rods at each corner support point . Extend each threaded rod upwards and suspend it from a hanger-type vibration isolator hung from Unistrut-type support channels . These support channels must be anchored to all beams or joists that they span in order to spread the load over a greater area . The spot where each threaded rod is installed in the channel must be supported by a joist or beam on both sides .

## Drain trap

Recommended drain trap design  
(trap by others)

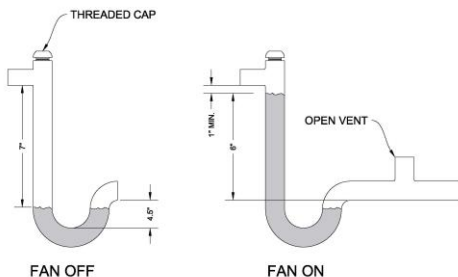

**IMPORTANT: Drain Trap Note**  
Threaded vent cap on P-Trap is for ease of priming to assure proper condensate flow.

## Unit support

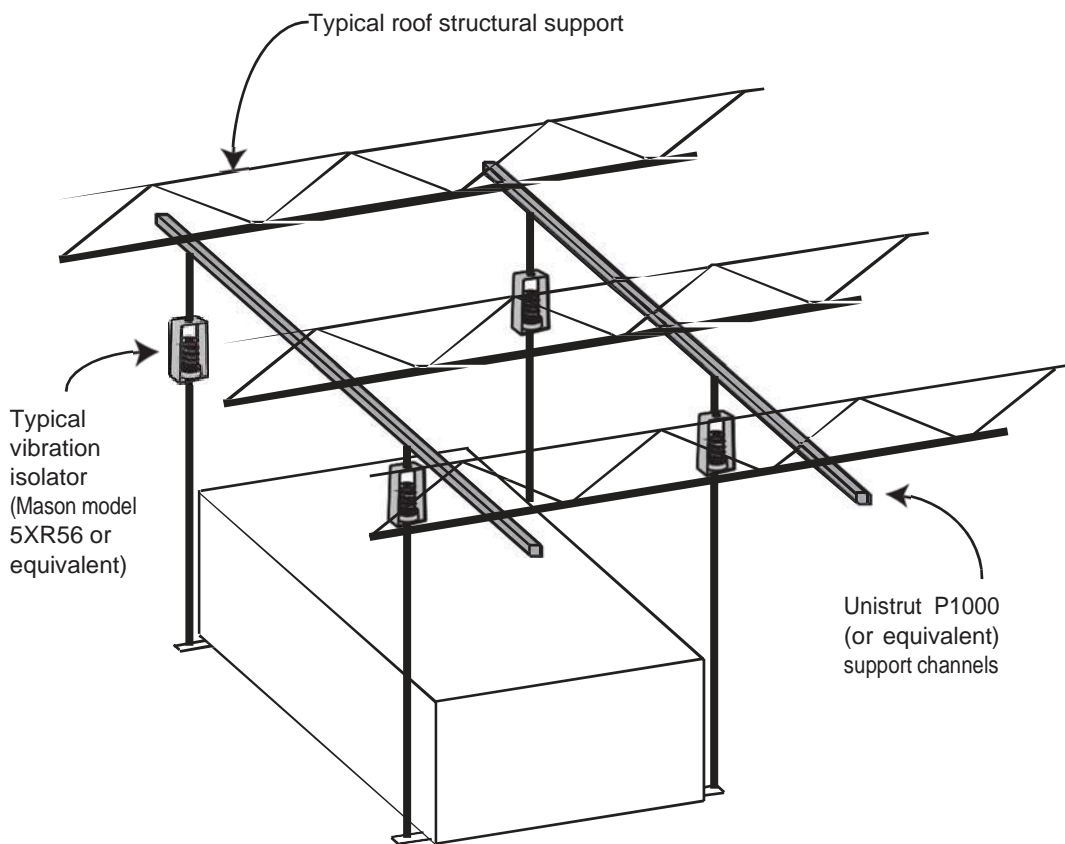
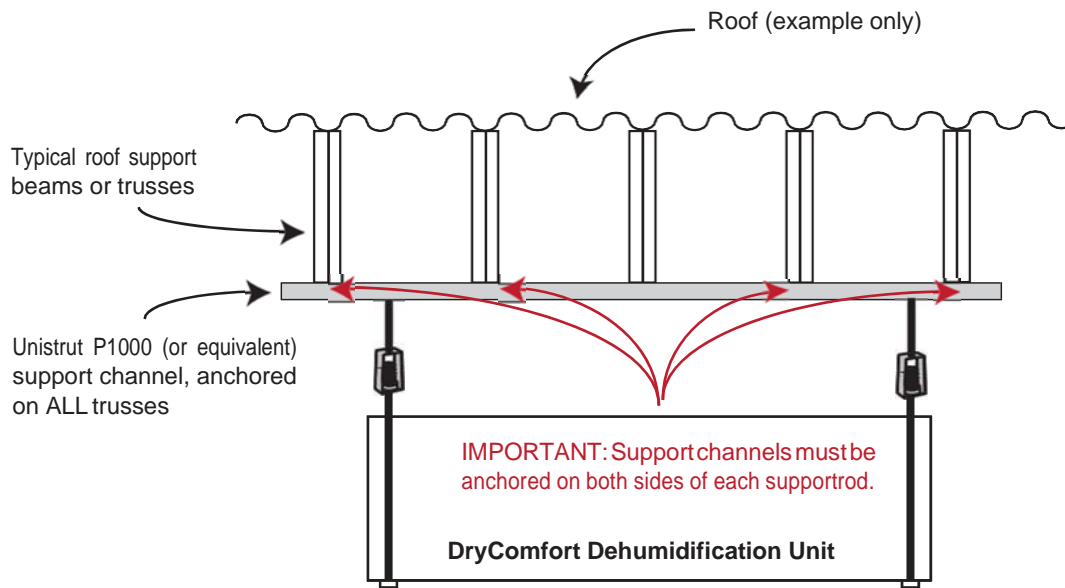

- Select location for unit based on proper clearances, access and visibility.
- Avoid locations where other equipment may be installed on the same structural supports.
- Install Unistrut P1000 (or equivalent) support channels, anchoring them to all structural supports.
- Install hanger-type vibration isolators on 5/8"-dia. threaded rods.
- Hang unit from vibration isolators on 5/8"-dia. threaded rods.
- Level unit.

## Connecting the keypad/display

The keypad/display is connected to the controller by a straight-through six conductor cable with RJ45 jacks on each end. The keypad/display is intended to be secured in the main control panel, but it may also be installed (by others) in a location that is convenient to the owner, but not more than 164 feet (50 meters) away from the controller.

A factory-supplied 6-wire straight-through cable provides data transmission and power for the keypad/display . Connect this cable to the back of the keypad/display and to the J10 port of the controller . The keypad/display and its connecting cord are secured inside the main control panel during shipment of the unit.

**Note:** The keypad/display is used typically as a hand-held device, but may also be mounted on a wall or other surface using the screw-head recesses on the back of the device .

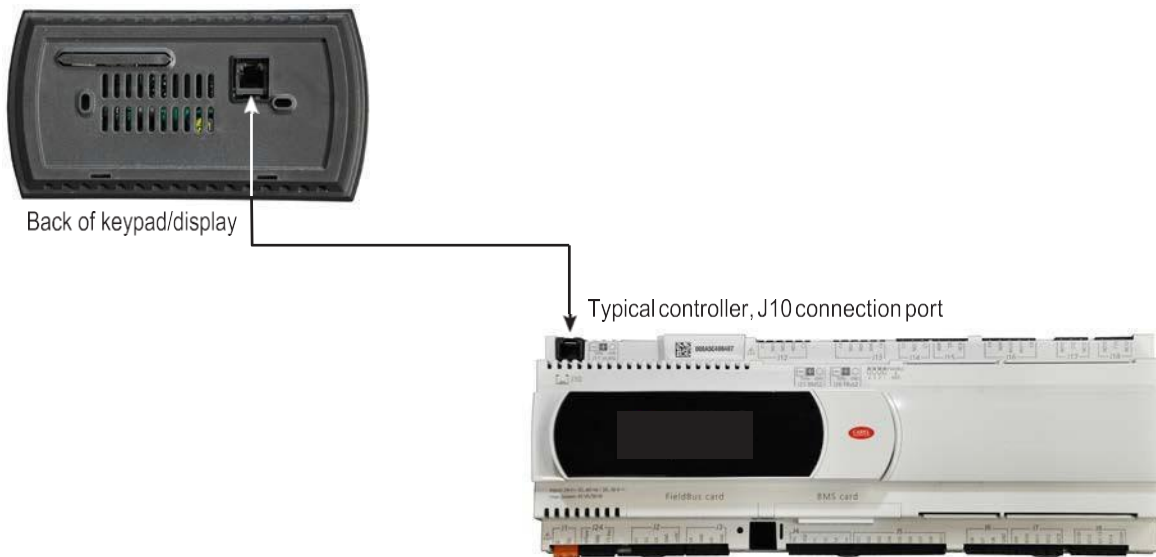



# OPERATION

## Pre Start-Up Checklist

Complete prior to application of power.

Duplicate this checklist and complete one for each unit .

### ATTENTION:

Send this completed form to Q4 at least two weeks prior to requested unit start-up date .

Date	
Job name	
Job number	
Serial number	
Unit tag number	

### General requirements for all units:

- Clean up all installation / construction debris .
- Before connecting power to the unit verify that the supply voltage is the same as the rated voltage on the unit.
- Connect the keypad/display to the controller . See page 8 of this manual .
- Verify permanent main power is connected to unit disconnect .
- Verify that ductwork system has been installed complete enough to permit unit operation .
- Verify that the condensate drain line for the heat exchanger/cooling coil is connected .
- Verify that a condensate drain trap has been installed and primed .
- Verify that the controls contractor has been notified for start-up (if applicable) .
- Verify that air side balance is coordinated (air balancing takes place after start-up) .

## Operating the DryComfort unit

The DryComfort unit is operated by a preprogrammed, factory-installed controller . Once the DryComfort unit is installed and switched on, the DryComfort unit automatically controls and constantly monitors unit operation using various sensors . The controller regulates fan speed and refrigeration system operation to maintain cooling coil leaving temperature set point . The controller has one main set point: room dew point . This set point is the dew point at which room air is to be held . The desired dew point can be adjusted by the user . All changes to the controller are made via the buttons on the keypad/display .

## KEYPAD/DISPLAY

The keypad/display is connected to the controller by a straight-through six conductor cable with RJ45 jacks on each end. The keypad/display is intended to be secured in the main control panel, but it may also optionally be installed (by others) in a location that is convenient to the owner, but not more than 164 feet (50 meters) away from the controller. A 50-foot long connecting cord is provided with each unit shipped.

### Display

The keypad/display has a monitor screen that is the graphical user interface for the controller. The user selects and views data and information on the screen and then, when desired, makes changes to the dew point set point.

### Keypad buttons

All changes to the controller are made using the six buttons on the face of the keypad/display. The buttons are:

- Alarm
- Prg (Program)
- Esc (Escape)
- Up arrow
- Enter
- Down arrow



Keypad/display

## User interface navigation

In order to access data from the controller or to make any changes to the dew point set point, it is necessary to navigate through the screens found on the keypad/display. This is done using the keypad/ display's buttons.

□	Pressing the <b>Prg</b> (program) button accesses the <b>Main Menu</b> from any location in the user interface screens .
□	The <b>Esc</b> button is used to go one level back from the screen the user is currently on . If finished setting a variable, the <b>Esc</b> button takes the user back to the previous menu . If the user is editing a variable and decides not to make a change, the <b>Esc</b> button takes them back to the top of that screen .
↑	In a menu, the <b>Up</b> and <b>Down</b> buttons scroll through available options . While editing a variable, the <b>Up</b> or <b>Down</b> buttons allow the user to set the desired value of the variable .
↓	
↩	When a menu or menu item has been highlighted, press the <b>Enter</b> button to enter the highlighted selection . When a writable entry has been changed, press the <b>Down</b> button to enter the new value and then press it again to confirm the change .
□	Pressing the <b>Alarm</b> button displays alarms that are currently active . Pressing the button a second time jumps to the <b>Alarm Reset</b> screen .
<b>Note:</b> If the unit is in alarm, the Alarm button will be flashing .	

## Setting the room dew point

The room dew point represents the amount of moisture in the room. Relative humidity is based on the temperature of the room, which is controlled by other refrigeration systems, and represents the amount of moisture room air contains in relation to the amount of moisture room air can hold.

Use Table 1 on page 12 to select a dew point set point based on room temperature and relative humidity.

To set the room dew point:

- Turn on the service switch. The **Main Menu** screen, shown below, appears on the keypad/display.



- Press the **Down** arrow button to move to the **Room DewPt Setpoint** screen, shown below.

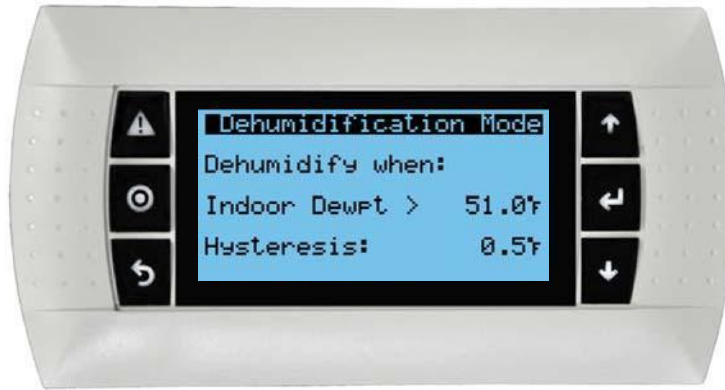

- Press the **Enter** button to access the **Room DewPt Setpoint** screen.
- Press the **Up** or **Down** arrow to change the dew point temperature.
- Press the **Enter** button again to accept the new dew point setting.

## Selecting a space dew point set point

Use the table below to select a dew point set point based on the desired room temperature and relative humidity.

Table 1: DryComfort dew point set point									
Room temp °F	Relative humidity %RH								
	30	35	40	45	50	55	60	65	70
69	36	40	44	47	50	52	55	57	59
70	37	41	45	48	51	53	56	58	60
71	38	42	45.5	49	51.5	54	56.5	59	61
72	39	43	46	50	52	55	57	60	62
73	40	44	47	50.5	53	56	58	61	63
74	41	45	48	51	54	57	59	61.5	64
75	41.5	45.5	49	52	55	58	60	62	65
76	42	46	50	53	56	59	61	63	65.5
77	43	47	51	54	57	60	62	64	66
78	44	48	52	55	58	60.5	63	65	67
79	45	49	53	56	59	61	64	66	68

**Note:** Allowable space dew point set point range for the DryComfort unit is 45 °F – 55 °F.

## Allow the unit to run continuously

The DryComfort dehumidification unit is intended to run continuously . If there is no need for dehumidification for an extended period (such as if the room will be empty for an entire season), turn the service switch to **OFF**.

## SEQUENCE OF OPERATION

The stand-alone controller shall perform the following sequence:

### Unit start command

- Disconnect switch in “On” position
- HOA switch in “Hand” position, or HOA in “Auto” position and commanded on through BMS
- Dehumidification operation per below

### Unit stop command

- Disconnect switch in “Off” position, HOA switch in “Off” position, or unit commanded off through BMS and HOA in “Auto” position
- Fans and compressor are de-energized

### Unit HOA modes

- In “Hand” mode, the unit shall run according to the locally programmed set points and the BMS, if present, will be used for monitoring only . The green LED will be solid while the unit is running in “Hand” mode . The red LED will be solid only when there are alarms present .
- In “Auto” mode, the unit shall run according to the BMS set points . If the BMS goes down, the unit will revert to the locally programmed set points and the controller will alarm over the missing BMS . The green LED will be solid while the unit is running in “Auto” mode and if the BMS has commanded the unit off, the green LED will flash periodically .

### Dehumidification set point

- The controller shall energize the dehumidification mode when the return (room) air inlet humidity increases above the dehumidification set point (set points adjustable at the keypad/display)
  - Dehumidification Mode Dew Point Set Point (factory set point = 51; +2 °F dead band; adjustable from the keypad/display)
  - BMS to provide return (room) dew point set point through BACnet
    - Dew point range: 45–55 °F

### Dehumidification mode

- On a call for dehumidification, the controller shall energize the dehumidification mode:
  - Maximum Dehumidification Capacity:
    - Supply fan runs continuously
    - The dehumidifier shall cycle the compressor on/off to maintain the return (room) air inlet humidity at set point . There shall be a minimum on/off time to prevent short cycling of refrigeration system (600 sec, adjustable) .
    - When energized, the compressor shall modulate to maintain a constant discharge air temperature leaving the DX coil . DX coil leaving air temperature set point = 39 °F (set point adjustable at the keypad/display)
    - If the cooling coil fin temperature sensor reads 35 °F or lower for more than 5 minutes, the cooling coil discharge air temperature set point shall be reset to 42 °F for 15 minutes then reset back to 39 °F once the cooling coil fin temperature sensor has increased above 35 °F .

## Suction line pressure low limit function

- If the suction pressure drops below 95 psi, the compressor capacity command will be reduced . The compressor capacity command is reduced from its current command down to a minimum of 25% as the suction pressure drops from 95 psi (29 °F) to 85 psi (24 °F), the low pressure limit . Function: prevent low refrigeration pressure trips, freezing of the DX coil, and operation outside the operating envelope of the compressor .

## Suction line pressure high limit function

- If the suction pressure increases above 170 psi, the supply fan airflow will be reduced . The supply fan airflow command will be reduced from its current command down to a minimum of 25% as the suction pressure increases from 170 (60 °F) to 180 psi (63 °F), the high pressure limit . Function: prevent compressor operation outside the compressor operating limit .

## Discharge line pressure high limit function

- When the discharge line pressure rises above 475 psi, the compressor capacity command will be reduced . The capacity command is reduced from its current command down to a minimum of 25% as the discharge line pressure rises from 475 (130 °F) to 550 psi (145 °F), the high pressure limit. Function: prevent compressor operation outside the compressor operating limit .

## Refrigeration pressure high and low limits alarms

- If the refrigeration system high and low pressure limits listed above are exceeded, the controller shall signal an alarm condition and turn on the red alarm lamp . The red alarm lamp shall automatically reset when the alarm condition no longer exists . Three alarms within a one hour period shall hold the red alarm lamp on .

## Phase loss alarm



- If the phase loss protector indicates loss of phase, the unit shall be de-energized and the controller shall signal an alarm condition and turn on the red alarm lamp . The unit shall automatically restart when phase loss alarm has cleared .

## Alarm indication

- Alarm indications are indicated by the red alarm lamp on the front of the control panel . All alarms shall be viewable from the Remote User Terminal.

## KEYPAD/DISPLAY SCREENS

**Main Screen.** Shows (clockwise from the bottom left corner), space dew point set point, the current space dew point, other sensor values such as the supply temp, and component/mode status images that represent cooling, dehumidifying, and fans.

Laser Dehumidifier	
SPACE DEWPT 52°F	SUPPLY TEMP 94°F
SPACE DEWPT STPT 51°F	  
Dehumidifying	

**Dehumidification Screen.** Shows information for assessing current status of the space and the dehumidification operation of the unit.

Dehumidification	
Status: Enabled	
SUP Dewpt:	39.2°F
Supply Temp:	93.7°F
Space Dewpt:	51.6°F
Dewpt Setpt:	51.0°F

**Space Air Conditions Screen.** Provides an overview of the space including temperature, humidity, enthalpy and dew point.

Space Air Conditions	
Temp:	74.2°F
Humidity:	45%
Enthalpy:	26.8btu/lb
Dewpoint:	51.6°F

**Supply Fan Status Screen.** Shows if the unit has commanded the fan on, what capacity it is driving the fan, and if the fan has been proven to be running.

Supply Fan Status		
COMMAND	SIGNAL	STATUS
1: On	92%	On

**Cooling Ramp 1 Status Screen.** Shows coil leaving set point, coil temperature, cooling ramp state, and the capacity of the compressor that is currently being utilized.

Cooling Ramp 1	
Setpoint:	39.0°F
Coil Temp:	39.2°F
Ramp:	Enabled 7%
Capacity:	10%
Details: Press ENTER	

**Compressor Request Screen.** Shows if the compressor is on and what capacity it is currently commanded to operate at. The compressor will always be regarded as Ramp 1 and will be on Circuit A.

Compressor Request		
COMP CALL	RAMP	CIRCUIT
1: On 10%	1	A

**Circuit A Status Screen.** Displays several sensor readings that are important to diagnose and monitor the refrigeration system, including suction and discharge pressure readings, and calculated saturation temps.

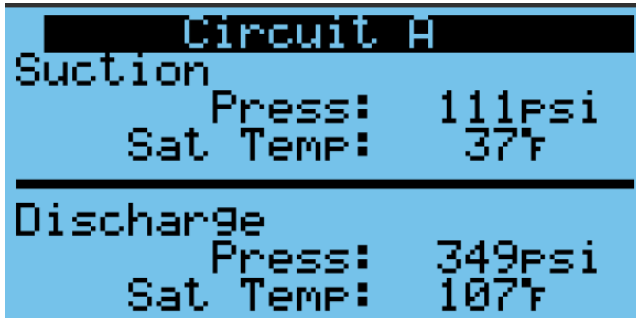

**Active Protection Mode Screen.** Shows the status of protection loops . If the system determines that there is a too high discharge temp, a too low suction temp, a too high suction temp, or a too low coil fin temp, the unit will automatically scale back the compressor or the fan in order to continue to operate without cutting off completely. If the main screen displays that a protection mode is active, this screen will identify it.

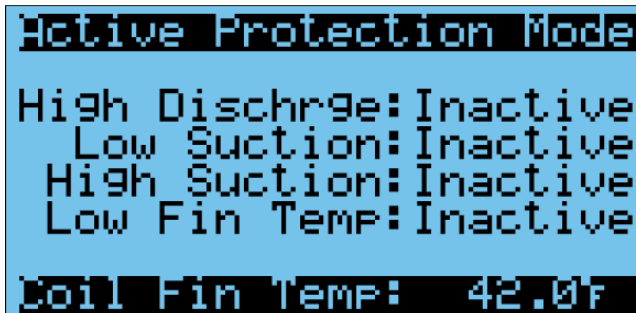

**Input Output Status Screen.** Used to view and select input and output values on the unit controller.

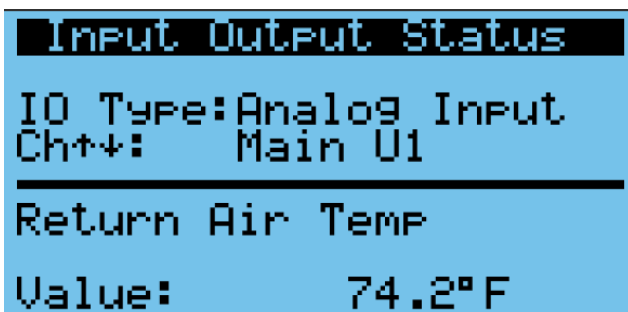

**Main Menu Screen.** The Program button brings up the Main Menu screen. To change the space dew point set point, scroll down and select User Settings.

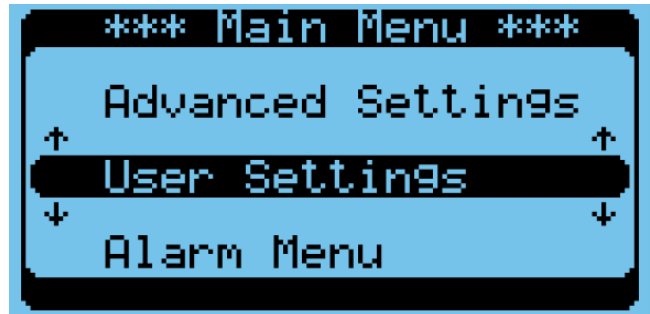

**Dehumidification Mode Screen.** Used to select dew point set point and to change hysteresis.

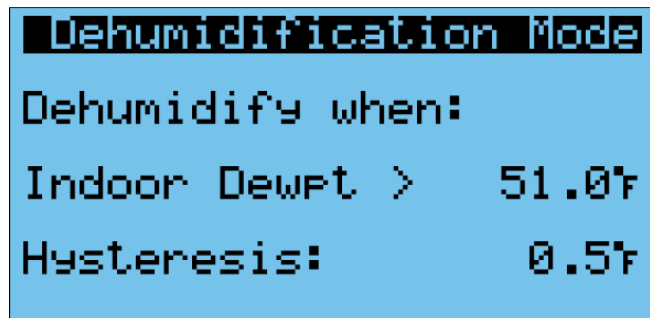

**Supply Dewpt Setpoint Screen.** Used to change the supply dew point set point, which can also be changed in the user settings menu. Only a qualified service technician should change this value.

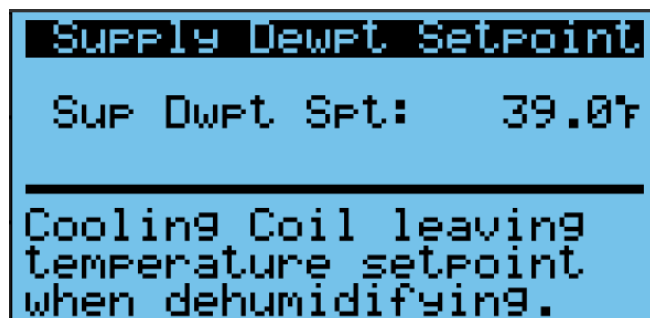



## MAJOR COMPONENTS

### Flat plate heat exchanger

Each DryComfort unit has a sensible heat transfer device called a flat plate heat exchanger . Each heat exchanger is a stack of thin aluminum plates that divide an airstream into many thin layers so that as much aluminum as possible can come in contact with the air . Warm air goes into the heat exchanger from one direction and that warm air rejects its heat energy to the aluminum so it can be collected by the cooler air on the other side of each aluminum plate . There is no user maintenance required for this heat exchanger .

#### Typical flat plate heat exchanger



Cool air is divided into many thin layers and passes through the heat exchanger at 90 °F to the other airstream. This cool air then accepts heat energy from the aluminum plates.

Warm, moist air is divided into many thin layers as it enters one side. Heat energy from the air is rejected to the aluminum plates.

### Refrigeration circuit

There is a complete refrigeration circuit inside each DryComfort unit, including a Digital Scroll™ compressor, an evaporator coil, a condensing coil, and all the required controls and sensors . The Digital Scroll™ compressor is capable of modulating capacity to match the dehumidification load . The result is a continuous output from the circuit, instead of frequently starting and stopping . Any servicing of the refrigeration circuit must be done by a qualified HVAC technician .

## Controls section

Each unit has a recessed control panel where all the electronics, such as the controller and the phase monitor, are located . On the door to the control panel, located on the outside of the unit, are the service switch, indicator lights, and main disconnect switch handle .

#### Controls section

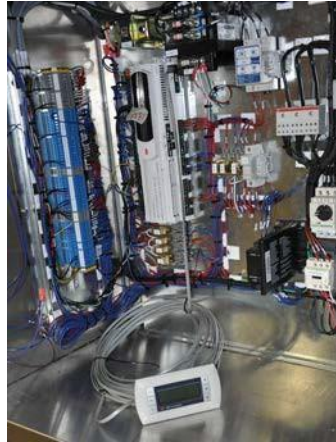

### Controller and keypad/display

Each DryComfort unit is controlled by an electronic controller . Once power is applied to the unit and the service switch is turned to AUTO, the controller operates the unit to maintain room dew point set point . It monitors inputs that are wired directly to it and then determines the most efficient means of reaching the moisture level set point . The controller is essentially a computer with a keypad/display . Everything that the controller is sensing and controlling can be viewed on the keypad/display . The settings on the controller will normally not need to be changed, but can be changed using the keypad/display.

#### Controller and keypad/display



## Phase monitor

Each unit has a phase monitor that constantly monitors all three phases of incoming electric power. If the monitor detects a variation in voltage or a loss of a phase, it will cause the unit to go into an alarm condition and send a signal to the controller. Once the alarm condition is corrected, the phase monitor will reset itself.

### Typical phase monitor



## Indicator lights

There are two indicator lights on the face of the control panel: one green light and one red light. The green light indicates that the unit has power and is operating properly. The red light is an alarm light that turns on whenever the unit controller detects a fault in the system. The lights should be viewed frequently to verify the unit is operating correctly.

### Indicator lights



The **Alarm Light** indicates the controller has detected an alarm condition. View the keypad/display to determine alarm source.

The **Unit ON Light** indicates that the unit has power and the Service Switch is ON.

The **Service Switch** is shown here in the OFF position. Turn clockwise 1/4 turn to switch to AUTO.

## Humidity/temperature sensor

Each unit has a humidity and temperature sensor installed in the process inlet air stream (inside the unit) that provides constant information to the controller.

### Typical temperature/humidity sensor



## Service switch

On the face of the control panel, there is a service switch. It's a simple rotary HAND/OFF/AUTO switch that is the primary means of shutting off the DryComfort unit.

## Fans

There is one premium-efficiency supply fan with an EC motor in each DryComfort unit. This fan is variable-speed and has a speed regulator built into it. The fan speed is controlled by a signal from the controller. The fan is permanently lubricated and requires no periodic maintenance outside of annual service by an HVAC technician.

### Typical fan



## MAINTENANCE

The only user-serviceable part of this unit is the air intake filter . As a general rule, change this filter every three months .

**IMPORTANT:** Dirty air filters will reduce unit operating efficiency .

**Note:** Air quality conditions change constantly, dependent on a number of factors . If a lot of dust is generated periodically in the room, the filter will need to be replaced more often .

## REPLACEMENT PARTS

The only replacement parts that an owner needs to be concerned with are the air intake filters . Replacement filters can be ordered from Q4 or obtained locally . Select replacement filters by size and MERV rating . Factory-recommended filters are 18" x 25" x 2" thick, pleated MERV 8 . When installing replacement filters, check to make sure the filter is seated properly and that there are no air leaks around the filter .

## TROUBLESHOOTING

During normal operation of this unit, the green indicator light on the front of the control panel will be lit (ON) and the red light will be OFF .

**Table 2: Troubleshooting guide**

SYMPTOM	CAUSE	ACTION
Green light is not lit.	There is no power getting to the controller.	<ol style="list-style-type: none"> <li>1. Make sure the service switch is turned AUTO or HAND.</li> <li>2. Make sure the main disconnect switch is turned ON.</li> <li>3. Check the circuit breakers that provide power to the unit.</li> </ol>
Green light and red light are both lit.	The controller has discovered a fault.	<ol style="list-style-type: none"> <li>1. Check the keypad/display to find the source of the alarm condition. Push the Alarm button on the keypad/display to see the alarm.</li> <li>2. If a red alarm light stays on for more than 30 minutes, turn the service switch to the OFF position and wait for 30 minutes and then turn the service switch back to ON.</li> <li>3. If the controller remains in alarm after restarting the unit, contact Q4 and tell them the alarm condition that shows on the keypad/display.</li> </ol>
Green light and red light are both lit and the unit continues to run.	The controller has discovered an alarm condition and is attempting to reset itself.	<ol style="list-style-type: none"> <li>1. If a red alarm light stays on for more than 30 minutes, turn the service switch to the OFF position and wait for 30 minutes, and then turn the service switch back to ON.</li> </ol>
Green light and red light are both lit and the unit does not run.	Loss of one or more phases in the power supply circuit.	<ol style="list-style-type: none"> <li>1. Check the circuit breakers that provide power to the unit.</li> <li>2. Check the fuses in the control panel.</li> </ol>
Strange noise: sounds like the compressor is trying to start but can't.	This is the normal sound of a digital scroll compressor modulating the capacity to meet the needs of the space.	No action required.

## WARRANTY

LIMITED WARRANTY AND DISCLAIMER: Seller warrants that at the time of delivery and for a period of twelve (12) months from the initial startup (Start-Up), Products will be free from defects in material and manufacture provided that Products have been installed with proper Start-Up, maintained and operated under normal conditions for service in accordance with the instructions of Seller, and that the Products have the capacities and ratings set forth in Seller's design specifications. Equipment Start-Up is defined as a complete test of the mechanical and electrical systems to confirm that the equipment is installed and operating per factory requirements. No warranty is made against corrosion, erosion or deterioration. At Seller's option, Seller's obligations and liabilities under this warranty are limited to repair of Products or replacement of components for Products not conforming to this warranty . Limited Warranty does not cover labor for component replacement . Once Seller's service department has been notified and approved any warranty related service work, Seller will repair or replace components as needed and ship FOB factory . Seller shall not be obligated to pay for the cost of lost refrigerant . Consumable parts and Products that are consumable in nature are explicitly excluded from this warranty . Consumables include, but are not limited to, belts, filters and refrigerant . No warranty or liability whatsoever shall attach to Seller until payment has been received . No warranty herein extended shall apply to correction of conditions arising from improper or incorrectly connected air duct, piping, wiring, power supply, blown fuses, freezing, improper Product control when programmed by non-Seller controls, or personnel, or by anyone other than Seller employee or its representative . Operation of Products for temporary conditioning of a building during construction without the written consent of an officer of the Seller immediately voids any warranty coverage . If the Product is replaced, the replacement may not be new, but will be in good working order and at least functionally equivalent to the item or Product being replaced . The replacement assumes the warranty status of the replaced product . The warranty period does not start over.

THIS LIMITED WARRANTY IS IMMEDIATELY VOIDED AND CANCELED BY ANY MISUSE, NEGLIGENCE, FAILURE TO FOLLOW INSTRUCTIONS OR MANUALS OF INSTALLATION OR MAINTENANCE, REPAIR, SERVICE, RELOCATION OR ALTERATION TO OR OF, OR OTHER TAMPERING WITH, THE PRODUCTS PERFORMED BY ANY PERSON OR ENTITY OTHER THAN SELLER WITHOUT SELLER'S PRIOR WRITTEN APPROVAL OR ANY USE OF REPLACEMENT PARTS NOT SUPPLIED BY SELLER WITH RESPECT TO THE AFFECTED PRODUCTS . BACK CHARGES RESULTING FROM CLAIMS UNDER THE WARRANTY SHALL BE RECOGNIZED ONLY WHEN PREVIOUSLY AUTHORIZED IN WRITING BY THE SELLER . THE WARRANTY AND LIABILITY SET FORTH HEREIN ARE IN LIEU OF ALL OTHER WARRANTIES AND LIABILITIES WHETHER IN CONTRACT, TORT, OR IN NEGLIGENCE, EXPRESSED OR IMPLIED, IN LAW OR IN FACT. INCLUDING IMPLIED WARRANTIES OF MERCHANTABILITY AND FITNESS FOR A PARTICULAR USE. SELLER PROVIDES NO INDEPENDENT WARRANTY FOR THIRD PARTY PRODUCTS OR COMPONENTS SOLD TOGETHER OR INCORPORATED WITH SELLER'S PRODUCT(S).

LIABILITY DISCLAIMER: TO THE MAXIMUM EXTENT PERMITTED BY LAW, SELLER'S TOTAL LIABILITY FOR CLAIMS, REGARDLESS OF THE FORM OF ACTION OR THEORY OF LIABILITY (INCLUDING CONTRACT, TORT OR WARRANTY), SHALL BE LIMITED TO THE FEES PAID TO SELLER BY BUYER FOR THE PRODUCTS OR LABOR ALLEGED TO CAUSE THE DAMAGE. IN NO EVENT SHALL SELLER BE LIABLE TO BUYER FOR ANY INCIDENTAL, CONSEQUENTIAL, SPECIAL, PUNITIVE, OR INDIRECT DAMAGES OF ANY KIND (INCLUDING WITHOUT LIMITATION, LOST PROFITS, LOSS OF USE, OR CLAIMS OF THIRD PARTIES) THAT MIGHT OCCUR AS A RESULT OF THE PERFORMANCE OR BREACH OF THE AGREEMENT OR IN ANY WAY ARISING OUT OF OR IN CONNECTION WITH THE AGREEMENT.

## CONTACT US / MORE INFORMATION

### Contact us

#### DryComfort Technical Support and Service

Phone: 614-392-0741

#### DryComfort Dehumidification Solutions/Q4 Energy Solutions

214 Hoff Road, Suite H  
Westerville, Ohio 43082

Main: 614-392-0741

### More information

#### Unit schematics

For configuration and connection questions, see the schematics that shipped with your unit . They can typically be found attached to the main control panel door .



© 2021 Q4 Energy Solutions, Inc .  
Continuous product improvement is a policy of Q4  
Energy Solutions, Inc; therefore, product functionality  
and specifications are subject to change without notice.

DryComfort Dehumidification Unit  
Owner's Manual  
Part number: 1016954  
Rev . 1 .1 .01  
November 9, 2018