

Air-Conditioners For Building Application

2014

TECHNICAL & SERVICE MANUAL

Series PFFY Floor Standing Type

<Indoor unit>

Models **PFFY-P06NRMU-E, PFFY-P08NRMU-E**
PFFY-P12NRMU-E, PFFY-P15NRMU-E
PFFY-P18NRMU-E, PFFY-P24NRMU-E
PFFY-P06NEMU-E, PFFY-P08NEMU-E
PFFY-P12NEMU-E, PFFY-P15NEMU-E
PFFY-P18NEMU-E, PFFY-P24NEMU-E

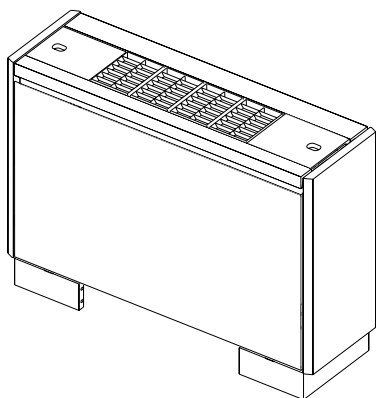

Exposed type

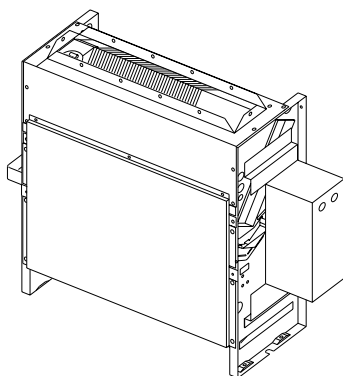

Concealed type

CONTENTS

SAFETY PRECAUTIONS	1
1. FEATURES	3
2. PART NAMES AND FUNCTIONS	4
3. SPECIFICATION	6
4. OUTLINES AND DIMENSIONS	8
5. WIRING DIAGRAM	10
6. REFRIGERANT SYSTEM DIAGRAM	11
7. TROUBLE SHOOTING	12
8. DISASSEMBLY PROCEDURE	17

CITY MULTI

For use with the R410A & R22

SAFETY PRECAUTIONS

1. Before installation and electric work

- ▶ Before installing the unit, make sure you read all the “Safety precautions”.
- ▶ The “Safety precautions” provide very important points regarding safety. Make sure you follow them.
- ▶ This equipment may cause the adverse effect on the same supply system.
- ▶ Please report to or take consent by the supply authority before connection to the system.

Symbols used in the text

Warning:

Describes precautions that should be observed to prevent danger of injury or death to the user.

Caution:

Describes precautions that should be observed to prevent damage to the unit.

Symbols used in the illustrations



: Indicates an action that must be avoided.



: Indicates that important instructions must be followed.



: Indicates a part which must be grounded.



: Indicates that caution should be taken with rotating parts. (This symbol is displayed on the main unit label.) <Color: Yellow>



: Beware of electric shock (This symbol is displayed on the main unit label.) <Color: Yellow>

Warning:

Carefully read the labels affixed to the main unit.

Warning:

- **Ask the dealer or an authorized technician to install the air conditioner.**
 - Improper installation by the user may result in water leakage, electric shock, or fire.
- **Install the air unit at a place that can withstand its weight.**
 - Inadequate strength may cause the unit to fall down, resulting in injuries.
- **Use the specified cables for wiring. Make the connections securely so that the outside force of the cable is not applied to the terminals.**
 - Inadequate connection and fastening may generate heat and cause a fire.
- **Prepare for typhoons and other strong winds and earthquakes and install the unit at the specified place.**
 - Improper installation may cause the unit to topple and result in injury.
- **Always use an air cleaner, humidifier, electric heater, and other accessories specified by Mitsubishi Electric.**
 - Ask an authorized technician to install the accessories. Improper installation by the user may result in water leakage, electric shock, or fire.

- **Never repair the unit. If the air conditioner must be repaired, consult the dealer.**
 - If the unit is repaired improperly, water leakage, electric shock, or fire may result.
- **Do not touch the heat exchanger fins.**
 - Improper handling may result in injury.
- **If refrigerant gas leaks during installation work, ventilate the room.**
 - If the refrigerant gas comes into contact with a flame, poisonous gases will be released.
- **Install the air conditioner according to this manual.**
 - If the unit is installed improperly, water leakage, electric shock, or fire may result.
- **Have all electric work done by a licensed electrician according to “Electric Facility Engineering Standard” and “Interior Wire Regulations” and the instructions given in this manual and always use a special circuit.**
 - If the power source capacity is inadequate or electric work is performed improperly, electric shock and fire may result.
- **Keep the electric parts away from water (washing water etc.).**
 - It might result in electric shock, catching fire or smoke.
- **Securely install the cover of control box and the panel.**
 - If the cover and panel are not installed properly, dust or water may enter the outdoor unit and fire or electric shock may result.
- **When installing and moving the air conditioner to another site, do not charge the it with a refrigerant different from the refrigerant specified on the unit.**
 - If a different refrigerant or air is mixed with the original refrigerant, the refrigerant cycle may malfunction and the unit may be damaged.
- **If the air conditioner is installed in a small room, measures must be taken to prevent the refrigerant concentration from exceeding the safety limit even if the refrigerant should leak.**
 - Consult the dealer regarding the appropriate measures to prevent the safety limit from being exceeded. Should the refrigerant leak and cause the safety limit to be exceeded, hazards due to lack of oxygen in the room could result.
- **When moving and reinstalling the air conditioner, consult the dealer or an authorized technician.**
 - If the air conditioner is installed improperly, water leakage, electric shock, or fire may result.
- **After completing installation work, make sure that refrigerant gas is not leaking.**
 - If the refrigerant gas leaks and is exposed to a fan heater, stove, oven, or other heat source, it may generate noxious gases.
- **Do not reconstruct or change the settings of the protection devices.**
 - If the pressure switch, thermal switch, or other protection device is shorted and operated forcibly, or parts other than those specified by Mitsubishi Electric are used, fire or explosion may result.
- **To dispose of this product, consult your dealer.**
- **Do not use a leak detection additive.**

⚠ Warning:

- **Note the following when building a heater in the air conditioning system.**
 - Leave enough space between units for proper ventilation so that the indoor unit temperature does not exceed 40°C when windless.
 - Keep the heater clean, and take appropriate measures so that the indoor unit does not suck in the dust particles that accumulate on the heater.
 - Use the optional heater cable (PAC-YU24HT) to perform an interlocked operation with indoor units.
 - Do not build a heater inside the indoor unit.

Recommended circuit

Wiring diagram

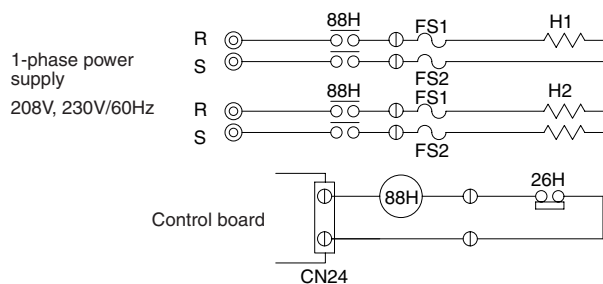

- FS1, 2 ----- Thermal fuse
- H1, H2 ----- Heater
- 26H ----- Overheat protection thermostat
- 88H ----- Electromagnetic contactor

2. Precautions for devices that use R410A refrigerant

⚠ Caution:

- **Do not use the existing refrigerant piping.**
 - The old refrigerant and refrigerator oil in the existing piping contains a large amount of chlorine which may cause the refrigerator oil of the new unit to deteriorate.
 - **Use refrigerant piping made of C1220 (Cu-DHP) phosphorus deoxidized copper as specified in the *JIS H3300 "Copper and copper alloy seamless pipes and tubes". In addition, be sure that the inner and outer surfaces of the pipes are clean and free of hazardous sulphur, oxides, dust/dirt, shaving particles, oils, moisture, or any other contaminant.**
 - Contaminants on the inside of the refrigerant piping may cause the refrigerant residual oil to deteriorate.
- *JIS: Japanese Industrial Standard
- **Store the piping to be used during installation indoors and keep both ends of the piping sealed until just before brazing. (Store elbows and other joints in a plastic bag.)**
 - If dust, dirt, or water enters the refrigerant cycle, deterioration of the oil and compressor trouble may result.
 - **Use ester oil, ether oil or alkylbenzene (small amount) as the refrigerator oil to coat flares and flange connections.**
 - The refrigerator oil will degrade if it is mixed with a large amount of mineral oil.
 - **Use liquid refrigerant to fill the system.**
 - If gas refrigerant is used to seal the system, the composition of the refrigerant in the cylinder will change and performance may drop.
 - **Do not use a refrigerant other than R410A.**
 - If another refrigerant (R22, etc.) is used, the chlorine in the refrigerant may cause the refrigerator oil to deteriorate.
 - **Use a vacuum pump with a reverse flow check valve.**
 - The vacuum pump oil may flow back into the refrigerant cycle and cause the refrigerator oil to deteriorate.
 - **Do not use the following tools that are used with conventional refrigerants. (Gauge manifold, charge hose, gas leak detector, reverse flow check valve, refrigerant charge base, vacuum gauge, refrigerant recovery equipment)**
 - If the conventional refrigerant and refrigerator oil are mixed in the R410A, the refrigerant may deteriorate.
 - If water is mixed in the R410A, the refrigerator oil may deteriorate.
 - Since R410A does not contain any chlorine, gas leak detectors for conventional refrigerants will not react to it.
 - **Do not use a charging cylinder.**
 - Using a charging cylinder may cause the refrigerant to deteriorate.
 - **Be especially careful when managing the tools.**
 - If dust, dirt, or water gets in the refrigerant cycle, the refrigerant may deteriorate.

Series PFFY Floor Standing Type

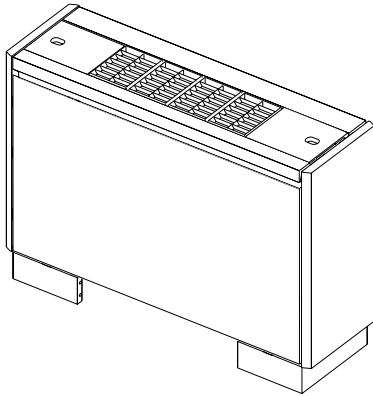

Exposed type

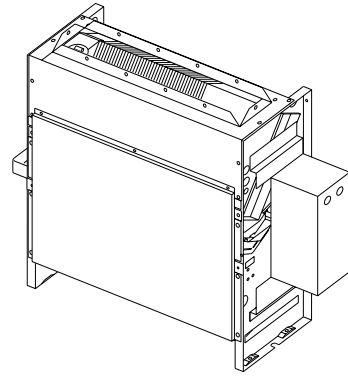

Concealed type

Models	Cooling capacity/Heating capacity	
	kW	BTU / h
PFFY-P06NEMU-E,PFFY-P06NRMU-E	1.8 / 2.0	6000 / 6700
PFFY-P08NEMU-E,PFFY-P08NRMU-E	2.3 / 2.6	8000 / 9000
PFFY-P12NEMU-E,PFFY-P12NRMU-E	3.5 / 4.0	12000 / 13500
PFFY-P15NEMU-E,PFFY-P15NRMU-E	4.4 / 5.0	15000 / 17000
PFFY-P18NEMU-E,PFFY-P18NRMU-E	5.3 / 5.9	18000 / 20000
PFFY-P24NEMU-E,PFFY-P24NRMU-E	7.0 / 7.9	24000 / 27000

2

PART NAMES AND FUNCTIONS

● Indoor (Main) Unit

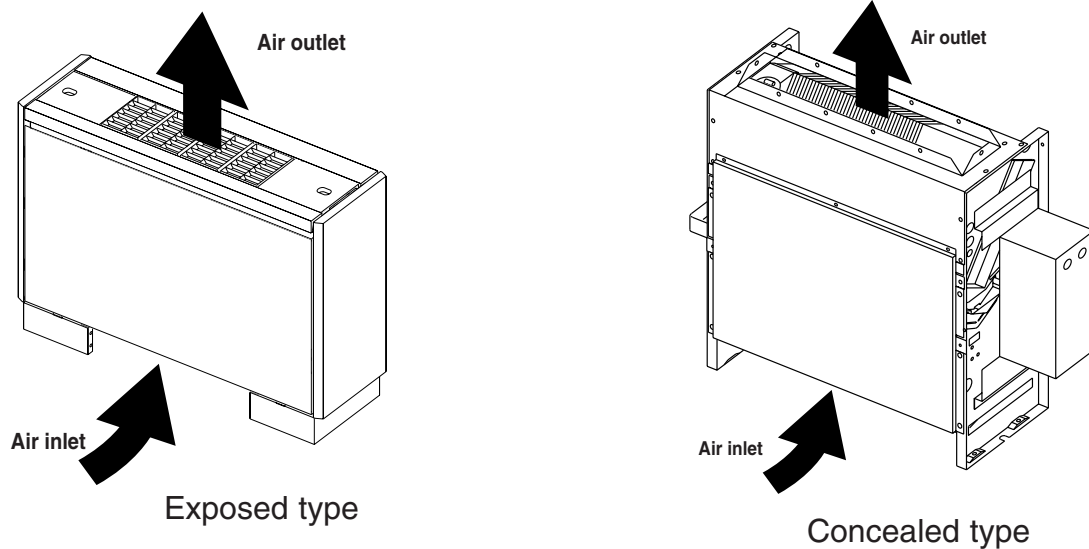

● Remote controller

[PAR-21MAA]

- Once the controls are set, the same operation mode can be repeated by simply pressing the ON/OFF button.

[Operation buttons]

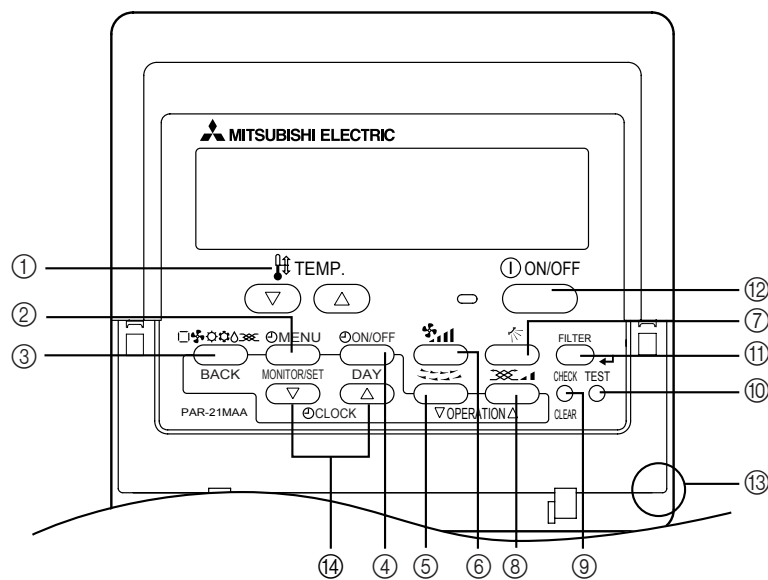

- | | | |
|----------------------------|----------------------------|---|
| ① [Set Temperature] Button | ⑤ [Louver] Button | ⑩ [Test run] Button |
| ② [Timer Menu] Button | [Operation] Button | ⑪ [Filter] Button |
| [Monitor/Set] Button | ⑥ [Fan Speed] Button | [↵] Button |
| ③ [Mode] Button | ⑦ [Airflow Up/Down] Button | ⑫ [ON/OFF] Button |
| [Return] Button | ⑧ [Ventilation] Button | ⑬ Position of built-in room temperature |
| ④ [Timer On/Off] Button | [Operation] Button | ⑭ [Set Time] Button |
| [Set Day] Button | ⑨ [Check/Clear] Button | |

- Never expose the remote controller to direct sunlight. Doing so can result in the erroneous measurement of room temperature.
- Never place any obstacle around the lower right-hand section of the remote controller. Doing so can result in the erroneous measurement of room temperature.

[Display]

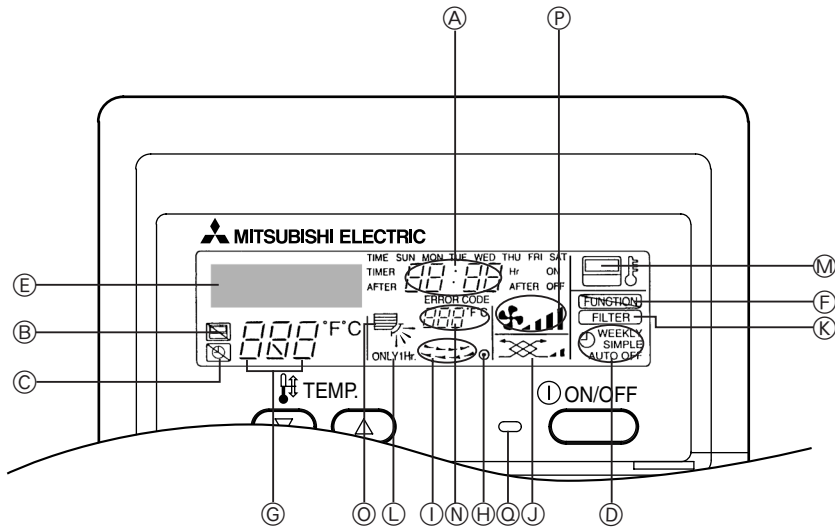

- Ⓐ Current time/Timer
- Ⓑ Centralized control
- Ⓒ Timer OFF
- Ⓓ Timer indicator
- Ⓔ Operation mode: ❄️ COOL, 💧 DRY, 🏠 AUTO, 🌀 FAN, 🔥 HEAT
- Ⓕ "Locked" indicator
- Ⓖ Set temperature
- Ⓗ Power ON
- Ⓘ Louver
- Ⓙ Ventilation
- Ⓚ Filter sign
- Ⓛ Set effective for 1 hr.
- Ⓜ Sensor position
- Ⓝ Room temperature
- Ⓞ Airflow
- Ⓟ Fan speed

3

SPECIFICATION

3-1. Specification

PFFY-P-NEMU-E

Item		Model	PFFY-P06NEMU-E	PFFY-P08NEMU-E	PFFY-P12NEMU-E	PFFY-P15NEMU-E	PFFY-P18NEMU-E	PFFY-P24NEMU-E
Power source			208/230V, 60Hz					
Capacity *1	Cooling	kW	1.8	2.3	3.5	4.4	5.3	7.0
		BTU/h	6000	8000	12000	15000	18000	24000
	Heating	kW	2.0	2.6	4.0	5.0	5.9	7.9
		BTU/h	6700	9000	13500	17000	20000	27000
Dimension	Height	mm	630					
		in	24-13/16					
	Width	mm	1050		1170		1410	
		in	41-11/32		46-3/32		55-17/32	
Depth	mm	220						
	in	8-11/16						
Net weight	kg	23	23	25	26	30	32	
	lb	51	51	56	58	67	71	
FAN	Airflow rate (Low-High)	m ³ /min	5.5-6.5	5.5-6.5	7.0-9.0	8.5-11.0	10.0-13.0	10.0-14.0
		cfm	194-229	194-229	247-317	300-388	353-459	353-494
	External static pressure	Pa	208V	-	-	-	-	-
230V			-	-	-	-	-	-
Noise level (Low-High) *2	dB(A)	208V	36-41	36-41	37-41	38-43	38-43	40-46
		230V	36-41	36-41	37-41	38-43	38-43	40-46
Filter			Standard filter					

PFFY-P-NRMU-E

Item		Model	PFFY-P06NRMU-E	PFFY-P08NRMU-E	PFFY-P12NRMU-E	PFFY-P15NRMU-E	PFFY-P18NRMU-E	PFFY-P24NRMU-E
Power source			208/230V, 60Hz					
Capacity *1	Cooling	kW	1.8	2.3	3.5	4.4	5.3	7.0
		BTU/h	6000	8000	12000	15000	18000	24000
	Heating	kW	2.0	2.6	4.0	5.0	5.9	7.9
		BTU/h	6700	9000	13500	17000	20000	27000
Dimension	Height	mm	639					
		in	25-3/16					
	Width	mm	886		1006		1246	
		in	34-29/32		39-5/8		49-1/16	
Depth	mm	220						
	in	8-11/16						
Net weight	kg	19	19	20	21	25	27	
	lb	41	41	45	47	56	60	
FAN	Airflow rate (Low-High)	m ³ /min	5.5-6.5	5.5-6.5	7.0-9.0	8.5-11.0	10.0-13.0	10.0-14.0
		cfm	194-229	194-229	247-317	300-388	353-459	353-494
	External static pressure	Pa	208V	-	-	-	-	-
230V			-	-	-	-	-	-
Noise level (Low-High) *2	dB(A)	208V	36-41	36-41	37-41	38-43	38-43	40-46
		230V	36-41	36-41	37-41	38-43	38-43	40-46
Filter			Standard filter					

Notes: *1 Cooling/Heating capacity indicates the maximum value at operation under the following condition.

Cooling: Indoor: 26.7 °C [80 °F] DB/19.4 °C [67 °F] WB Outdoor: 35 °C [95 °F] DB

Heating: Indoor: 21.1 °C [70 °F] DB Outdoor: 8.3 °C [47 °F] DB/6.1 °C [43 °F] WB

*2 The operating noise is the data that was obtained in an anechoic room.

3-2. Electrical parts specification

Parts name \ Model	Symbol	PFFY-P06 (NEMU-E NRMU-E)	PFFY-P08 (NEMU-E NRMU-E)	PFFY-P12 (NEMU-E NRMU-E)	PFFY-P15 (NEMU-E NRMU-E)	PFFY-P18 (NEMU-E NRMU-E)	PFFY-P24 (NEMU-E NRMU-E)
Transformer	T	(Primary) 60Hz 208-230V (Secondary) (23.5V 0.9A)					
Room temperature thermistor	TH21	Resistance 0°C[32°F]/15kΩ, 10°C[50°F]/9.6kΩ, 20°C[68°F]/6.3kΩ, 25°C[77°F]/5.4kΩ, 30°C[86°F]/4.3kΩ, 40°C[104°F]/3.0kΩ					
Liquid pipe thermistor	TH22	Resistance 0°C[32°F]/15kΩ, 10°C[50°F]/9.6kΩ, 20°C[68°F]/6.3kΩ, 25°C[77°F]/5.4kΩ, 30°C[86°F]/4.3kΩ, 40°C[104°F]/3.0kΩ					
Gas pipe thermistor	TH23	Resistance 0°C[32°F]/15kΩ, 10°C[50°F]/9.6kΩ, 20°C[68°F]/6.3kΩ, 25°C[77°F]/5.4kΩ, 30°C[86°F]/4.3kΩ, 40°C[104°F]/3.0kΩ					
Fuse (Indoor controller board)	FUSE	250V 6.3A					
Fan motor (with Inner-thermostat)	MF1,2	4-pole OUTPUT 15W CU-0206B-A	4-pole OUTPUT 15W CU-0206B-A	4-pole OUTPUT 18W CU-0207B-A	4-pole OUTPUT 30W CU-0303B-A	4-pole OUTPUT 35W CRC4415AB	4-pole OUTPUT 50W CU-0507B-A
Inner-thermostat/ thermal fuse (Fan motor)		OFF 130°C±5°C [266°F±41°F] ON 90°C±20°C [194°F±68°F]					FUSE 152°C ⁺⁵ / ₀ °C [306°F ⁺⁴¹ / ₊₃₂ °F] CUT OFF
Fan motor capacitor	C1	1.5μF X 440V				2.0μF X 440V	2.5μF X 440V
Linear expansion valve	LEV	DC12V Stepping motor drive port dimension ø3.2 (0~2000pulse)					
Power supply terminal bed	TB2	(L1, L2, G) 330V 30A					
Transmission terminal bed	TB5 TB15	(1,2),(M1,M2,S) 300V 10A					

4

OUTLINES AND DIMENSIONS

PFFY-P06-08-12-15-18-24NEMU-E

Unit:mm(in.)

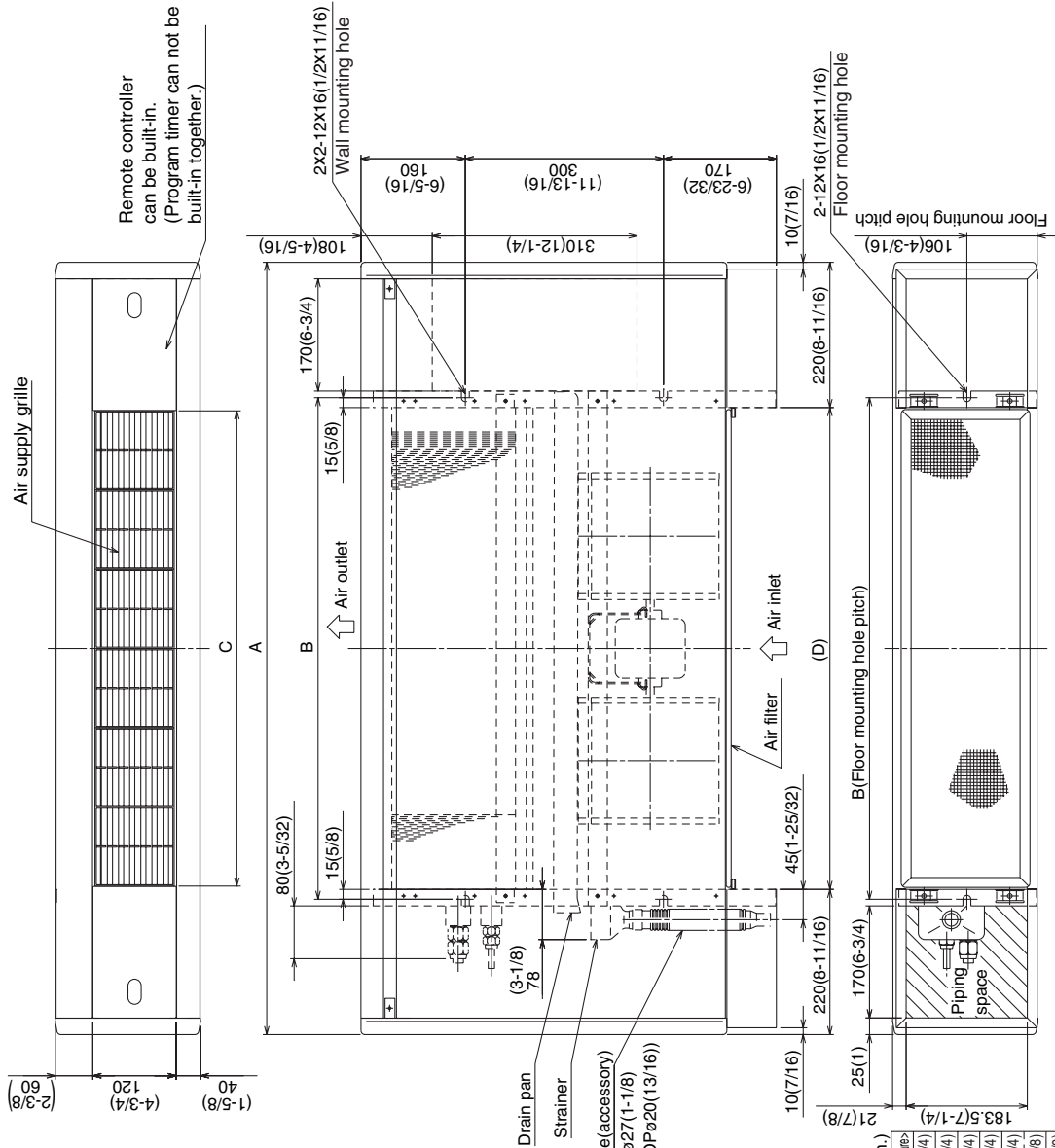

※ On Model :18, you would use flare nut packed with the Indoor Unit, when connecting the Outdoor Unit for R22.

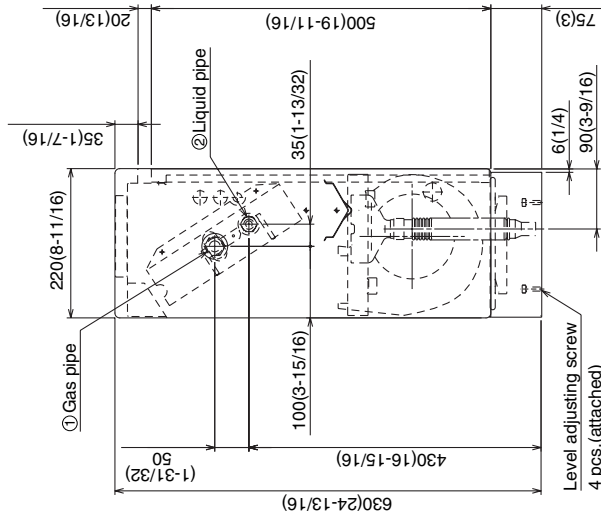

Model	A	B	C	D	① Gas pipe<flare>	② Liquid pipe<flare>
PFFY-P06NEMU-E	1050(41-11/32)	640(25-7/32)	600(23-5/8)	610(24-1/16)	ø12.7(1/2)	ø6.35(1/4)
PFFY-P08NEMU-E	1050(41-11/32)	640(25-7/32)	600(23-5/8)	610(24-1/16)	ø12.7(1/2)	ø6.35(1/4)
PFFY-P12NEMU-E	1170(46-1/16)	760(29-15/16)	720(28-3/8)	730(28-3/4)	ø12.7(1/2)	ø6.35(1/4)
PFFY-P15NEMU-E	1170(46-1/16)	760(29-15/16)	720(28-3/8)	730(28-3/4)	ø12.7(1/2)	ø6.35(1/4)
PFFY-P18NEMU-E	1400(55-17/32)	1000(39-3/8)	960(37-13/16)	970(38-1/4)	※1 ø12.7(1/2) ※2 ø15.88(5/8)	※1 ø6.35(1/4) ※2 ø9.52(3/8)
PFFY-P24NEMU-E	1400(55-17/32)	1000(39-3/8)	960(37-13/16)	970(38-1/4)	ø15.88(5/8)	ø9.52(3/8)

※1 :R410A outdoor unit

※2 :R22 outdoor unit

PFFY-P06-08-12-15-18-24NRMU-E

Unit:mm(in.)

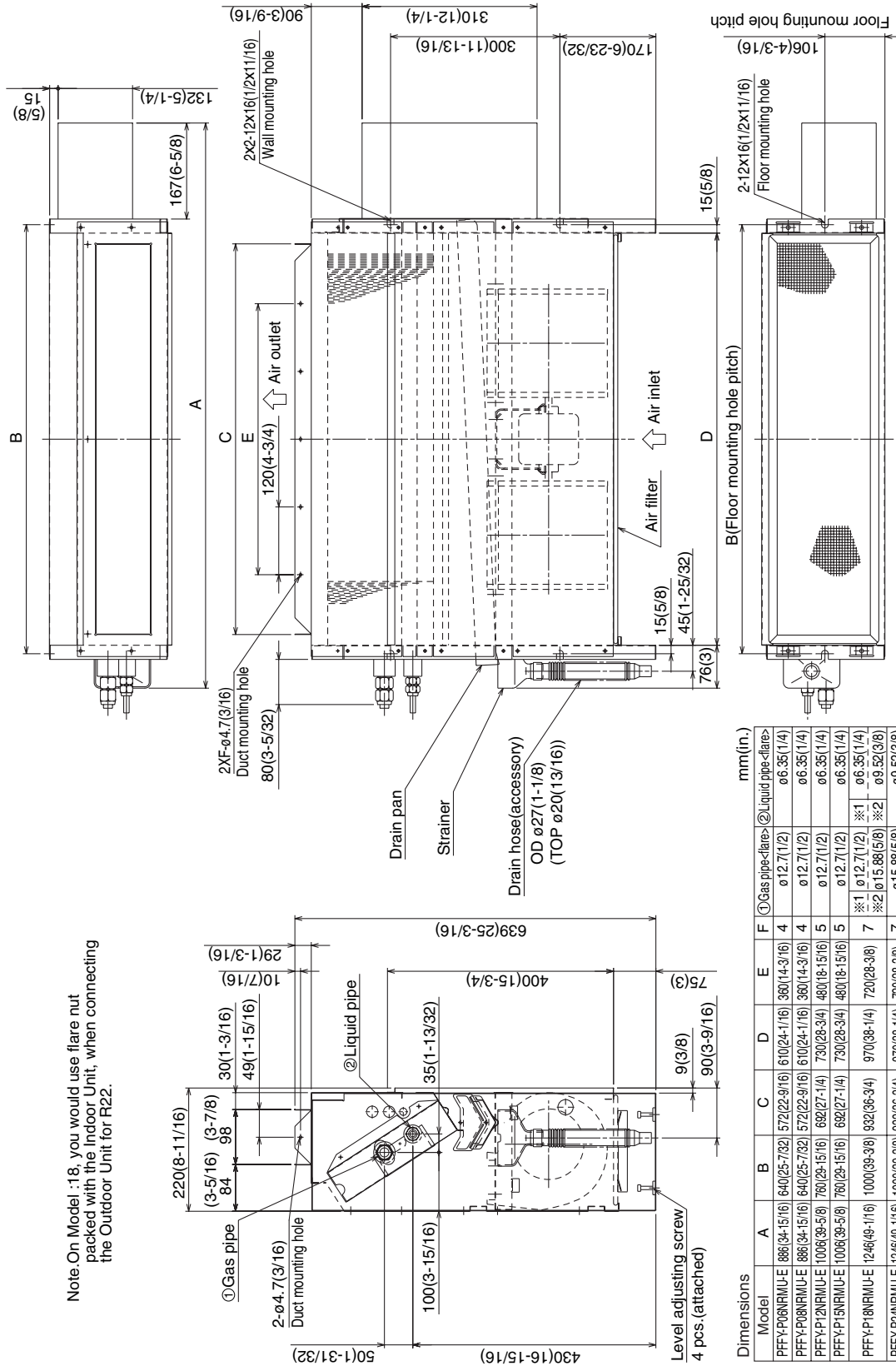

Note: On Model :18, you would use flare nut packed with the Indoor Unit, when connecting the Outdoor Unit for R22.

※1 :R410A outdoor unit
 ※2 :R22 outdoor unit

PFFY-P06-08-12-15-18-24NRMU(NEMU)-E

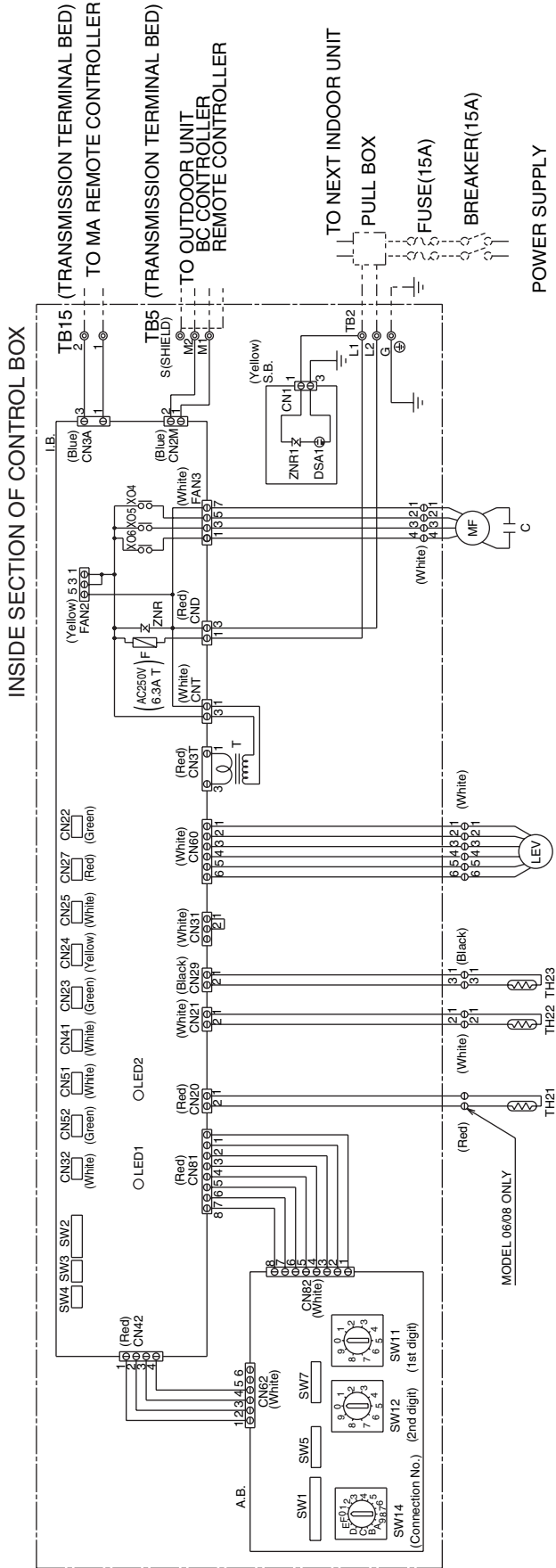

POWER SUPPLY
~208/230V 60Hz

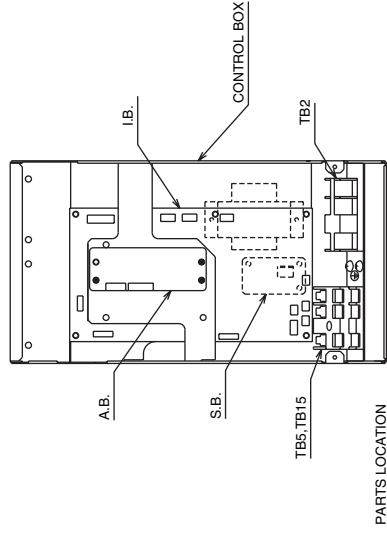

PARTS LOCATION

NOTE:1. The wirings to TB2, TB5, TB15 shown in chained line are field work.
2. Mark ⊙ indicates terminal bed, ⊕ connector, ⊞ board insertion connector or fastening connector of control board.

SYMBOL EXPLANATION

SYMBOL	NAME	SYMBOL	NAME	SYMBOL	NAME
MF	Fan motor	LED1	Power supply (I.B.)	TH21	Thermistor (inlet temp. detection)
C	Capacitor (for MF)	LED2	Power supply (Remote controller)	TH22	Thermistor (piping temp. detection/liquid)
I.B.	Indoor controller board	CN22	Connector	TH23	Thermistor (piping temp. detection/gas)
A.B.	Address board	CN23	Connector	SW11(A.B.)	Switch (1st digit address set)
TB2	Power source terminal bed	CN24	Connector	SW12(A.B.)	Switch (2nd digit address set)
TB5	Transmission terminal bed	CN25	Connector	SW14(A.B.)	Switch (connection No. set)
TB15	Transmission terminal bed	CN27	Connector	SW1(A.B.)	Switch(for mode selection)
F	Fuse AC250V 6.3A T	CN32	Connector (Centrally control)	SW5(A.B.)	Switch(for voltage selection)
T	Transformer	CN41	Connector (HA terminal-A)	SW7(A.B.)	Switch(for model selection)
LEV	Electronic linear expans. valve	CN51	Connector (Centrally control)	SW2(L.B.)	Switch(for capacity code)
S.B.	Surge absorber board	CN52	Connector (Remote indication)	SW3(L.B.)	Switch(for mode selection)
X04-06	Aux. relay	ZNR, ZNR1	Varistor	SW4(L.B.)	Switch(for model selection)

6

REFRIGERANT SYSTEM DIAGRAM

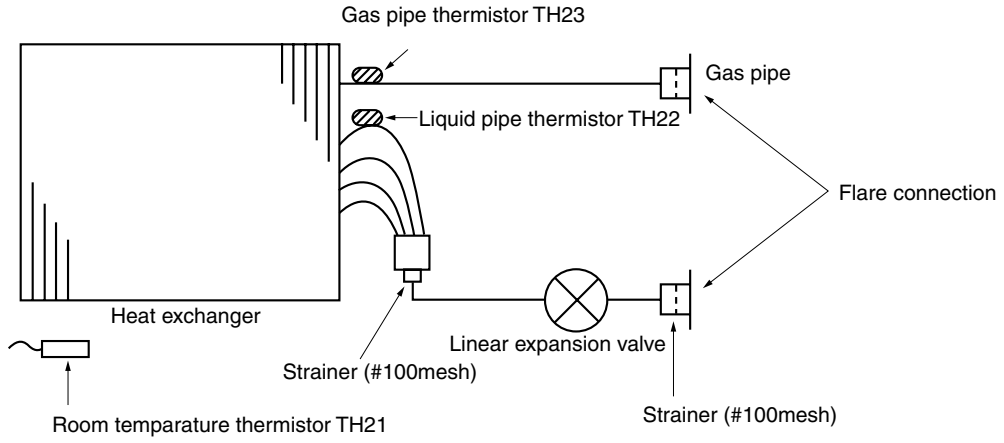

mm <in.>

Item	Capacity	PEFY-P06,08,12,15NEMU-E	PEFY-P18NEMU-E	PEFY-P24NEMU-E
		PEFY-P06,08,12,15NRMU-E	PEFY-P18NRMU-E	PEFY-P24NRMU-E
Gas pipe	R410A	Ø 12.7(1/2)		Ø 15.88(5/8)
	R22	Ø 12.7(1/2)	Ø 15.88(5/8)	Ø 15.88(5/8)
Liquid pipe	R410A	Ø 6.35(1/4)		Ø 9.52(3/8)
	R22	Ø 6.35(1/4)	Ø 9.52(3/8)	Ø 9.52(3/8)

7

TROUBLE SHOOTING

7-1. How to check the parts

Parts name	Check points																															
Room temperature thermistor (TH21) Liquid pipe thermistor (TH22) Gas pipe thermistor (TH23)	Disconnect the connector, then measure the resistance using a tester. (Surrounding temperature 10°C~30°C[50°F~86°F]) <table border="1" style="margin-left: 20px;"> <thead> <tr> <th>Normal</th> <th>Abnormal</th> </tr> </thead> <tbody> <tr> <td>4.3kΩ~9.6kΩ</td> <td>Open or short</td> </tr> </tbody> </table> (Refer to the thermistor characteristic graph on next page.)	Normal	Abnormal	4.3kΩ~9.6kΩ	Open or short																											
Normal	Abnormal																															
4.3kΩ~9.6kΩ	Open or short																															
Transformer 	Disconnect the connector and measure the resistance using a tester. <table border="1" style="margin-left: 20px;"> <thead> <tr> <th></th> <th>Normal</th> <th>Abnormal</th> </tr> </thead> <tbody> <tr> <td>CNT(1)-(3)</td> <td>App.15Ω</td> <td rowspan="2">Open or short</td> </tr> <tr> <td>CN3T(1)-(3)</td> <td>App.4Ω</td> </tr> </tbody> </table>		Normal	Abnormal	CNT(1)-(3)	App.15Ω	Open or short	CN3T(1)-(3)	App.4Ω																							
	Normal	Abnormal																														
CNT(1)-(3)	App.15Ω	Open or short																														
CN3T(1)-(3)	App.4Ω																															
Linear expansion valve 	Disconnect the connector then measure the resistance valve using a tester. Refer to the next page for a detail. <table border="1" style="margin-left: 20px;"> <thead> <tr> <th colspan="4">Normal</th> <th>Abnormal</th> </tr> </thead> <tbody> <tr> <td>(1)-(5) White-Red</td> <td>(2)-(6) Yellow-Blown</td> <td>(3)-(5) Orange-Red</td> <td>(4)-(6) Blue-Brown</td> <td rowspan="2">Open or short</td> </tr> <tr> <td colspan="4" style="text-align: center;">200Ω ±10%</td> </tr> </tbody> </table>	Normal				Abnormal	(1)-(5) White-Red	(2)-(6) Yellow-Blown	(3)-(5) Orange-Red	(4)-(6) Blue-Brown	Open or short	200Ω ±10%																				
Normal				Abnormal																												
(1)-(5) White-Red	(2)-(6) Yellow-Blown	(3)-(5) Orange-Red	(4)-(6) Blue-Brown	Open or short																												
200Ω ±10%																																
Fan motor PFFY-P06~18 NEMU-E/NRMU-E 	Measure the resistance between the terminals using a tester. (at 20°C[68°F]) <table border="1" style="margin-left: 20px;"> <thead> <tr> <th rowspan="2">Motor terminal or Relay connector</th> <th colspan="4">Normal</th> <th rowspan="2">Abnormal</th> </tr> <tr> <th>8,10</th> <th>12</th> <th>16</th> <th>20</th> </tr> </thead> <tbody> <tr> <td>Black - White</td> <td>335.0</td> <td>294.0</td> <td>114.0</td> <td>101.4</td> <td rowspan="5">Open or short</td> </tr> <tr> <td>Red - Yellow</td> <td>174.0</td> <td>150.0</td> <td>80.0</td> <td>60.3</td> </tr> <tr> <td>Yellow - Blue</td> <td>56.8</td> <td>52.0</td> <td>30.0</td> <td>15.1</td> </tr> <tr> <td>Blue - Black</td> <td>99.6</td> <td>78.0</td> <td>42.0</td> <td>29.4</td> </tr> </tbody> </table>	Motor terminal or Relay connector	Normal				Abnormal	8,10	12	16	20	Black - White	335.0	294.0	114.0	101.4	Open or short	Red - Yellow	174.0	150.0	80.0	60.3	Yellow - Blue	56.8	52.0	30.0	15.1	Blue - Black	99.6	78.0	42.0	29.4
Motor terminal or Relay connector	Normal				Abnormal																											
	8,10	12	16	20																												
Black - White	335.0	294.0	114.0	101.4	Open or short																											
Red - Yellow	174.0	150.0	80.0	60.3																												
Yellow - Blue	56.8	52.0	30.0	15.1																												
Blue - Black	99.6	78.0	42.0	29.4																												
Fan motor PFFY-P24 NEMU-E/NRMU-E 	Measure the resistance between the terminals using a tester. (at 20°C[68°F]) <table border="1" style="margin-left: 20px;"> <thead> <tr> <th rowspan="2">Motor terminal or Relay connector</th> <th>Normal</th> <th rowspan="2">Abnormal</th> </tr> <tr> <th>24</th> </tr> </thead> <tbody> <tr> <td>Black - White</td> <td>112.0</td> <td rowspan="5">Open or short</td> </tr> <tr> <td>Red - Yellow</td> <td>78.0</td> </tr> <tr> <td>Yellow - Blue</td> <td>12.7</td> </tr> <tr> <td>Blue - Black</td> <td>50.8</td> </tr> </tbody> </table>	Motor terminal or Relay connector	Normal	Abnormal		24	Black - White	112.0	Open or short	Red - Yellow	78.0	Yellow - Blue	12.7	Blue - Black	50.8																	
Motor terminal or Relay connector	Normal		Abnormal																													
	24																															
Black - White	112.0	Open or short																														
Red - Yellow	78.0																															
Yellow - Blue	12.7																															
Blue - Black	50.8																															

<Thermistor Characteristic graph>

Thermistor for lower temperature

- Room temperature thermistor(TH21)
- Liquid pipe thermistor(TH22)
- Gas pipe temperature thermistor(TH23)
- Drain sensor(DS)

Thermistor $R_0=15k\Omega \pm 3\%$
 Fixed number of $B=3480k\Omega \pm 2\%$

$$R_t=15 \exp \left\{ 3480 \left(\frac{1}{273+t} - \frac{1}{273} \right) \right\}$$

0°C	32°F	15kΩ
10°C	50°F	9.6kΩ
20°C	68°F	6.3kΩ
25°C	77°F	5.2kΩ
30°C	86°F	4.3kΩ
40°C	104°F	3.0kΩ

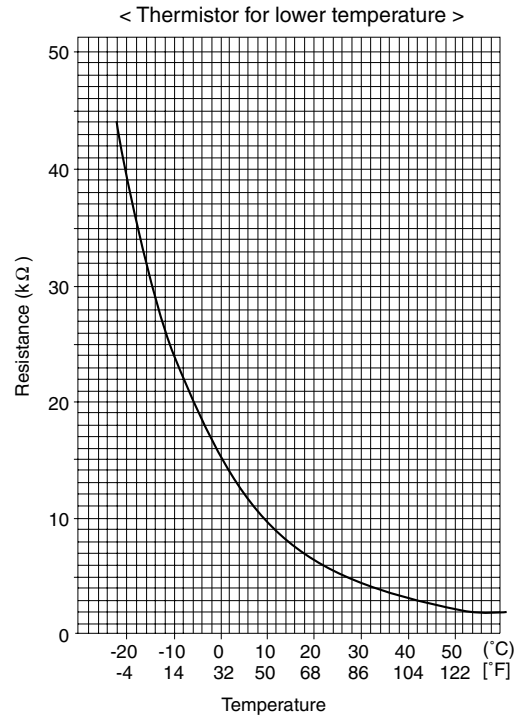

Linear expansion valve

① Operation summary of the linear expansion valve.

- Linear expansion valve open/close through stepping motor after receiving the pulse signal from the indoor controller board.
- Valve position can be changed in proportion to the number of pulse signal.

<Connection between the indoor controller board and the linear expansion valve>

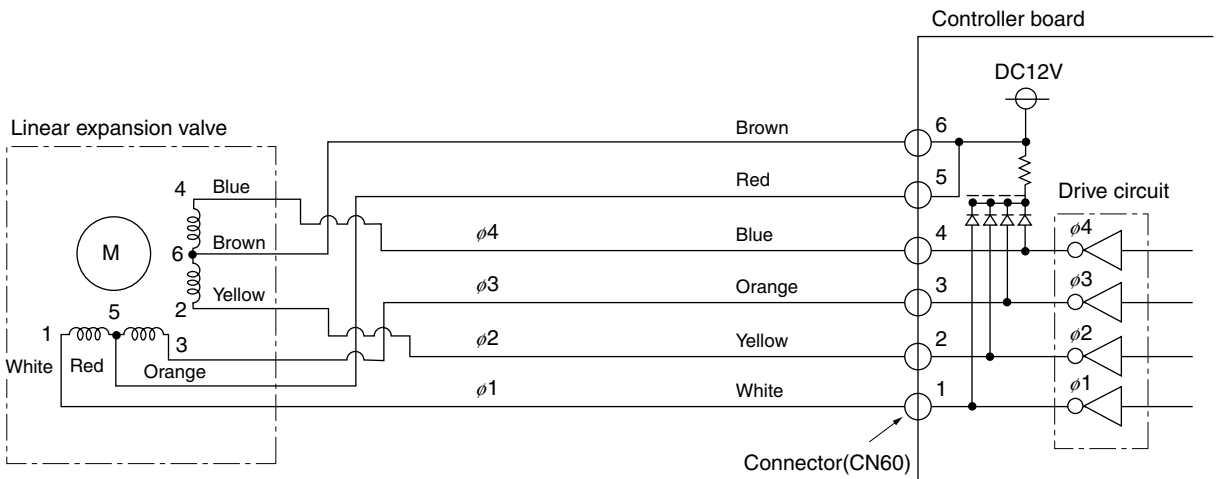

<Output pulse signal and the valve operation>

Output (Phase)	Output			
	1	2	3	4
φ1	ON	OFF	OFF	ON
φ2	ON	ON	OFF	OFF
φ3	OFF	ON	ON	OFF
φ4	OFF	OFF	ON	ON

Closing a valve : 1 → 2 → 3 → 4 → 1
 Opening a valve : 4 → 3 → 2 → 1 → 4

The output pulse shifts in above order.

- * 1. When linear expansion valve operation stops, all output phase become OFF.
- 2. At phase interruption or when phase does not shift in order, motor does not rotate smoothly and motor will locks and vibrates.

② Linear expansion valve operation

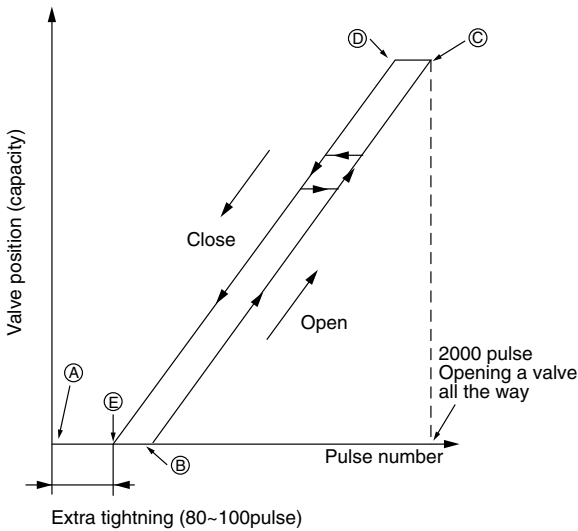

- * When the switch is turned on, 2200 pulse closing valve signal will be send till it goes to A point in order to define the valve position.

When the valve move smoothly, there is no noise or vibration occurring from the linear expansion valve : however, when the pulse number moves from E to A or when the valve is locked, more noise can be heard than normal situation.

- * Noise can be detected by placing the ear against the screw driver handle while putting the screw driver to the linear expansion valve.

③ Trouble shooting

Symptom	Check points	Countermeasures
Operation circuit failure of the micro processor.	Disconnect the connector on the controller board, then connect LED for checking. Pulse signal will be sent out for 10 seconds as soon as the main switch is turn on. If there is LED with lights on or lights off, it means the operation circuit is abnormal.	Exchange the indoor controller board at drive circuit failure.
Linear expansion valve mechanism is locked.	Motor will idle and make ticking noise when motor is operated while the linear expansion valve is locked. This ticking sound is the sign of the abnormality.	Exchange the linear expansion vale.
Short or breakage of the motor coil of the linear expansion valve.	Measure the resistance between the each coil (red-white, red-orange, brown-yellow, brown-blue) using a tester. It is normal if the resistance is in the range of $200\Omega \pm 10\%$.	Exchange the linear expansion valve.
Valve doesn't close completely (thermistor leaking).	To check the linear expansion valve, operate the indoor unit in fan mode and at the same time operate other indoor units in cooling mode, then check the pipe temperature <liquid pipe temperature> of the indoor unit by the outdoor multi controller board operation monitor. During fan operation, linear expansion valve is closed completely and if there are some leaking, detecting temperature of the thermistor will go lower. If the detected temperature is much lower than the temperature indicated in the remote controller, it means the valve is not closed all the way. It is not necessary to exchange the linear expansion valve, if the leakage is small and not making any trouble. 	If large amount of refrigeration is leaked, exchange the linear expansion valve.
Wrong connection of the connector or contact failure.	Check the color of lead wire and missing terminal of the connector.	Disconnect the connector at the controller board, then check the continuity.

7-2. Setting of address switch

Make sure that power source is turning off.

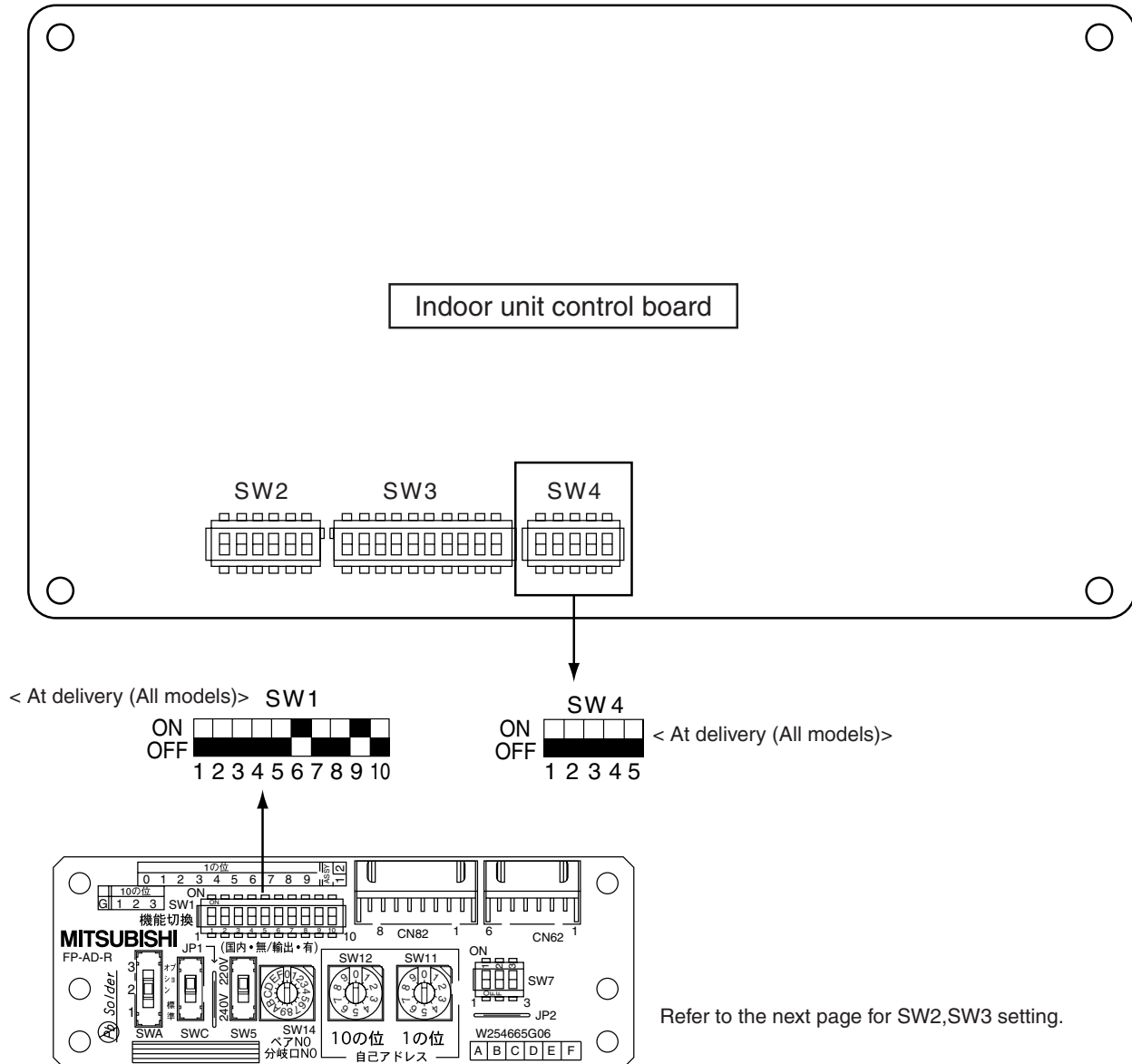

1) In case using M-NET remote controller, address is set by rotary switches.(SW11,SW12)

* It is not necessary setting address in case of using unit remote controller.

Indoor unit do not run without address setting in field.

2) Indoor unit address setting rule is different by each field work.













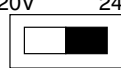
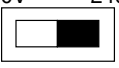









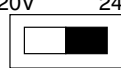
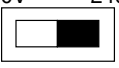







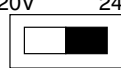
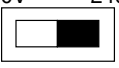

Refer to install manual of outdoor unit , operate the address setting.

3) Setting the address is combination of SW11(1st digit address setting) and SW12(2nd digit address setting).

Address " 3 " setting is composed SW11 " 3 " and SW12 " 0 " .

Address " 25 " setting is composed SW11 " 5 " and SW12 " 2 " .

7-3. Function of Dip-switch

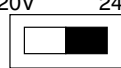
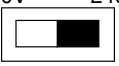
Switch	Pole	Function	Operation by switch		Remarks																														
			ON	OFF																															
SW1 Mode Selection	1	Thermistor<Intake temperature detection>position	Built-in remote controller	Indoor unit	<div style="border: 1px solid black; padding: 5px; text-align: center;">Address board</div> <At delivery> 																														
	2	Filter clogging detection	Provided	Not provided																															
	3	Filter life	2,500hr	100hr																															
	4	Air intake	Effective	Not effective																															
	5	Remote indication switching	Thermostat ON signal indication	Fan output indication																															
	6	Humidifier control	Always operated while the heat is ON	Operated depends on the condition																															
	7	Air flow st	Low	Extra low																															
	8	Heat thermostat OFF	Setting air flow	Reset to SW1-7																															
	9	Auto reset function	Effective	Not effective																															
	10	Power ON/OFF	Effective	Not effective																															
SW2 Capacity code setting	1~6	<table border="1" style="width: 100%; text-align: center;"> <tr> <th>MODELS</th> <th>SW2</th> <th>MODELS</th> <th>SW2</th> <th>MODELS</th> <th>SW2</th> </tr> <tr> <td>PFFY-P06NEMU-E</td> <td></td> <td>PFFY-P08NEMU-E</td> <td></td> <td>PFFY-P12NEMU-E</td> <td></td> </tr> <tr> <td>PFFY-P15NEMU-E</td> <td></td> <td>PFFY-P18NEMU-E</td> <td></td> <td>PFFY-P24NEMU-E</td> <td></td> </tr> <tr> <td>PFFY-P06NRMU-E</td> <td></td> <td>PFFY-P08NRMU-E</td> <td></td> <td>PFFY-P12NRMU-E</td> <td></td> </tr> <tr> <td>PFFY-P15NRMU-E</td> <td></td> <td>PFFY-P18NRMU-E</td> <td></td> <td>PFFY-P24NRMU-E</td> <td></td> </tr> </table>	MODELS	SW2	MODELS	SW2	MODELS	SW2	PFFY-P06NEMU-E		PFFY-P08NEMU-E		PFFY-P12NEMU-E		PFFY-P15NEMU-E		PFFY-P18NEMU-E		PFFY-P24NEMU-E		PFFY-P06NRMU-E		PFFY-P08NRMU-E		PFFY-P12NRMU-E		PFFY-P15NRMU-E		PFFY-P18NRMU-E		PFFY-P24NRMU-E				<div style="border: 1px solid black; padding: 5px; text-align: center;">Indoor controller board</div> Set while the unit is off. <At delivery> Set for each capacity.
		MODELS	SW2	MODELS	SW2	MODELS	SW2																												
		PFFY-P06NEMU-E		PFFY-P08NEMU-E		PFFY-P12NEMU-E																													
		PFFY-P15NEMU-E		PFFY-P18NEMU-E		PFFY-P24NEMU-E																													
PFFY-P06NRMU-E		PFFY-P08NRMU-E		PFFY-P12NRMU-E																															
PFFY-P15NRMU-E		PFFY-P18NRMU-E		PFFY-P24NRMU-E																															
SW3 Function Selection	1	Heat pump/Cool only	Cooling only	Heat pump	<div style="border: 1px solid black; padding: 5px; text-align: center;">Indoor controller board</div> Set while the unit is off. <At delivery>  (Note:1) At cooling mode, each angle can be used only 1 hour.																														
	2	Louver	Available	Not available																															
	3	Vane	Available	Not available																															
	4	Vane swing function	Available	Not available																															
	5	Vane horizontal angle	Second setting	First setting																															
	6	Vane cooling limit angle setting	Horizontal angle	Down blow																															
	7	—	—	—																															
	8	Heating 4deg up	Not effective	Effective																															
SW4 Unit Selection	1~4	 <At delivery>		<div style="border: 1px solid black; padding: 5px; text-align: center;">Indoor controller board</div> Set while the unit is off.																															
SW5 Voltage Selection	2	 220V 240V If the unit is used at the 230V or 240V area, set the voltage to 240V. If the unit is used at the 220V, set the voltage to 220V.		<div style="border: 1px solid black; padding: 5px; text-align: center;">Address board</div> <At delivery> 220V 240V 																															

Note 1:The DipSW setting is effective during unit stopping (remote controller OFF) for SW1,2,3 and 4 commonly and the power source is not required to reset.

2:The DipSW setting is effective during unit stopping (remote controller OFF) for SW11,12,14 and 5.

7-4. Function the LED of the indoor unit service board

Symbol	Silk display	LED operation under normal state
LED1	Main power source	At applying main power source → Lighting
LED2	Transmission power source	At receiving M-NET transmission power source → Lighting

8-1 CONTROL BOX (Exposed type PFFY-NEMU)

Be careful removing heavy parts.

OPERATING PROCEDURE

1.Removing the front panel (A)

(1)Remove the fixing screws(two) of the front panel(A).(Fig.1)

(2)Hold the bottom of the front panel with your hands,and gently lift it. The front panel should fall down forward.(Fig.2)

2.Removing the control box cover (B)

(1)Remove the fixing screws(two) of the cover(B) and remove the cover.(Fig.3)

PHOTOS

Fig.1

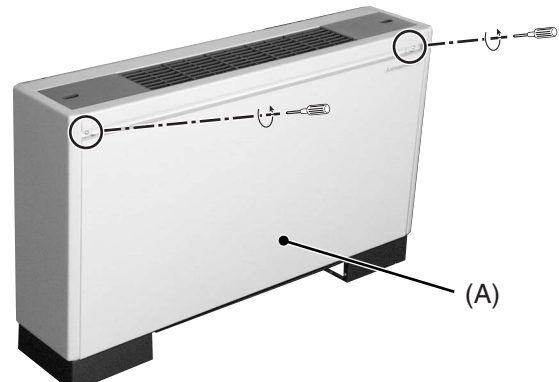

Fig.2

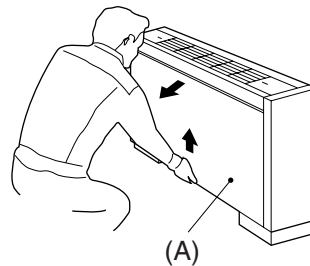
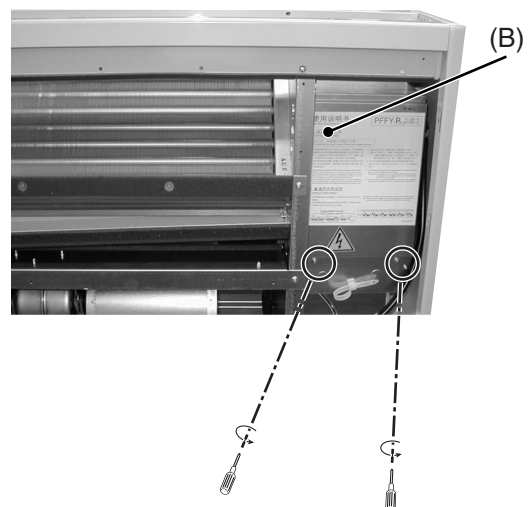
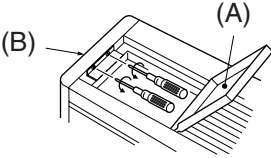
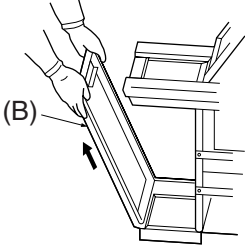
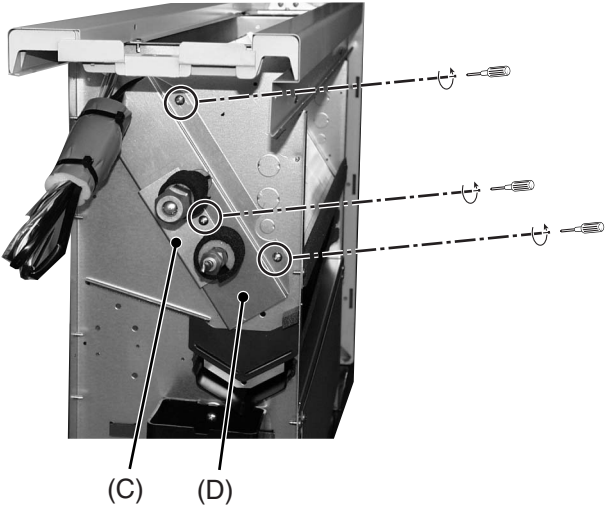
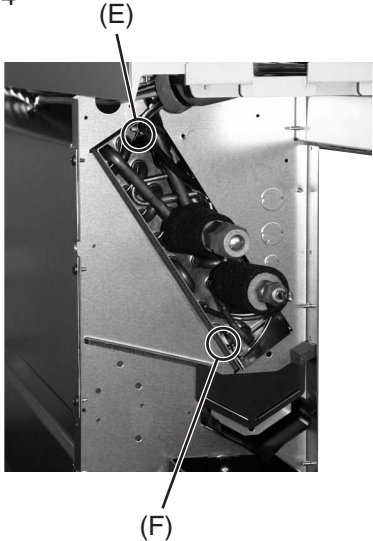

Fig.3



8-2 THERMISTOR (Gas and liquid piping temperature detection)

Be careful removing heavy parts.



OPERATING PROCEDURE	PHOTOS
<p>1.Removing the side casing</p> <p>(1)Open the control panel cover(A), remove the fixing screws(two) of the securing cover. (Fig. 1)</p> <p>(2)Pull up the side casing(B). (Fig. 2)</p> <p>2.Removing the thermistor</p> <p>(1)Remove the fixing screws (three), remove the cover (C) and (D). (Fig. 3)</p> <p>(2)Remove the thermistor (gas)(E) and the thermistor (liquid)(F). (Fig. 4)</p>	 <p>Fig.1</p>  <p>Fig.2</p>  <p>Fig.3</p>  <p>Fig.4</p>

8-3 THERMISTOR (Intake air temperature detection)

Be careful removing heavy parts.

OPERATING PROCEDURE	PHOTOS
<p>1.Removing the thermistor (1)Remove the thermistor under the control box.</p>	<p>Fig.1</p>  <p>Thermistor</p>

8-4 DRAINPAN

OPERATING PROCEDURE	PHOTOS
<p>1.Removing the drainpan (1)Remove the fixing screw of the side frame by the control box. (Fig. 1) (2)Slide the drainpan in the direction of the arrow ①.</p>	<p>Fig.1</p>  <p>Fig.2</p> 

8-5 FAN and FAN MOTOR

Be careful removing heavy parts.

OPERATING PROCEDURE

1.Sliding the fan section (Fig.1)

- (1)Remove the fixing screws(two) (a).
- (2)Slide the fan section in direction of the arrow ①.

2.Removing the fan motor (Fig.2)

- (1)Remove the fixing screws (two)(b) of the fan casing(A).
- (2)Remove the fan motor shaft fixing screw and remove the fan casing(A) and sirroco fan.
- (3)Remove the fixing screws(two) (c) of the motor fixtures (two) and remove the motor.

Notice:In case of the Model(PFFY-12~24) stick out the motor shafts on both side of the motor.

PHOTOS

Fig.1

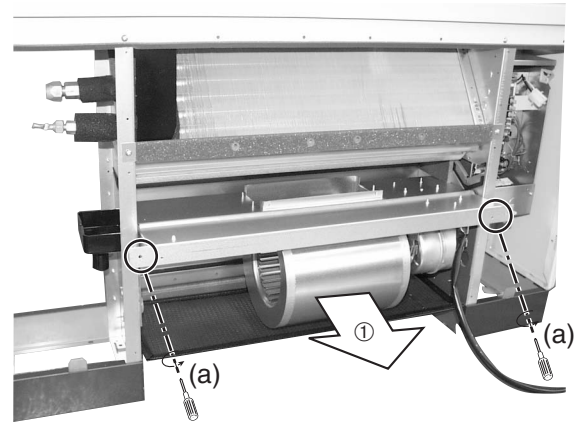
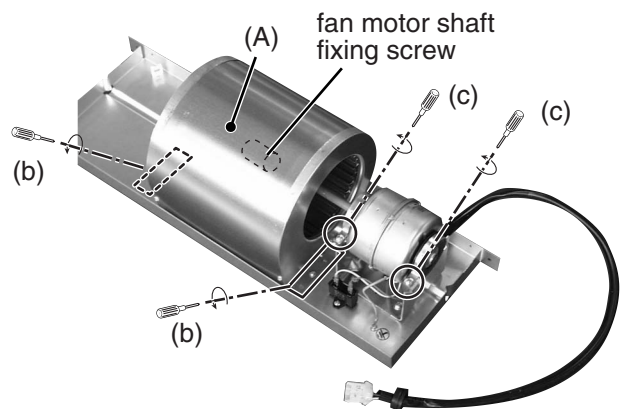

Fig.2



8-6 HEAT EXCHANGER

Be careful removing heavy parts.

OPERATING PROCEDURE

1.Removing the casing

(1)Remove the fixing screws(six) and remove the casing. (Fig. 1)

2.Removing the cover1,2 with procedure 8-2

(Fig. 2)

3.Removing the Heat exchanger

(1)Remove the fixing screws(four) and remove the heat exchanger support. (Fig. 3)

(2)Remove the heat exchanger, moving from side to side.

PHOTOS

Fig.1

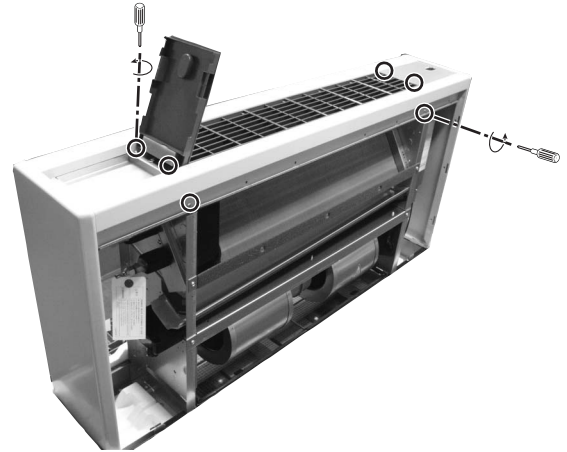

Fig.2

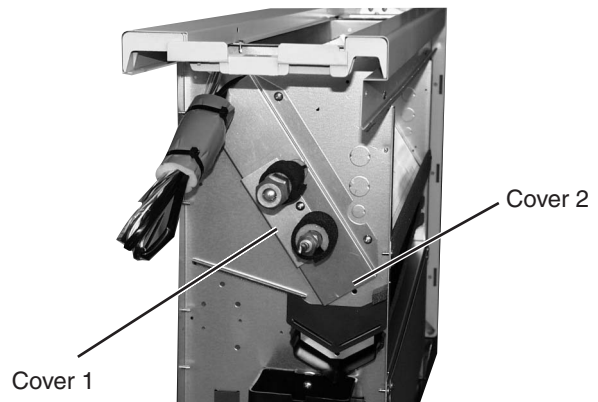
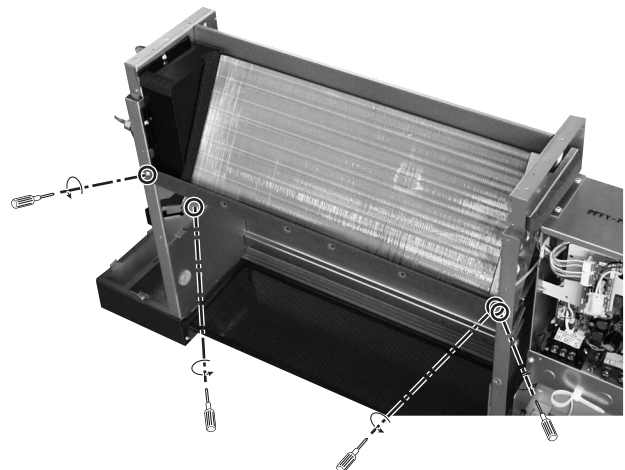

Fig.3



8-7 CASING (Concealed type PFFY-NRMU)

Be careful removing heavy parts.

OPERATING PROCEDURE

1.Removing the casing ass'y

(1)Remove the fixing screws (nine) of the plate(A) and remove the plate. (Fig. 1)

2.Removing the air diffuser ass'y

(1)Remove the fixing screws (eight) of the air diffuser ass'y(B) and remove it. (Fig. 2)

Note: Without this section, almost the disassembly procedures are same as Exposed type (PFFY-NEMU) and Concealed type (PFFY-NRMU).

PHOTOS

Fig.1

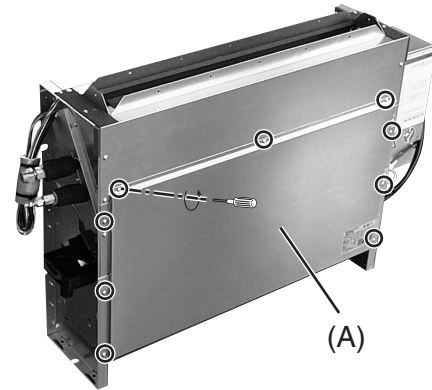

Fig.2

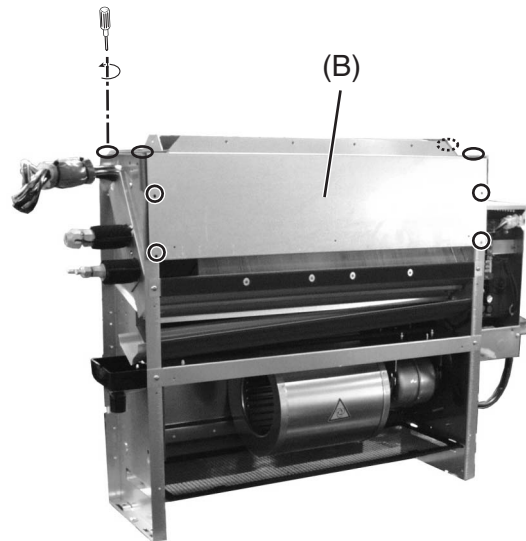
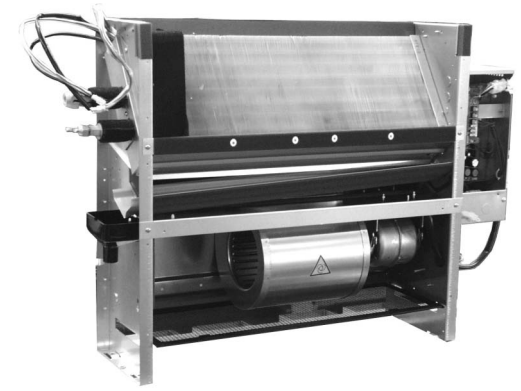

Fig.3





HEAD OFFICE: MITSUBISHI DENKI BLDG., 2-2-3, MARUNOUCHI, CHIYODA-KU, TOKYO 100-8310, JAPAN
