

Service Handbook

Model

PQHY-P72, P96, P120, P144, P168, P192, P216, P240T(Y)LMU-A1

PQHY-P144, P168, P192, P216, P240, P288, P312, P336, P360T(Y)SLMU-A1

PQRY-P72, P96, P120, P144, P168, P192, P216, P240T(Y)LMU-A1

PQRY-P144, P168, P192, P216, P240, P288, P312, P336T(Y)SLMU-A1

Safety Precautions

- Before installing the unit, thoroughly read the following safety precautions.
- Observe these safety precautions for your safety.

WARNING

This symbol is intended to alert the user to the presence of important instructions that must be followed to avoid the risk of serious injury or death.

CAUTION

This symbol is intended to alert the user to the presence of important instructions that must be followed to avoid the risk of serious injury or damage to the unit.

- After reading this manual, give it to the user to retain for future reference.
- Keep this manual for easy reference. When the unit is moved or repaired, give this manual to those who provide these services.
When the user changes, make sure that the new user receives this manual.

WARNING

Ask your dealer or a qualified technician to install the unit.

Improper installation by the user may result in water leakage, electric shock, smoke, and/or fire.

Properly install the unit on a surface that can withstand the weight of the unit.

Unit installed on an unstable surface may fall and cause injury.

Only use specified cables. Securely connect each cable so that the terminals do not carry the weight of the cable.

Improperly connected or fixed cables may produce heat and start a fire.

Take appropriate safety measures against strong winds and earthquakes to prevent the unit from falling.

If the unit is not installed properly, the unit may fall and cause serious injury to the person or damage to the unit.

Do not make any modifications or alterations to the unit. Consult your dealer for repair.

Improper repair may result in water leakage, electric shock, smoke, and/or fire.

Do not touch the heat exchanger fins.

The fins are sharp and dangerous.

In the event of a refrigerant leak, thoroughly ventilate the room.

If refrigerant gas leaks and comes in contact with an open flame, poisonous gases will be produced.

When installing the All-Fresh type units, take it into consideration that the outside air may be discharged directly into the room when the thermo is turned off.

Direct exposure to outdoor air may have an adverse effect on health. It may also result in food spoilage.

Properly install the unit according to the instructions in the installation manual.

Improper installation may result in water leakage, electric shock, smoke, and/or fire.

Have all electrical work performed by an authorized electrician according to the local regulations and instructions in this manual, and a dedicated circuit must be used.

Insufficient capacity of the power supply circuit or improper installation may result in malfunctions of the unit, electric shock, smoke, and/or fire.

 **WARNING**

Securely attach the terminal block cover (panel) to the unit.

If the terminal block cover (panel) is not installed properly, dust and/or water may infiltrate and pose a risk of electric shock, smoke, and/or fire.

Only use the type of refrigerant that is indicated on the unit when installing or reinstalling the unit.

Infiltration of any other type of refrigerant or air into the unit may adversely affect the refrigerant cycle and may cause the pipes to burst or explode.

When installing the unit in a small room, exercise caution and take measures against leaked refrigerant reaching the limiting concentration.

Consult your dealer with any questions regarding limiting concentrations and for precautionary measures before installing the unit. Leaked refrigerant gas exceeding the limiting concentration causes oxygen deficiency.

Consult your dealer or a specialist when moving or re-installing the unit.

Improper installation may result in water leakage, electric shock, and/or fire.

After completing the service work, check for a gas leak.

If leaked refrigerant is exposed to a heat source, such as a fan heater, stove, or electric grill, poisonous gases may be produced.

Do not try to defeat the safety features of the unit.

Forced operation of the pressure switch or the temperature switch by defeating the safety features of these devices, or the use of accessories other than the ones that are recommended by MITSUBISHI may result in smoke, fire, and/or explosion.

Only use accessories recommended by MITSUBISHI.

Ask a qualified technician to install the unit. Improper installation by the user may result in water leakage, electric shock, smoke, and/or fire.

Control box houses high-voltage parts.

When opening or closing the front panel of the control box, do not let it come into contact with any of the internal components. Before inspecting the inside of the control box, turn off the power, keep the unit off for at least 10 minutes, and confirm that the voltage between FT-P and FT-N on INV Board has dropped to DC20V or less. (It takes about 10 minutes to discharge electricity after the power supply is turned off.)

Precautions for handling units for use with R410A

CAUTION

Do not use the existing refrigerant piping.

- ♦A large amount of chlorine that is contained in the residual refrigerant and refrigerator oil in the existing piping may cause the refrigerator oil in the new unit to deteriorate.
- ♦R410A is a high-pressure refrigerant and can cause the existing pipes to burst.

Use refrigerant pipes made of phosphorus deoxidized copper. Keep the inner and outer surfaces of the pipes clean and free of such contaminants as sulfur, oxides, dust, dirt, shaving particles, oil, and water.

These types of contaminants inside the refrigerant pipes may cause the refrigerant oil to deteriorate.

Store the pipes to be installed indoors, and keep both ends of the pipes sealed until immediately before brazing. (Keep elbows and other joints wrapped in plastic.)

Infiltration of dust, dirt, or water into the refrigerant system may cause the refrigerating machine oil to deteriorate or cause the unit to malfunction.

Use a small amount of ester oil, ether oil, or alkylbenzene to coat flares and flanges.

Infiltration of a large amount of mineral oil may cause the refrigerating machine oil to deteriorate.

Charge liquid refrigerant (as opposed to gaseous refrigerant) into the system.

If gaseous refrigerant is charged into the system, the composition of the refrigerant in the cylinder will change and may result in performance loss.

Use a vacuum pump with a reverse-flow check valve.

If a vacuum pump that is not equipped with a reverse-flow check valve is used, the vacuum pump oil may flow into the refrigerant cycle and cause the refrigerating machine oil to deteriorate.

Prepare tools for exclusive use with R410A. Do not use the following tools if they have been used with the conventional refrigerant (gauge manifold, charging hose, gas leak detector, reverse-flow check valve, refrigerant charge base, vacuum gauge, and refrigerant recovery equipment.).

- ♦If the refrigerant or the refrigerating machine oil left on these tools are mixed in with R410A, it may cause the refrigerating machine oil to deteriorate.
- ♦Infiltration of water may cause the refrigerating machine oil to deteriorate.
- ♦Gas leak detectors for conventional refrigerants will not detect an R410A leak because R410A is free of chlorine.

Do not use a charging cylinder.

If a charging cylinder is used, the composition of the refrigerant will change, and the unit may experience power loss.

Exercise special care when handling the tools for use with R410A.

Infiltration of dust, dirt, or water into the refrigerant system may cause the refrigerating machine oil to deteriorate.

Only use refrigerant R410A.

The use of other types of refrigerant that contain chlorine (i.e. R22) may cause the refrigerating machine oil to deteriorate.

Before installing the unit

WARNING

Do not install the unit where a gas leak may occur.

If gaseous refrigerant leaks and piles up around the unit, it may be ignited.

Do not use the unit to keep food items, animals, plants, artifacts, or for other special purposes.

The unit is not designed to preserve food products.

Do not use the unit in an unusual environment.

- ♦ Do not install the unit where a large amount of oil or steam is present or where acidic or alkaline solutions or chemical sprays are used frequently. Doing so may lead to a remarkable drop in performance, electric shock, malfunctions, smoke, and/or fire.
- ♦ The presence of organic solvents or corrosive gas (i.e. ammonia, sulfur compounds, and acid) may cause gas leakage or water leakage.

When installing the unit in a hospital, take appropriate measures to reduce noise interference.

High-frequency medical equipment may interfere with the normal operation of the air conditioner or vice versa.

Do not install the unit on or over things that cannot get wet.

When the humidity level exceeds 80% or if the drainage system is clogged, the indoor unit may drip water. Drain water is also discharged from the heat source unit. Install a centralized drainage system if necessary.

Before installing the unit (moving and reinstalling the unit) and performing electrical work

CAUTION

Properly ground the unit.

Do not connect the grounding wire to a gas pipe, water pipe, lightning rod, or grounding wire from a telephone pole. Improper grounding may result in electric shock, smoke, fire, and/or malfunction due to noise interference.

Do not put tension on the power supply wires.

If tension is put on the wires, they may break and result in excessive heat, smoke, and/or fire.

Install an earth leakage breaker to avoid the risk of electric shock.

Failure to install an earth leakage breaker may result in electric shock, smoke, and/or fire.

Use the kind of power supply wires that are specified in the installation manual.

The use of wrong kind of power supply wires may result in current leak, electric shock, and/or fire.

Use breakers and fuses (current breaker, remote switch <switch + Type-B fuse>, moulded case circuit breaker) with the proper current capacity.

The use of wrong capacity fuses, steel wires, or copper wires may result in malfunctions, smoke, and/or fire.

Do not spray water on the air conditioner or immerse the air conditioner in water.

Otherwise, electric shock and/or fire may result.

When handling units, always wear protective gloves to protect your hands from metal parts and high-temperature parts.

Periodically check the installation base for damage.

If the unit is left on a damaged platform, it may fall and cause injury.

Properly install the drain pipes according to the instructions in the installation manual. Keep them insulated to avoid dew condensation.

Improper plumbing work may result in water leakage and damage to the furnishings.

Exercise caution when transporting products.

- Products weighing more than 20 kg should not be carried alone.
- Do not carry the product by the PP bands that are used on some products.
- Do not touch the heat exchanger fins. They are sharp and dangerous.
- When lifting the unit with a crane, secure all four corners to prevent the unit from falling.

Properly dispose of the packing materials.

- Nails and wood pieces in the package may pose a risk of injury.
- Plastic bags may pose a risk of choking hazard to children. Tear plastic bags into pieces before disposing of them.

Before the test run

 **CAUTION**

Turn on the unit at least 12 hours before the test run.

Keep the unit turned on throughout the season. If the unit is turned off in the middle of a season, it may result in malfunctions.

To avoid the risk of electric shock or malfunction of the unit, do not operate switches with wet hands.

Do not touch the refrigerant pipes with bare hands during and immediately after operation.

During or immediately after operation, certain parts of the unit such as pipes and compressor may be either very cold or hot, depending on the state of the refrigerant in the unit at the time. To reduce the risk of frost bites and burns, do not touch these parts with bare hands.

Do not operate the unit without panels and safety guards.

Rotating, high-temperature, or high-voltage parts on the unit pose a risk of burns and/or electric shock.

Do not turn off the power immediately after stopping the operation.

Keep the unit on for at least five minutes before turning off the power to prevent water leakage or malfunction.

Do not operate the unit without the air filter.

Dust particles may build up in the system and cause malfunctions.

CONTENTS

I Read Before Servicing

[1] Read Before Servicing	3
[2] Necessary Tools and Materials	4
[3] Piping Materials	5
[4] Storage of Piping	7
[5] Pipe Processing	7
[6] Brazing	8
[7] Air Tightness Test	9
[8] Vacuum Drying (Evacuation)	10
[9] Refrigerant Charging	12
[10] Remedies to be taken in case of a Refrigerant Leak	12
[11] Characteristics of the Conventional and the New Refrigerants	13
[12] Notes on Refrigerating Machine Oil	14
[13] Precautions for servicing	15

II Restrictions

[1] System configuration	19
[2] Types and Maximum allowable Length of Cables	21
[3] Switch Settings and Address Settings	23
[4] Sample System Connection	29
[5] An Example of a System to which an MA Remote Controller is connected	30
[6] An Example of a System to which an ME Remote Controller is connected	52
[7] An Example of a System to which both MA Remote Controller and ME Remote Controller are connected	56
[8] Restrictions on Pipe Length	61

III Heat source Unit Components

[1] Heat source Unit Components and Refrigerant Circuit	79
[2] Control Box of the Heat source Unit	87
[3] Heat source Unit Circuit Board	93
[4] BC Controller Components	105
[5] Control Box of the BC Controller	108
[6] BC Controller Circuit Board	109

IV Remote Controller

[1] Functions and Specifications of MA and ME Remote Controllers	113
[2] Group Settings and Interlock Settings via the ME Remote Controller	114
[3] Interlock Settings via the MA Remote Controller	118
[4] Using the built-in Temperature Sensor on the Remote Controller	119

V Electrical Wiring Diagram

[1] Electrical Wiring Diagram of the Heat source Unit	123
[2] Electrical Wiring Diagram of the BC Controller	127
[3] Electrical Wiring Diagram of Transmission Booster	137

VI Refrigerant Circuit

[1] Refrigerant Circuit Diagram	141
[2] Principal Parts and Functions	147

VII Control

[1] Functions and Factory Settings of the Dipswitches	159
[2] Controlling the Heat source Unit	166
[3] Controlling BC Controller	181
[4] Operation Flow Chart	182

VIII Test Run Mode

[1] Items to be checked before a Test Run	195
[2] Test Run Method	196
[3] Operating Characteristic and Refrigerant Amount	199
[4] Adjusting the Refrigerant Amount	199
[5] Refrigerant Amount Adjust Mode	204
[6] The following symptoms are normal.	208
[7] Standard Operation Data (Reference Data)	209

IX Troubleshooting

[1] Error Code Lists	261
[2] Responding to Error Display on the Remote Controller	265
[3] Investigation of Transmission Wave Shape/Noise	347
[4] Troubleshooting Principal Parts	350
[5] Refrigerant Leak	402

CONTENTS

[6] Compressor Replacement Instructions.....	406
[7] Water-cooled heat exchanger Replacement Instructions.....	409
[8] Servicing the BC controller	421
[9] Troubleshooting Using the Heat source Unit LED Error Display	424
X LED Monitor Display on the Heat source Unit Board	
[1] How to Read the LED on the Service Monitor	427

I Read Before Servicing

[1] Read Before Servicing	3
[2] Necessary Tools and Materials	4
[3] Piping Materials	5
[4] Storage of Piping	7
[5] Pipe Processing	7
[6] Brazing	8
[7] Air Tightness Test	9
[8] Vacuum Drying (Evacuation)	10
[9] Refrigerant Charging	12
[10] Remedies to be taken in case of a Refrigerant Leak	12
[11] Characteristics of the Conventional and the New Refrigerants	13
[12] Notes on Refrigerating Machine Oil	14
[13] Precautions for servicing	15



[1] Read Before Servicing

1. Check the type of refrigerant used in the system to be serviced.

Refrigerant Type

Multi air conditioner for building application CITY MULTI WY/WR2 TLMU-A/YLMU-A1 series: R410A

2. Check the symptoms exhibited by the unit to be serviced.

Refer to this service handbook for symptoms relating to the refrigerant cycle.

3. Thoroughly read the safety precautions at the beginning of this manual.

4. Preparing necessary tools: Prepare a set of tools to be used exclusively with each type of refrigerant.

Refer to "Necessary Tools and Materials" for information on the use of tools.(page 4)

5. Verification of the connecting pipes: Verify the type of refrigerant used for the unit to be moved or replaced.

- ♦Use refrigerant pipes made of phosphorus deoxidized copper. Keep the inner and outer surfaces of the pipes clean and free of such contaminants as sulfur, oxides, dust, dirt, shaving particles, oil, and water.
- ♦These types of contaminants inside the refrigerant pipes may cause the refrigerant oil to deteriorate.

6. If there is a leak of gaseous refrigerant and the remaining refrigerant is exposed to an open flame, a poisonous gas hydrofluoric acid may form. Keep workplace well ventilated.



CAUTION

- ♦Install new pipes immediately after removing old ones to keep moisture out of the refrigerant circuit.
- ♦The use of refrigerant that contains chloride, such as R22, will cause the refrigerating machine oil to deteriorate.

[2] Necessary Tools and Materials

Prepare the following tools and materials necessary for installing and servicing the unit.

Tools for use with R410A (Adaptability of tools that are for use with R22 or R407C)

1. To be used exclusively with R410A (not to be used if used with R22 or R407C)

Tools/Materials	Use	Notes
Gauge Manifold	Evacuation and refrigerant charging	Higher than 5.09MPa[738psi] on the high-pressure side
Charging Hose	Evacuation and refrigerant charging	The hose diameter is larger than the conventional model.
Refrigerant Recovery Cylinder	Refrigerant recovery	
Refrigerant Cylinder	Refrigerant charging	The refrigerant type is indicated. The cylinder is pink.
Charging Port on the Refrigerant Cylinder	Refrigerant charging	The charge port diameter is larger than that of the current port.
Flare Nut	Connection of the unit with the pipes	Use Type-2 Flare nuts.

2. Tools and materials that may be used with R410A with some restrictions

Tools/Materials	Use	Notes
Gas Leak Detector	Gas leak detection	The ones for use with HFC refrigerant may be used.
Vacuum Pump	Vacuum drying	May be used if a check valve adapter is attached.
Flare Tool	Flare processing	Flare processing dimensions for the piping in the system using the new refrigerant differ from those of R22. Refer to I [3] Piping Materials.
Refrigerant Recovery Equipment	Refrigerant recovery	May be used if compatible with R410A.

3. Tools and materials that are used with R22 or R407C that may also be used with R410A

Tools/Materials	Use	Notes
Vacuum Pump with a Check Valve	Vacuum drying	
Bender	Bending pipes	
Torque Wrench	Tightening flare nuts	Only the flare processing dimensions for pipes that have a diameter of $\varnothing 12.70$ (1/2") and $\varnothing 15.88$ (5/8") have been changed.
Pipe Cutter	Cutting pipes	
Welder and Nitrogen Cylinder	Welding pipes	
Refrigerant Charging Meter	Refrigerant charging	
Vacuum Gauge	Vacuum level check	

4. Tools and materials that must not be used with R410A

Tools/Materials	Use	Notes
Charging Cylinder	Refrigerant charging	Prohibited to use

Tools for R410A must be handled with special care to keep moisture and dust from infiltrating the cycle.

[3] Piping Materials

Do not use the existing piping!

1. Copper pipe materials

O-material (Annealed)	Soft copper pipes (annealed copper pipes). They can easily be bent with hands.
1/2H-material (Drawn)	Hard copper pipes (straight pipes). They are stronger than the O-material (Annealed) at the same radial thickness.

♦The distinction between O-materials (Annealed) and 1/2H-materials (Drawn) is made based on the strength of the pipes themselves.

2. Types of copper pipes

Maximum working pressure	Refrigerant type
3.45 MPa [500psi]	R22, R407C etc.
4.30 MPa [624psi]	R410A etc.

3. Piping materials/Radial thickness

Use refrigerant pipes made of phosphorus deoxidized copper.

The operation pressure of the units that use R410A is higher than that of the units that use R22.

Use pipes that have at least the radial thickness specified in the chart below.

(Pipes with a radial thickness of 0.7 mm or less may not be used.)

Pipe size (mm[in])	Radial thickness (mm)	Type
ø6.35 [1/4"]	0.8t	O-material (Annealed)
ø9.52 [3/8"]	0.8t	
ø12.7 [1/2"]	0.8t	
ø15.88 [5/8"]	1.0t	1/2H-material, H-material (Drawn)
ø19.05 [3/4"]	1.0t	
ø22.2 [7/8"]	1.0t	
ø25.4 [1"]	1.0t	
ø28.58 [1-1/8"]	1.0t	
ø31.75 [1-1/4"]	1.1t	
ø34.93 [1-3/8"]	1.1t	
ø41.28 [1-5/8"]	1.2t	

♦Annealed pipes have been used for older model units when a diameter of the pipe is up to ø19.05(3/4"). For a system that uses R410A, use pipes that are made with 1/2H-material (Drawn) when a diameter of the pipe is more than ø19.05(3/4"). (Annealed pipes may be used for pipes with a diameter of ø19.05 (3/4") and a radial thickness of 1.2 t).

♦The figures in the radial thickness column are based on the Japanese standards and provided only as a reference. Use pipes that meet the local standards.

4. Thickness and refrigerant type indicated on the piping materials

Ask the pipe manufacturer for the symbols indicated on the piping material for new refrigerant.

5. Flare processing (O-material (Annealed) and OL-material only)

The flare processing dimensions for the pipes that are used in the R410A system are larger than those in the R22 system.

Flare processing dimensions (mm[in])

Pipe size (mm[in])	A dimension (mm)	
	R410A	R22, R407C
ø6.35 [1/4"]	9.1	9.0
ø9.52 [3/8"]	13.2	13.0
ø12.7 [1/2"]	16.6	16.2
ø15.88 [5/8"]	19.7	19.4
ø19.05 [3/4"]	24.0	23.3

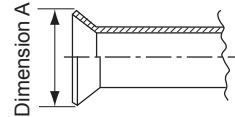

(ø19.05 pipes should have a radial thickness of 1.2 t and be made of annealed materials.)

If a clutch-type flare tool is used to flare the pipes in the system using R410A, the length of the pipes must be between 1.0 and 1.5 mm. For margin adjustment, a copper pipe gauge is necessary.

6. Flare nut

The flare nut type has been changed to increase the strength. The size of some of the flare nuts have also been changed.

Flare nut dimensions (mm[in])

Pipe size (mm[in])	B dimension (mm)	
	R410A	R22, R407C
ø6.35 [1/4"]	17.0	17.0
ø9.52 [3/8"]	22.0	22.0
ø12.7 [1/2"]	26.0	24.0
ø15.88 [5/8"]	29.0	27.0
ø19.05 [3/4"]	36.0	36.0

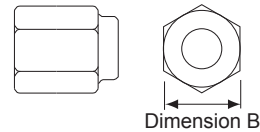

The figures in the radial thickness column are based on the Japanese standards and provided only as a reference. Use pipes that meet the local standards.

[4] Storage of Piping

1. Storage location

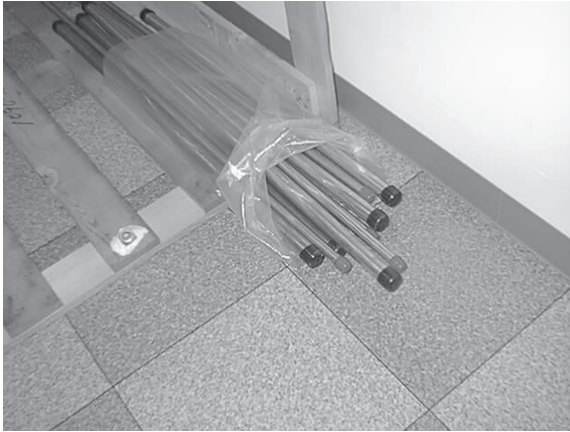

Store the pipes to be used indoors. (Warehouse at site or owner's warehouse)
If they are left outdoors, dust, dirt, or moisture may infiltrate and contaminate the pipe.

2. Sealing the pipe ends

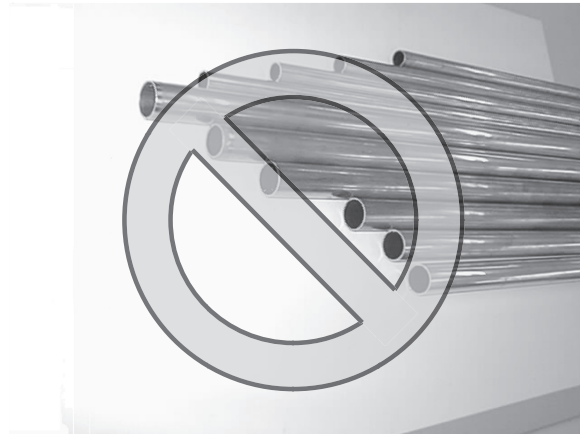
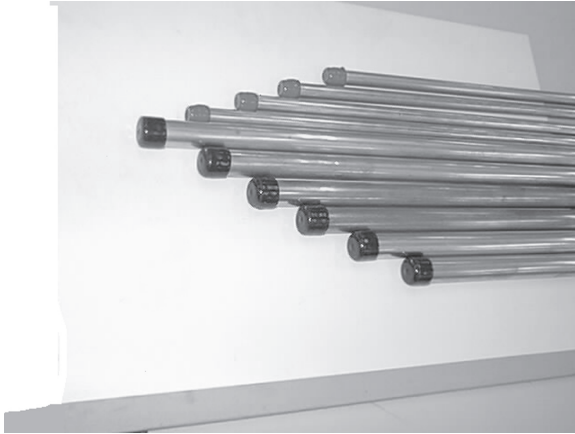

Both ends of the pipes should be sealed until just before brazing.
Keep elbow pipes and T-joints in plastic bags.

The new refrigerator oil is 10 times as hygroscopic as the conventional refrigerating machine oil (such as Suniso) and, if not handled with care, could easily introduce moisture into the system. Keep moisture out of the pipes, for it will cause the oil to deteriorate and cause a compressor failure.

[5] Pipe Processing

Use a small amount of ester oil, ether oil, or alkylbenzene to coat flares and flanges.

Note

- Use a minimum amount of oil.
- Use only ester oil, ether oil, and alkylbenzene.

[6] Brazing

No changes have been made in the brazing procedures. Perform brazing with special care to keep foreign objects (such as oxide scale, water, and dust) out of the refrigerant system.

Example: Inside the brazed connection

Use of oxidized solder for brazing

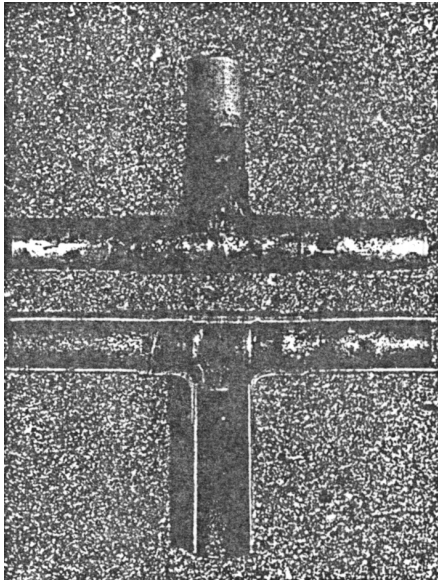

Use of non-oxidized solder for brazing

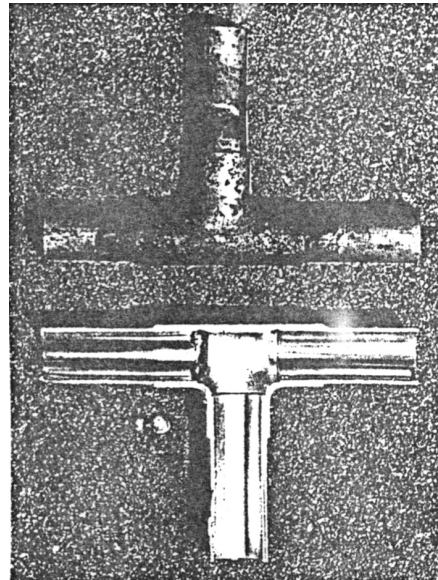

1. Items to be strictly observed

- ♦Do not conduct refrigerant piping work outdoors if raining.
- ♦Use non-oxidized solder.
- ♦Use a brazing material (BCuP-3) that requires no flux when brazing between copper pipes or between a copper pipe and copper coupling.
- ♦If installed refrigerant pipes are not immediately connected to the equipment, then braze and seal both ends.

2. Reasons

- ♦The new refrigerating machine oil is 10 times as hygroscopic as the conventional oil and is more likely to cause unit failure if water infiltrates into the system.
- ♦Flux generally contains chloride. Residual flux in the refrigerant circuit will cause sludge to form.

3. Notes

Do not use commercially available antioxidants because they may cause the pipes to corrode or refrigerating machine oil to deteriorate.

[7] Air Tightness Test

No changes have been made in the detection method. Note that a refrigerant leak detector for R22 will not detect an R410A leak.

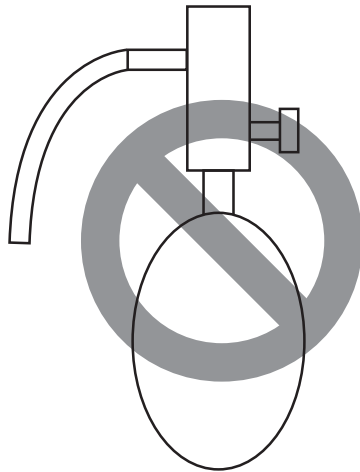

Halide torch

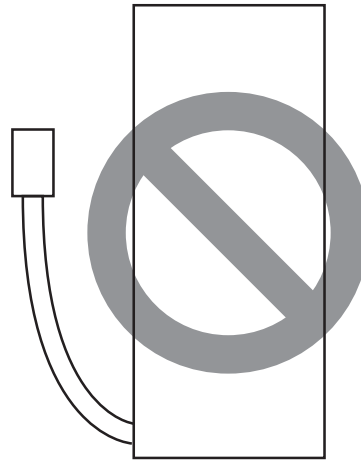

R22 leakage detector

1. Items to be strictly observed

- ♦Pressurize the equipment with nitrogen up to the design pressure (4.15MPa[601psi]), and then judge the equipment's air tightness, taking temperature variations into account.
- ♦Refrigerant R410A must be charged in its liquid state (vs. gaseous state).

2. Reasons

- ♦Oxygen, if used for an air tightness test, poses a risk of explosion. (Only use nitrogen to check air tightness.)
- ♦Refrigerant R410A must be charged in its liquid state. If gaseous refrigerant in the cylinder is drawn out first, the composition of the remaining refrigerant in the cylinder will change and become unsuitable for use.

3. Notes

Procure a leak detector that is specifically designed to detect an HFC leak. A leak detector for R22 will not detect an HFC(R410A) leak.

[8] Vacuum Drying (Evacuation)



(Photo1) 15010H



(Photo2) 14010

Recommended vacuum gauge:
ROBINAIR 14010 Thermistor Vacuum Gauge

1. Vacuum pump with a reverse-flow check valve (Photo1)

To prevent the vacuum pump oil from flowing into the refrigerant circuit during power OFF or power failure, use a vacuum pump with a reverse-flow check valve.
A reverse-flow check valve may also be added to the vacuum pump currently in use.

2. Standard of vacuum degree (Photo 2)

Use a vacuum pump that attains 0.5Torr(65Pa) or lower degree of vacuum after 5 minutes of operation, and connect it directly to the vacuum gauge. Use a pump well-maintained with an appropriate lubricant. A poorly maintained vacuum pump may not be able to attain the desired degree of vacuum.

3. Required precision of vacuum gauge

Use a vacuum gauge that registers a vacuum degree of 5Torr(650Pa) and measures at intervals of 1Torr(130Pa). (A recommended vacuum gauge is shown in Photo2.)
Do not use a commonly used gauge manifold because it cannot register a vacuum degree of 5Torr(650Pa).

4. Evacuation time

- After the degree of vacuum has reached 5Torr(650Pa), evacuate for an additional 1 hour. (A thorough vacuum drying removes moisture in the pipes.)
- Verify that the vacuum degree has not risen by more than 1Torr(130Pa) 1hour after evacuation. A rise by less than 1Torr(130Pa) is acceptable.
- If the vacuum is lost by more than 1Torr(130Pa), conduct evacuation, following the instructions in section 6. Special vacuum drying.

5. Procedures for stopping vacuum pump

To prevent the reverse flow of vacuum pump oil, open the relief valve on the vacuum pump side, or draw in air by loosening the charge hose, and then stop the operation.
The same procedures should be followed when stopping a vacuum pump with a reverse-flow check valve.

6. Special vacuum drying

- When 5Torr(650Pa) or lower degree of vacuum cannot be attained after 3 hours of evacuation, it is likely that water has penetrated the system or that there is a leak.
- If water infiltrates the system, break the vacuum with nitrogen. Pressurize the system with nitrogen gas to 0.5kgf/cm²G(0.05MPa) and evacuate again. Repeat this cycle of pressurizing and evacuation either until the degree of vacuum below 5Torr(650Pa) is attained or until the pressure stops rising.
- Only use nitrogen gas for vacuum breaking. (The use of oxygen may result in an explosion.)

7. Notes

♦To evacuate air from the entire system

Applying a vacuum through the check joints at the refrigerant service valve (BV1 and 2) is not enough to attain the desired vacuum pressure.

Be sure to apply a vacuum through the check joints at the refrigerant service valve (BV1 and 2) and also through the check joints on the high and low pressure sides (CJ1 and 2).

♦To evacuate air only from the heat source units

Apply a vacuum through the check joints on the high and low pressure sides (CJ1, and 2).

♦To evacuate air from the indoor units and extension pipes

Apply a vacuum through the check joints at the refrigerant service valve (BV1 and 2).

[9] Refrigerant Charging

Cylinder with a siphon

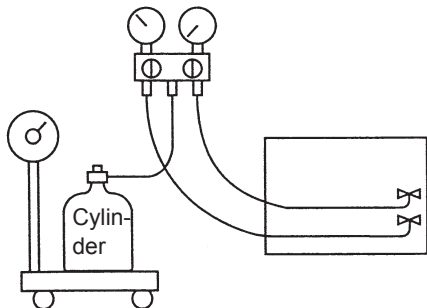

Cylinder color R410A is pink.

Cylinder without a siphon

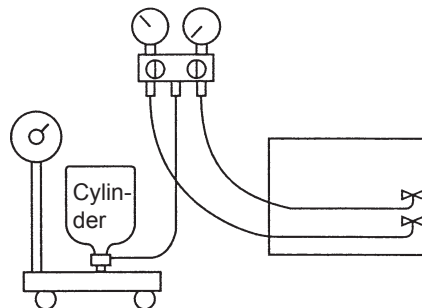

Refrigerant charging in the liquid state

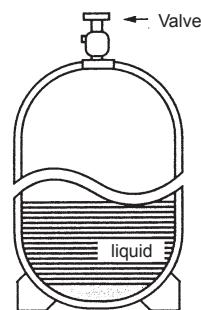
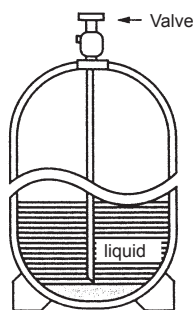

1. Reasons

R410A is a pseudo-azeotropic HFC blend (boiling point R32=-52°C[-62°F], R125=-49°C[-52°F]) and can almost be handled the same way as a single refrigerant, such as R22. To be safe, however, draw out the refrigerant from the cylinder in the liquid phase. If the refrigerant in the gaseous phase is drawn out, the composition of the remaining refrigerant will change and become unsuitable for use.

2. Notes

When using a cylinder with a siphon, refrigerant is charged in the liquid state without the need for turning it upside down. Check the type of the cylinder on the label before use.

[10] Remedies to be taken in case of a Refrigerant Leak

If the refrigerant leaks out, it may be replenished. The entire refrigerant does not need to be replaced. (Charge refrigerant in the liquid state.)

Refer to "IX [5] Refrigerant Leak."(page 402)

[11] Characteristics of the Conventional and the New Refrigerants

1. Chemical property

As with R22, the new refrigerant (R410A) is low in toxicity and chemically stable nonflammable refrigerant. However, because the specific gravity of vapor refrigerant is greater than that of air, leaked refrigerant in a closed room will accumulate at the bottom of the room and may cause hypoxia. If exposed to an open flame, refrigerant will generate poisonous gases. Do not perform installation or service work in a confined area.

	New Refrigerant (HFC type)		Conventional Refrigerant (HCFC type)
	R410A	R407C	R22
	R32/R125	R32/R125/R134a	R22
Composition (wt%)	(50/50)	(23/25/52)	(100)
Type of Refrigerant	Pseudo-azeotropic Refrigerant	Non-azeotropic Refrigerant	Single Refrigerant
Chloride	Not included	Not included	Included
Safety Class	A1/A1	A1/A1	A1
Molecular Weight	72.6	86.2	86.5
Boiling Point (°C/°F)	-51.4/-60.5	-43.6/-46.4	-40.8/-41.4
Steam Pressure (25°C,MPa/77°F,psi) (gauge)	1.557/226	0.9177/133	0.94/136
Saturated Steam Density (25°C,kg/m ³ /77°F,psi)	64.0	42.5	44.4
Flammability	Nonflammable	Nonflammable	Nonflammable
Ozone Depletion Coefficient (ODP)^{*1}	0	0	0.055
Global Warming Coefficient (GWP) ^{*2}	2088	1774	1810
Refrigerant Charging Method	Refrigerant charging in the liquid state	Refrigerant charging in the liquid state	Refrigerant charging in the gaseous state
Replenishment of Refrigerant after a Refrigerant Leak	Available	Available	Available

*1 When CFC11 is used as a reference

*2 When CO₂ is used as a reference

2. Refrigerant composition

R410A is a pseudo-azeotropic HFC blend and can almost be handled the same way as a single refrigerant, such as R22. To be safe, however, draw out the refrigerant from the cylinder in the liquid phase. If the refrigerant in the gaseous phase is drawn out, the composition of the remaining refrigerant will change and become unsuitable for use. If the refrigerant leaks out, it may be replenished. The entire refrigerant does not need to be replaced.

3. Pressure characteristics

The pressure in the system using R410A is 1.6 times as great as that in the system using R22.

Temperature (°C/°F)	Pressure (gauge)		
	R410A	R407C	R22
	MPa/psi	MPa/psi	MPa/psi
-20/-4	0.30/44	0.18/26	0.14/20
0/32	0.70/102	0.47/68	0.40/58
20/68	1.34/194	0.94/136	0.81/117
40/104	2.31/335	1.44/209	1.44/209
60/140	3.73/541	2.44/354	2.33/338
65/149	4.17/605	2.75/399	2.60/377

[12] Notes on Refrigerating Machine Oil

1. Refrigerating machine oil in the HFC refrigerant system

HFC type refrigerants use a refrigerating machine oil different from that used in the R22 system.
 Note that the ester oil used in the system has properties that are different from commercially available ester oil.

Refrigerant	Refrigerating machine oil
R22	Mineral oil
R407C	Ester oil
R410A	Ester oil

2. Effects of contaminants*1

Refrigerating machine oil used in the HFC system must be handled with special care to keep contaminants out.
 The table below shows the effect of contaminants in the refrigerating machine oil on the refrigeration cycle.

3. The effects of contaminants in the refrigerating machine oil on the refrigeration cycle.

Cause		Symptoms	Effects on the refrigerant cycle
Water infiltration		Frozen expansion valve and capillary tubes	Clogged expansion valve and capillary tubes Poor cooling performance Compressor overheat Motor insulation failure Burnt motor Coppering of the orbiting scroll Lock Burn-in on the orbiting scroll
	Hydrolysis	Sludge formation and adhesion Acid generation Oxidization Oil degradation	
Air infiltration		Oxidization	
Infiltration of contaminants	Dust, dirt	Adhesion to expansion valve and capillary tubes	Clogged expansion valve, capillary tubes, and drier Poor cooling performance Compressor overheat
		Infiltration of contaminants into the compressor	Burn-in on the orbiting scroll
	Mineral oil etc.	Sludge formation and adhesion	Clogged expansion valve and capillary tubes Poor cooling performance Compressor overheat
		Oil degradation	Burn-in on the orbiting scroll

*1. Contaminants is defined as moisture, air, processing oil, dust/dirt, wrong types of refrigerant, and refrigerating machine oil.

[13] Precautions for servicing

- Control boxes house high-voltage and high-temperature electrical parts.
- They may still remain energized or hot after the power is turned off.
- When opening or closing the front cover of the control box, keep out of contact with the internal parts.
Before inspecting the inside of the control box, turn off the power, leave the unit turned off for at least 10 minutes, and check that the voltage of the electrolytic capacitor (inverter main circuit) has dropped to 20 VDC or less.
- When the unit is turned on, the compressor will remain energized even when it is stopped to vaporize the liquid refrigerant that accumulates in the compressor.
- When replacing the internal electrical components of the control box, tighten the screws to the recommended tightening torque as specified below.
Recommended tightening torque for the internal electrical components of the control box

Screw	Recommended tightening torque (N·m)
M3	0.69
M3.5	0.95
M4	1.47
M5	2.55
M6	2.75
M8	6.20

- *1 When replacing semiconductor modules (e.g., diode stack, IPM, INV board (with IPM)), apply heatsink silicone evenly to the mounting surface of the semiconductor module (or the semiconductor module on the back of the circuit board). Next, tighten the screws holding the semiconductor module to one-third of the specified torque, and then tighten the screws to the specified torque.
- *2 Deviating from the recommended tightening torque may cause damage to the unit or its parts.

Take the following steps to ensure that the screws are properly tightened.

- 1) Ensure that the spring washers are parallel to the terminal block.
Even if the tightening torque is observed, if the washers are not parallel to the terminal block, then the semiconductor module is not installed properly.

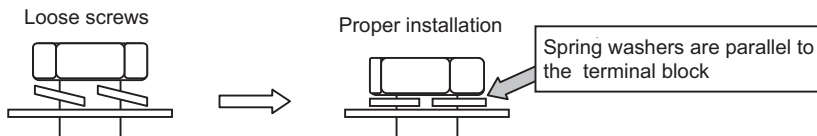

- 2) Check the wires are securely fastened to the screw terminals.
 - Screw the screws straight down so as not to damage the screw threads.**
Hold the two round terminals back to back to ensure that the screw will screw down straight.
 - After tightening the screw, mark a line through the screw head, washer, and terminals with a permanent marker.**

Example

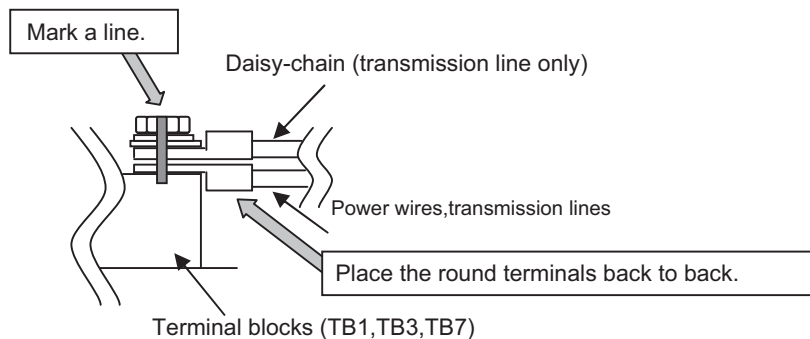

Poor contact caused by loose screws may result in overheating and fire.
Continued use of the damaged circuit board may cause overheating and fire.

II Restrictions

[1] System configuration	19
[2] Types and Maximum allowable Length of Cables	21
[3] Switch Settings and Address Settings	23
[4] Sample System Connection.....	29
[5] An Example of a System to which an MA Remote Controller is connected.....	30
[6] An Example of a System to which an ME Remote Controller is connected.....	52
[7] An Example of a System to which both MA Remote Controller and ME Remote Controller are connected.....	56
[8] Restrictions on Pipe Length.....	61



[1] System configuration

1. Table of compatible indoor units <PQHY>

The table below summarizes the types of indoor units that are compatible with different types of heat source units.

Heat source units	Composing units		Maximum total capacity of connectable indoor units	Maximum number of connectable indoor units	Types of connectable indoor units
P72	-	-	36 - 93	1 - 15	P06 - P96 models R410A series indoor units
P96	-	-	48 - 124	1 - 20	
P120	-	-	60 - 156	1 - 26	
P144	-	-	72 - 187	1 - 31	
P168	-	-	84 - 218	1 - 36	
P192	-	-	96 - 249	1 - 41	
P216	-	-	108 - 280	2 - 46	
P240	-	-	120 - 312	2 - 50	
P144	P72	P72	72 - 187	1 - 31	
P168	P96	P72	84 - 218	1 - 36	
P192	P96	P96	96 - 249	1 - 41	
P216	P120	P96	108 - 280	2 - 46	
P240	P120	P120	120 - 312	2 - 50	
P288	P144	P144	144 - 374		
P312	P168	P144	156 - 405		
P336	P168	P168	168 - 436		
P360	P192	P168	180 - 468		

Note

- 1) "Maximum total capacity of connectable indoor units" refers to the sum of the numeric values in the indoor unit model names.
- 2) If the total capacity of the indoor units that are connected to a given heat source unit exceeds the capacity of the heat source unit, the indoor units will not be able to perform at the rated capacity when they are operated simultaneously. Select a combination of units so that the total capacity of the connected indoor units is at or below the capacity of the heat source unit whenever possible.

1. Table of compatible indoor units <PQRY>

The table below summarizes the types of indoor units that are compatible with different types of heat source units.

Heat source units	Composing units		Maximum total capacity of connectable indoor units	Maximum number of connectable indoor units	Types of connectable indoor units
P72	-	-	36 - 108	1 - 18	P06 - P96 models R410A series indoor units
P96	-	-	48 - 144	1 - 24	
P120	-	-	60 - 180	1 - 30	
P144	-	-	72 - 216	1 - 36	
P168	-	-	84 - 252	1 - 42	
P192	-	-	96 - 288	1 - 48	
P216	-	-	108 - 324	2 - 50	
P240	-	-	120 - 360	2 - 50	
P144	P72	P72	72 - 216	1 - 36	
P168	P96	P72	84 - 252	1 - 42	
P192	P96	P96	96 - 288	1 - 48	
P216	P120	P96	108 - 324	2 - 50	
P240	P120	P120	120 - 360		
P288	P144	P144	144 - 432		
P312	P168	P144	156 - 468		
P336	P168	P168	168 - 504		

Note

- 1) "Maximum total capacity of connectable indoor units" refers to the sum of the numeric values in the indoor unit model names.
- 2) If the total capacity of the indoor units that are connected to a given heat source unit exceeds the capacity of the heat source unit, the indoor units will not be able to perform at the rated capacity when they are operated simultaneously. Select a combination of units so that the total capacity of the connected indoor units is at or below the capacity of the heat source unit whenever possible.

[2] Types and Maximum allowable Length of Cables

1. Wiring work

(1) Notes

- 1) Have all electrical work performed by an authorized electrician according to the local regulations and instructions in this manual.
- 2) Install external transmission cables at least 5cm [1-31/32"] away from the power supply cable to avoid noise interference. (Do not put the control cable and power supply cable in the same conduit tube.)
- 3) Provide grounding for the heat source unit as required.
- 4) Run the cable from the electric box of the indoor or heat source unit in such way that the box is accessible for servicing.
- 5) Do not connect power supply wiring to the terminal block for transmission line. Doing so will damage the electronic components on the terminal block.
- 6) Use 2-core shielded cables as transmission cables.

Use a separate 2-core control cable for each refrigerant system. Do not use a single multiple-core cable to connect indoor units that belong to different refrigerant systems. The use of a multiple-core cable may result in signal transmission errors and malfunctions.

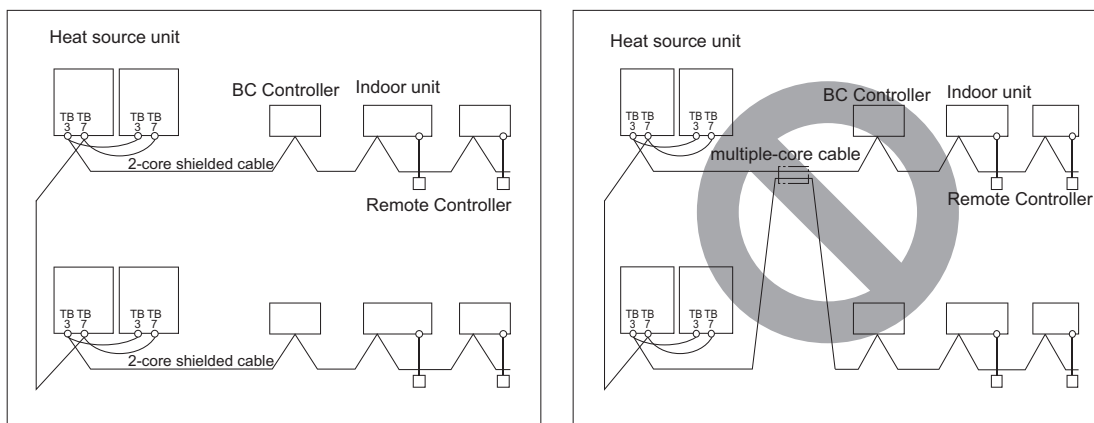

TB3: Terminal block for indoor-heat source transmission line TB7: Terminal block for centralized control

- 7) When extending the transmission cable, be sure to connect the shield.
- 8) When opening or closing the front cover of the control box, keep out of contact with the internal parts. Before inspecting the inside of the control box, turn off the power, leave the unit turned off for at least 10 minutes, and check that the voltage of the electrolytic capacitor (inverter main circuit) has dropped to 20 VDC or less.
- 9) Control boxes house high-voltage and high-temperature electrical parts. Use caution not to come in contact with them.
- 10) When the unit is turned on, the compressor will remain energized even when it is stopped to vaporize the liquid refrigerant that accumulates in the compressor. Disconnect the power supply cable from the compressor terminal block, and measure the insulation resistance of the compressor. Check that the compressor is not ground faulted. If the insulation resistance is 1 MΩ or below, reconnect power supply to the compressor, and turn on the power.
- 11) Read Chapter I [13] Precautions for servicing (page 15), and tighten screws to the appropriate torque. Loose screws and poor contact can result in overheating and fire.

(2) Control wiring

Different types of control wiring are used for different systems.

Refer to section "[5] An Example of a System to which an MA Remote Controller is connected - [7] An Example of a System to which both MA Remote Controller and ME Remote Controller are connected" before performing wiring work.

Types and maximum allowable length of cables

Control lines are categorized into 2 types: transmission line and remote controller line.

Use the appropriate type of cables and observe the maximum allowable length specified for a given system. If a given system has a long transmission line or if a noise source is located near the unit, place the unit away from the noise source to reduce noise interference.

1) M-NET transmission line

Cable type	Facility type	All facility types
	Type	Shielded cable CVVS, CPEVS, MVVS
	Number of cores	2-core cable
	Cable size	Larger than 1.25mm ² [AWG16], or ø1.2mm or above
Maximum transmission line distance between the heat source unit and the farthest indoor unit		200 m [656ft] max.
Maximum transmission line distance for centralized control and Indoor-heat source transmission line (Maximum line distance via heat source unit)		500 m [1640ft] max. *The maximum overall line length from the power supply unit on the transmission lines for centralized control to each heat source unit or to the system controller is 200m [656ft] max.

2) Remote controller wiring

		MA remote controller ^{*1}	ME remote controller ^{*5}
Cable type	Type	VCTF, VCTFK, CVV, CVS, VVR, VVF, VCT	Shielded cable MVVS
	Number of cores	2-core cable	2-core cable
	Cable size	0.3 to 1.25mm ² ^{*2} ^{*4} [AWG22 to 16] (0.75 to 1.25mm ²) ^{*3} [AWG18 to 16]	0.3 to 1.25mm ² ^{*2} [AWG22 to 16] (0.75 to 1.25mm ²) ^{*3} [AWG18 to 16]
Maximum overall line length		200 m [656ft] max.	The section of the cable that exceeds 10m [32ft] must be included in the maximum indoor-heat source transmission line distance.

*1 MA remote controller refers to MA remote controller (PAR-20MAU, PAR-21MAAU, PAR-30MAAU), Simple MA Remote Controller (PAC-YT53CRAU), and wireless remote controller.

*2 The use of cables that are smaller than 0.75mm² (AWG18) is recommended for easy handling.

*3 When connected to the terminal block on the Simple remote controller, use cables that meet the cable size specifications shown in the parenthesis.

*4 When connecting PAR-30MAAU, use a 0.3mm² sheathed cable.

*5 ME remote controller refers to ME remote controller and Simple ME Remote Controller.

[3] Switch Settings and Address Settings

1. Switch setting

Refer to section "[5] An Example of a System to which an MA Remote Controller is connected - [7] An Example of a System to which both MA Remote Controller and ME Remote Controller are connected" before performing wiring work.

Set the switches while the power is turned off.

If the switch settings are changed while the unit is being powered, those changes will not take effect, and the unit will not function properly.

Units on which to set the switches		Symbol	Units to which the power must be shut off
CITY MULTI indoor unit	Main/sub unit	IC	Heat source units ^{*3} and Indoor units
LOSSNAY, OA processing unit ^{*1}		LC	Heat source units ^{*3} and LOSSNAY
M-NET remote controller	Main/sub remote controller	RC	Heat source units ^{*3}
MA remote controller	Main/sub remote controller	MA	Indoor units
CITY MULTI heat source unit ^{*2}		OC,OS	Heat source units ^{*3}
BC controller	Main	BC	Heat source units ^{*3} and BC controller
	Sub1, 2	BS1, BS2	Heat source units ^{*3} ^{*4} and BC controller

*1. Applicable when LOSSNAY units are connected to the indoor-heat source transmission line.

*2. The heat source units in the same refrigerant circuit are automatically designated as OC and OS in the order of capacity from large to small (if two or more units have the same capacity, in the order of address from small to large).

*3. Turn off the power to all the heat source units in the same refrigerant circuit.

*4. When setting the switch SW4 of the control board, set it with the heat source unit power on. Refer to the following page(s). VII [1] Functions and Factory Settings of the Dipswitches(page 159)

2. M-NET Address settings

(1) Address settings table

The need for address settings and the range of address setting depend on the configuration of the system.

Unit or controller		Sym- bol	Address setting range	Setting method	Factory address setting
CITYMULTI indoor unit	Main/sub unit	IC	0, 01 to 50 ^{*1 *4 *6}	Assign the smallest address to the main indoor unit in the group, and assign sequential address numbers to the rest of the indoor units in the same group. In an R2 system with a sub BC controller, make the settings for the indoor units in the following order. (i) Indoor unit to be connected to the main BC controller (ii) Indoor unit to be connected to sub BC controller 1 (iii) Indoor unit to be connected to sub BC controller 2 Make the settings for the indoor units in the way that the formula "(i) < (ii) < (iii)" is true.	00
M-NET adapter					
M-NET control interface					
Free Plan adapter					
LOSSNAY, OA processing unit		LC	0, 01 to 50 ^{*1 *4 *6}	Assign an arbitrary but unique address to each of these units after assigning an address to all indoor units.	00
M-NET remote controller	Main remote controller	RC	101 to 150	Add 100 to the smallest address of all the indoor units in the same group.	101
	Sub remote controller	RC	151 to 200 ^{*3}	Add 150 to the smallest address of all the indoor units in the same group.	
MA remote controller		MA	No address settings required. (The main/sub setting must be made if 2 remote controllers are connected to the system.)		Main
CITY MULTI heat source unit		OC OS	0, 51 to 100 ^{*1 *2 *6}	<ul style="list-style-type: none"> Assign an address that equals the lowest address of the indoor units in the same refrigerant circuit plus 50. Assign sequential addresses to the heat source units in the same refrigerant circuit. The heat source units in the same refrigerant circuit are automatically designated as OC and OS.⁵ 	00
Auxiliary heat source unit	BC controller (main)	BC	0, 51 to 100 ^{*1 *2 *6}	<ul style="list-style-type: none"> Assign an address that equals the address of the heat source unit in the same refrigerant system plus 1. If a given address overlaps any of the addresses that are assigned to the heat source units or to the sub BC controller, use a different, unused address within the setting range. 	00
	BC controller (sub1, 2)	BS1 BS2	51 to 100 ^{*2}	<ul style="list-style-type: none"> Assign an address to both the sub BC controller 1 and 2 that equals the lowest address of the indoor units that are connected to each of them plus 50. If a sub BC controller is connected, the automatic startup function is not available. 	
System controller	Group remote controller	GR SC	201 to 250	Assign an address that equals the sum of the smallest group number of the group to be controlled and 200.	201
	System remote controller	SR SC		Assign an arbitrary but unique address within the range listed on the left to each unit.	
	ON/OFF remote controller	AN SC		Assign an address that equals the sum of the smallest group number of the group to be controlled and 200.	
	Schedule timer (compatible with M-NET)	ST SC	Assign an arbitrary but unique address within the range listed on the left to each unit.	202	
	Central controller AG-150A, G(B)-50A, GB-24A	TR SC	0, 201 to 250	Assign an arbitrary but unique address within the range listed on the left to each unit. The address must be set to "0" to control the K-control unit.	000
	Expansion controller PAC-YG50ECA				
	BM adapter BAC-HD150	SC			
LM adapter	SC	201 to 250	Assign an arbitrary but unique address within the range listed on the left to each unit.	247	

*1. If a given address overlaps any of the addresses that are assigned to other units, use a different, unused address within the setting range.

*2. To set the heat source unit address or the auxiliary heat source unit address to "100," set the rotary switches to "50."

*3. To set the M-NET remote controller address to "200," set the rotary switches to "00."

*4. Some models of indoor units have two or three control boards.

Assign an address to the No. 1, No. 2, and No. 3 control boards so that the No. 2 control board address equals the No. 1 control board address plus 1, and that the No. 3 control board address equals the No. 1 control board address plus 2.

*5. The heat source units in the same refrigerant circuit are automatically designated as OC, and OS. They are designated as OC, and OS in the descending order of capacity (ascending order of address if the capacities are the same).

*6. No address settings are required for units in a system with a single heat source unit (with some exceptions). Address setting is required if a sub BC controller is connected.

(2) Power supply switch connector connection on the heat source unit (Factory setting: The male power supply switch connector is connected to CN41.)

There are limitations on the total number of units that are connectable to each refrigerant system. Refer to the DATABOOK for details.

System configuration	Connection to the system controller	Power supply unit for transmission lines	Group operation of units in a system with multiple heat source units	Power supply switch connector connection
System with one heat source unit	–	–	–	Leave CN41 as it is (Factory setting)
System with multiple heat source units	Not connected	–	Not grouped	Disconnect the male connector from the female power supply switch connector (CN41) and connect it to the female power supply switch connector (CN40) on only one of the heat source units. ^{*2} *Connect the S (shielded) terminal on the terminal block (TB7) on the heat source unit whose CN41 was replaced with CN40 to the ground terminal (r/r) on the electric box.
	With connection to the indoor-heat source transmission line	Not required	Grouped/not grouped	
	With connection to the centralized control system	Not required ^{*1} (Powered from the heat source unit)	Grouped/not grouped	Leave CN41 as it is (Factory setting)
		Required ^{*1}	Grouped/not grouped	

*1 The need for a power supply unit for transmission lines depends on the system configuration.

*2 The replacement of the power jumper connector from CN41 to CN40 must be performed on only one heat source unit in the system.

(3) Settings for the centralized control switch for the heat source unit (Factory setting: SW5-1 are set to OFF.)

System configuration	Centralized control switch settings ^{*1}
Connection to the system controller Not connected	Leave it to OFF. (Factory setting)
Connection to the system controller Connected ^{*2}	ON

*1. Set SW5-1 on all heat source units in the same refrigerant circuit to the same setting.

*2. When only the LM adapter is connected, leave SW5-1 to OFF (as it is).

(4) Selecting the position of temperature detection for the indoor unit (Factory setting: SW1-1 set to "OFF".)

To stop the fan during heating Thermo-OFF (SW1-7 and 1-8 on the indoor units to be set to ON), use the built-in thermistor on the remote controller or an optional thermistor.

1) To use the built-in sensor on the remote controller, set the SW1-1 to ON.

♦Some models of remote controllers are not equipped with a built-in temperature sensor. Use the built-in temperature sensor on the indoor unit instead.

♦When using the built-in sensor on the remote controller, install the remote controller where room temperature can be detected. (Note) Factory setting for SW1-1 on the indoor unit of the All-Fresh Models is ON.

2) When an optional temperature sensor is used, set SW1-1 to OFF, and set SW3-8 to ON.

♦When using an optional temperature sensor, install it where room temperature can be detected.

(5) Various start-stop controls (Indoor unit settings)

Each indoor unit (or group of indoor units) can be controlled individually by setting SW 1-9 and 1-10.

Function	Operation of the indoor unit when the operation is resumed after the unit was stopped	Setting (SW1) ^{*4 *5}	
		9	10
Power ON/OFF by the plug ^{*1,*2,*3}	Indoor unit will go into operation regardless of its operation status before power off (power failure). (In approx. 5 minutes)	OFF	ON
Automatic restoration after power failure	Indoor unit will go into operation if it was in operation when the power was turned off (or cut off due to power failure). (In approx. 5 minutes)	ON	OFF
	Indoor unit will remain stopped regardless of its operation status before power off (power failure).	OFF	ON

*1. Do not cut off power to the heat source unit. Cutting off the power supply to the heat source unit will cut off the power supply to the crankcase heater and may cause the compressor to malfunction when the unit is put back into operation.

*2. Not applicable to units with a built-in drain pump or humidifier.

*3. Models with a built-in drain pump cannot be turned on/off by the plug individually. All the units in the same refrigerant circuits will be turned on or off by the plug.

*4. Requires that the dipswitch settings for all the units in the group be made.

*5. Set SW1-9 and SW1-10 to ON to control the external input from/output to the air conditioning units via AG-150A or G(B)-50A using the PLC software for general equipment. With these settings made, the power start-stop function becomes disabled. To use the auto recovery function after power failure while these settings are made, set SW1-5 to ON.

(6) Miscellaneous settings

Cooling-only setting for the indoor unit: Cooling only model (Factory setting: SW3-1 "OFF.")

When using indoor unit as a cooling-only unit, set SW3-1 to ON.

(7) Various types of control using input-output signal connector on the heat source unit (various connection options)

Type	Usage	Function	Terminal ^{*1} to be used	Option
Input	Prohibiting cooling/heating operation (thermo OFF) by an external input to the heat source unit. * Usable for demand control of each refrigerant system	DEMAND (level)	CN3D ^{*2}	Adapter for external input (PAC-SC36NA-E)
	Performs a low level noise operation of the heat source unit by an external input to the heat source unit. * It can be used as the silent operation device for each refrigerant system.	Low-noise mode (level) ^{*3 *4}		
	Cooling/heating operation can be changed by an external input to the heat source unit (OC).	Auto-changeover	CN3N	
	Receives interlock operation signal input from the water circuit pump (field-supplied)	Pump interlock operation signal input	TB-8 (between poles 3 and 4) *Minimum guaranteed current at no-voltage input contact: 5 mA or below	—
Out-put	Outputs signals to perform interlocked operation of heat source unit and water circuit pump Signal output patterns *When DIP SW4 No.917 (SW6-10: ON) is set to off (factory setting) Signals are output while the compressor is in operation. *When DIP SW4 No.917 (SW6-10: ON) is set to ON Signals are output while receiving cooling or heating signal from the controller. *Signals are output even if the thermostat is OFF. (when the compressor is not operating)	Pump interlock operation signal	TB-8 (between poles 1 and 2) *Contact rating: 208/230VAC 1A or below	—
	How to extract signals from the heat source unit *It can be used as an operation status display device. *It can be used for an interlock operation with external devices.	Operation status of the compressor Error status	CN51	Adapter for external output (PAC-SC37SA-E)

*1. For detailed drawing, refer to "Example of wiring connection".

*2. For details, refer to the next section "Demand control".

- *3. Low-noise mode is valid when Dip SW6-8 on the heat source unit is set to OFF. When DIP SW6-8 is set to ON, 4 levels of on-DEMAND are possible, using different configurations of low-noise mode input and DEMAND input settings. When 2 or more heat source units exist in one refrigerant circuit system, 8 levels of on-DEMAND are possible. When 3 heat source units exist in one refrigerant circuit system, 12 levels of on-DEMAND are possible.
- *4. By setting Dip SW6-7, the Low-noise mode can be switched between the Capacity priority mode and the Low-noise priority mode.
 When SW6-7 is set to ON: The low-noise mode always remains effective.
 When SW6-7 is set to OFF: The low noise mode is cancelled when certain operation pressure criteria are met, and the unit goes into normal operation (capacity priority mode).

Low-noise mod is effective.		Capacity priority mode becomes effective.	
Cooling	Heating	Cooling	Heating
63HS1<32kg/cm ²	63LS>4.6kg/cm ²	63HS1>35kg/cm ²	63LS<3.9kg/cm ²

- *5. When multiple heat source units exist in one refrigerant circuit system, settings on every heat source unit (signal input) are required.

CAUTION

- 1) Wiring should be covered by insulation tube with supplementary insulation.
- 2) Use relays or switches with IEC or equivalent standard.
- 3) The electric strength between accessible parts and control circuit should have 2750V or more.

Example of wiring connection

(1) CN51

Preparations in the field Maximum cable length is 10m

L1 : Heat source unit error display lamp
 L2 : Compressor operation lamp (compressor running state)
 X, Y : Relay (coil =<0.9W : DC12V)
 *1: Optional part : PAC-SC37SA-E or field supply.

(2) CN3N

		X	
		OFF	ON
Y	OFF	Normal	
	ON	Cooling	Heating

Preparations in the field Maximum cable length is 10m

X : Cooling / Heating
 Y : Validity / Invalidity of X
 X, Y : Relay Contact rating voltage >= DC15V
 Contact rating current >= 0.1A
 Minimum applicable load =< 1mA at DC
 *2: Optional part : PAC-SC36NA-E or field supply.

(3) CN3D

Preparations in the field Maximum cable length is 10m

X : Low-noise mode
 Y : Compressor ON/OFF
 X, Y : Relay Contact rating voltage >= DC15V
 Contact rating current >= 0.1A
 Minimum applicable load =< 1mA at DC
 *2: Optional part : PAC-SC36NA-E or field supply.

Preparations in the field Maximum cable length is 10m

X : Low-noise mode
 X : Relay Contact rating voltage >= DC15V
 Contact rating current >= 0.1A
 Minimum applicable load =< 1mA at DC
 *2: Optional part : PAC-SC36NA-E or field supply.
 Low-noise mode : The noise level is reduced by controlling the maximum fan frequency and maximum compressor frequency.

(4) TB8

When connecting the pump interlock circuit wires to terminals 3 and 4 of TB8, remove the short-circuit wire.
 63PW: Pressure switch (Contact: Minimum applied load 5 mA)
 Use an insulated ring terminal for the cable that connects to TB8.
 Be sure to switch off the power source before performing work. (A voltage of 208/230 is present across terminals 3 and 4 on TB8 when power is supplied.)

X: Relay (Contact rating: 208/230VAC 1A)
 52P: Pump contactor

(8) Demand control

1) General outline of control

Demand control is performed by using the external signal input to the 1-2 and 1-3 pins of CN3D on the heat source units (OC and OS).

Between 2 and 12 steps of demand control is possible by setting DIP SW6-8 on the heat source units (OC and OS).

Table.1

No	Demand control switch	DipSW6-8		Input to CN3D *2
		OC	OS	
(a)	2 steps(0-100%)	OFF	OFF	OC
(b)	4 steps(0-50-75-100%)	ON	OFF	OC
(c)		OFF	ON	OS
(d)	8 steps(0-25-38-50-63-75-88-100%)	ON	ON	OC and OS

*1. Available demand functions

P72-P240TLMU/YLMU models (single-heat source-unit system): 2 and 4 steps shown in the rows (a) and (b) in the table above only.

P144-P360TLMU/YLMU models (two-heat source-unit system OC+OS): 2-8 steps shown in the rows (a), (b), (c), and (d) in the table above only.

*2. External signal is input to CN3D on the heat source unit whose SW6-8 is set to ON. When SW6-8 is set to OFF on all heat source units, the signal is input to the CN3D on the OC.

Heat source units whose SW6-8 is set to ON are selectable in a single refrigerant system.

*3. If wrong sequence of steps are taken, the units may go into the Thermo-OFF (compressor stop) mode.

Ex) When switching from 100% to 50%

(Incorrect) 100% to 0% to 50% : The units may go into the Thermo-OFF mode.

(Correct) 100% to 75% to 50%

*4. The percentage of the demand listed in the table above is an approximate value based on the compressor volume and does not necessarily correspond with the actual capacity.

*5. Notes on using demand control in combination with the low-noise mode

To enable the low-noise mode, it is necessary to short-circuit 1-2 pin of CN3D on the heat source unit whose SW6-8 is set to OFF.

When SW6-8 is set to ON on all heat source units, the following operations cannot be performed.

- Performing 4-step demand in combination with the low-noise operation in a single-heat source-unit system.
- Performing 8-step demand in combination with the low-noise operation in a two-heat source-unit system.
- Performing 12-step demand in combination with the low-noise operation in a three-heat source-unit system.

2) Contact input and control content

2-step demand control

The same control as the Thermo-OFF is performed by closing 1-3 pin of CN3D.

CN3D	
1-3P	
Open	x = 100%
Close	x = 0%

4-step demand control (When SW6-8 is set to ON on an heat source unit)

Demand capacity is shown below.

CN3D	1-2P	
	Open	Close
Open	100%	75%
Close	0%	50%

8-step demand control (When SW6-8 is set to ON on two heat source units)

Demand capacity is shown below.

8-step demand		No.2 CN3D				
		1-2P	Open		Short-circuit	
No.1 CN3D	1-2P	1-3P	Open	Short-circuit	Open	Short-circuit
	Open	Open	100%	50%	88%	75%
		Short-circuit	50%	0%	38%	25%
	Short-circuit	Open	88%	38%	75%	63%
Short-circuit		75%	25%	63%	50%	

*1. The heat source units whose SW6-8 is set to ON are designated as No. 1 and No. 2 in the order of address from small to large.

Ex) When heat source units whose SW6-8 is set to ON are designated as OC and OS, OC = No. 1 and OS = No. 2.

[4] Sample System Connection

Examples of typical system connection are shown on pages [5] to [7].
Refer to the Installation Manual that came with each device or controller for details.

(1) An example of a system to which an MA remote controller is connected

	System configuration	Connection to the system controller	Address start up for indoor and heat source units	Notes
1	System with one heat source unit	NO	Automatic address setup	
2	System with one heat source unit	NO	Manual address setup	Connection of multiple LOSS-NAY units
3	Grouping of units in a system with multiple heat source units	NO	Manual address setup	
4	System with one heat source unit	With connection to transmission line for centralized control	Manual address setup	
5	System with one heat source unit	With connection to indoor-heat source transmission line	Manual address setup	
6	System with one heat source unit	With connection to transmission line for centralized control	Manual address setup	Connection of multiple LOSS-NAY units

(2) An example of a system to which an ME remote controller is connected

	System configuration	Connection to the system controller	Address start up for indoor and heat source units	Notes
1	System with one heat source unit	With connection to transmission line for centralized control	Manual address setup	

(3) An example of a system to which both MA remote controller and ME remote controller are connected

	System configuration	Connection to the system controller	Address start up for indoor and heat source units	Notes
1	System with one heat source unit	With connection to transmission line for centralized control	Manual address setup	

*MA remote controller and ME remote controller cannot both be connected to the same group.

[5] An Example of a System to which an MA Remote Controller is connected

1. System with one heat source unit (automatic address setup for both indoor and heat source units) <PQHY>

(1) Sample control wiring

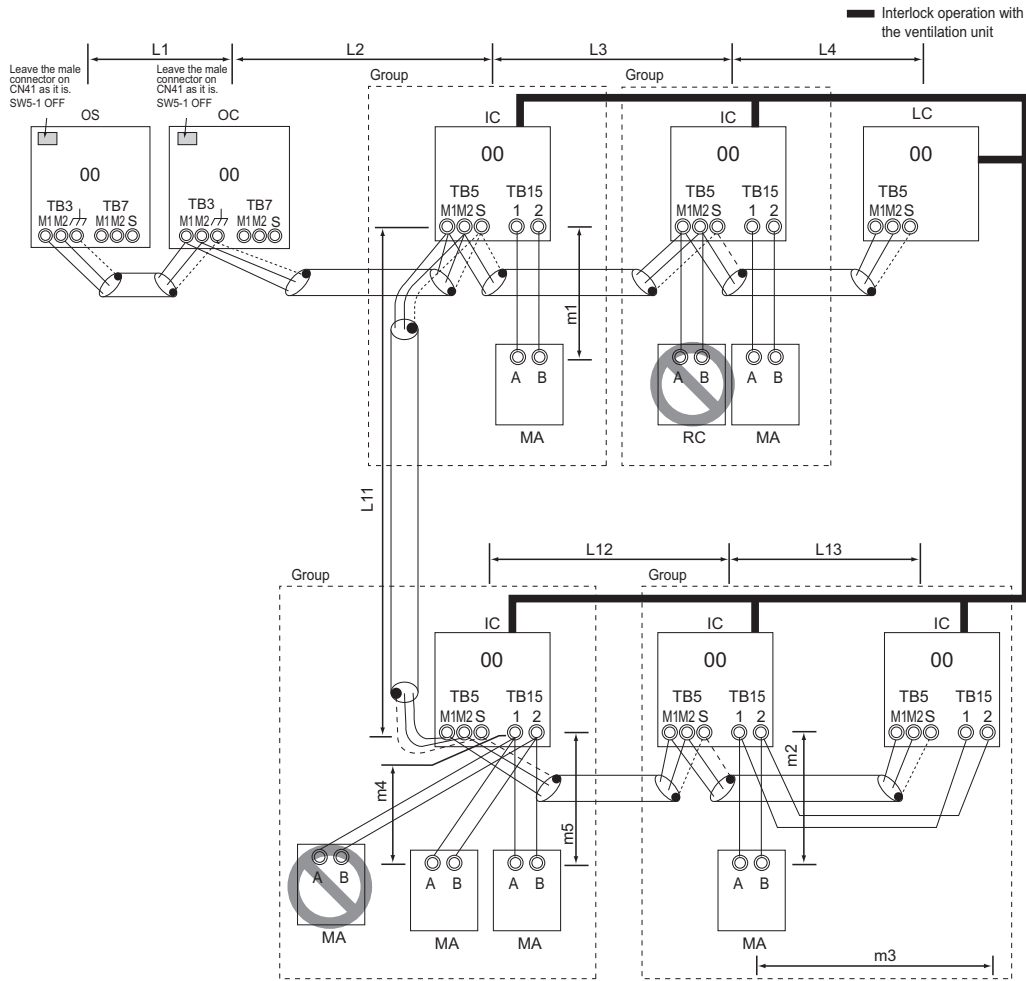

(2) Cautions

- 1) ME remote controller and MA remote controller cannot both be connected to the same group of indoor units.
- 2) No more than 2 MA remote controllers can be connected to a group of indoor units.
- 3) A transmission booster is required in a system to which more than 32 indoor units (26 units if one or more indoor units of the 72 model or above is connected) are connected.
- 4) Automatic address setup is not available if start-stop input (CN32, CN51, CN41) is used for a group operation of indoor units. Refer to "[5] 2. Manual address setup for both indoor and heat source units".(page 32)
- 5) To connect more than 2 LOSSNAY units to indoor units in the same system, refer to the next section "[5] 2. An example of a system with one heat source unit to which 2 or more LOSSNAY units are connected".(page 32)

(3) Maximum allowable length

- 1) Indoor-heat source transmission line
 Maximum distance (1.25mm² [AWG16] or larger)
 $L1 + L2 + L3 + L4 \leq 200m [656ft]$
 $L1 + L2 + L11 + L12 + L13 \leq 200m [656ft]$
- 2) Transmission line for centralized control
 No connection is required.
- 3) MA remote controller wiring
 Maximum overall line length (0.3 to 1.25mm² [AWG22 to 16])
 $m1 \leq 200m [656ft]$
 $m2 + m3 \leq 200m [656ft]$
 $m4 + m5 \leq 200m [656ft]$

(4) Wiring method

1) Indoor-heat source transmission line

Daisy-chain terminals M1 and M2 on the terminal block for indoor-heat source transmission line (TB3) on the heat source units (OC, OS) (Note 1), and terminals M1 and M2 on the terminal block for indoor-heat source transmission line (TB5) on each indoor unit (IC). (Non-polarized two-wire)

•Only use shielded cables.

Note

- a) The heat source units in the same refrigerant circuit are automatically designated as OC and OS in the order of capacity from large to small (if two or more units have the same capacity, in the order of address from small to large).

Shielded cable connection

Daisy-chain the ground terminal (G) on the heat source units (OC, OS), and the S terminal on the terminal block (TB5) on the indoor unit (IC) with the shield wire of the shielded cable.

2) Transmission line for centralized control

No connection is required.

3) MA remote controller wiring

Connect terminals 1 and 2 on the terminal block for MA remote controller line (TB15) on the indoor unit (IC) to the terminal block on the MA remote controller (MA). (Non-polarized two-wire)

When 2 remote controllers are connected to the system

When 2 remote controllers are connected to the system, connect terminals 1 and 2 of the terminal block (TB15) on the indoor unit (IC) to the terminal block on the two MA remote controllers.

•Set one of the MA remote controllers to sub. (Refer to MA remote controller function selection or the installation manual for the MA remote controller for the setting method.)

Group operation of indoor units

To perform a group operation of indoor units (IC), daisy-chain terminals 1 and 2 on the terminal block (TB15) on all indoor units (IC) in the same group, and then connect terminals 1 and 2 on the terminal block (TB15) on the indoor unit on one end to the terminal block on the MA remote controller. (Non-polarized two-wire)

•When performing a group operation of indoor units that have different functions, "Automatic indoor-heat source address setup" is not available.

4) LOSSNAY connection

Connect terminals M1 and M2 on the terminal block (TB5) on the indoor unit (IC) to the appropriate terminals on the terminal block (TB5) on LOSSNAY (LC). (Non-polarized two-wire)

•Interlock operation setting with all the indoor units in the same system will automatically be made. (It is required that the Lossnay unit be turned on before the heat source unit.)

•Refer to "[5] 2. Manual address setup for both indoor and heat source units" in the following cases: performing an interlock operation of part of the indoor units in the system with a LOSSNAY unit, using LOSSNAY alone without interlocking it with any units, performing an interlock operation of more than 16 indoor units with a LOSSNAY unit, or connecting two or more LOSSNAY units to indoor units in the same system.

5) Switch setting

No address settings required.

(5) Address setting method

Procedures	Unit or controller			Address setting range	Setting method	Notes	Factory setting
1	Indoor unit	Main unit	IC	No settings required.	-	To perform a group operation of indoor units that have different functions, refer to [5] 2.(page 32)	00
		Sub unit	IC				
2	LOSSNAY			LC	No settings required.	-	00
3	MA remote controller	Main remote controller	MA	No settings required.	-		Main
		Sub remote controller	MA	Sub remote controller	Settings to be made according to the remote controller function selection		
4	Heat source unit (Note)		OC OS	No settings required.	-		00

Note

The heat source units in the same refrigerant circuit are automatically designated as OC and OS. The heat source units are designated as OC and OS in the order of capacity from large to small (if two or more units have the same capacity, in the order of address from small to large).

2. An example of a system with one heat source unit to which 2 or more LOSSNAY units are connected (manual address setup for both indoor and heat source units) <PQHY>

(1) Sample control wiring

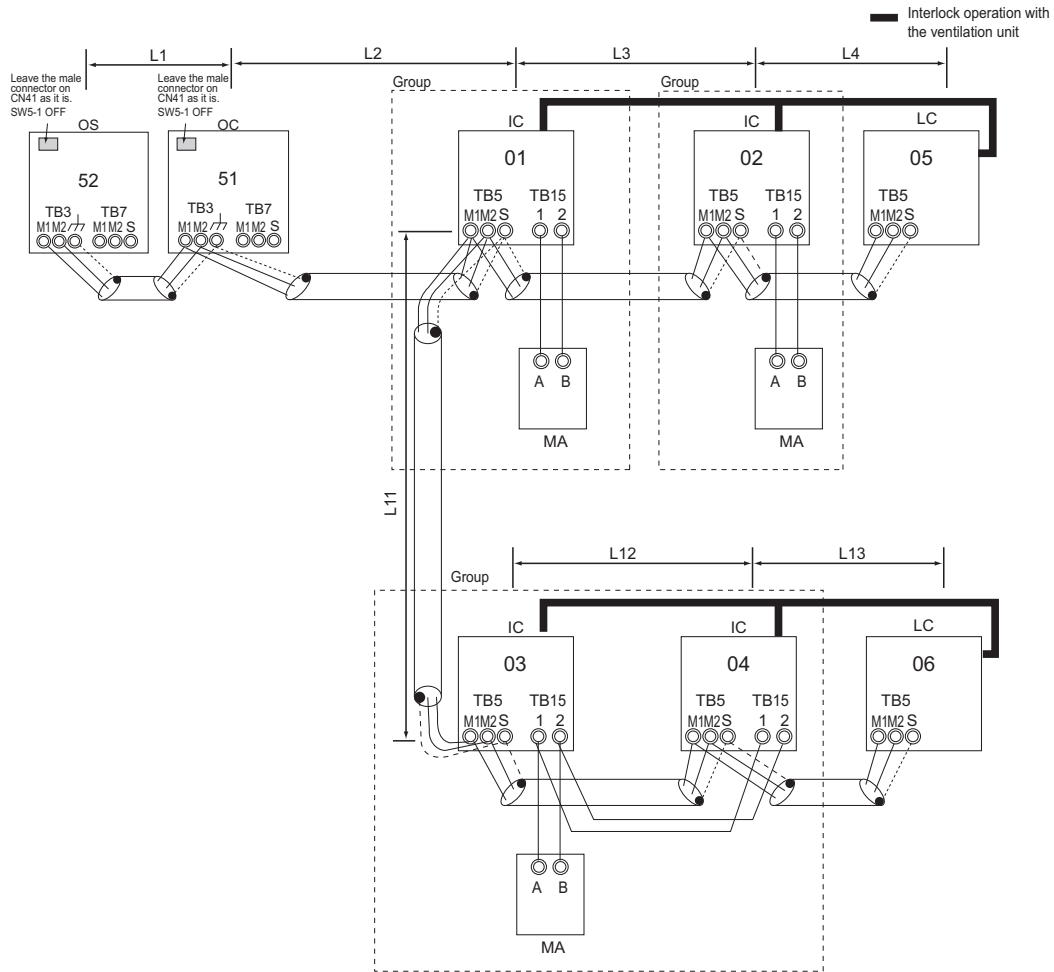

(2) Cautions

- 1) ME remote controller and MA remote controller cannot both be connected to the same group of indoor units.
- 2) No more than 2 MA remote controllers can be connected to a group of indoor units.
- 3) A transmission booster is required in a system to which more than 32 indoor units (26 units if one or more indoor units of the 72 model or above is connected) are connected.

(3) Maximum allowable length

- 1) Indoor-heat source transmission line
Same as [5] 1.
- 2) Transmission line for centralized control
No connection is required.
- 3) MA remote controller wiring
Same as [5] 1.

(4) Wiring method

- 1) Indoor-heat source transmission line

Same as [5] 1.

Shielded cable connection

Same as [5] 1.

- 2) Transmission line for centralized control

No connection is required.

- 3) MA remote controller wiring

Same as [5] 1.

When 2 remote controllers are connected to the system

Same as [5] 1.

Group operation of indoor units

Same as [5] 1.

(5) Address setting method

- 4) LOSSNAY connection

Connect terminals M1 and M2 on the terminal block (TB5) on the indoor unit (IC) to the appropriate terminals on the terminal block (TB5) on LOSSNAY (LC). (Non-polarized two-wire)

•Interlock setting between the indoor units and LOSSNAY units must be entered on the remote controller. (Refer to "IV [3] Interlock Settings via the MA Remote Controller" or the installation manual for the MA remote controller for the setting method.)

- 5) Switch setting

Address setting is required as follows.

Procedures	Unit or controller			Address setting range	Setting method	Notes	Factory setting
1	Indoor unit	Main unit	IC	01 to 50	Assign the smallest address to the main unit in the group.	To perform a group operation of indoor units that have different functions, designate the indoor unit in the group with the greatest number of functions as the main unit.	00
		Sub unit			Assign sequential numbers starting with the address of the main unit in the same group +1. (Main unit address +1, main unit address +2, main unit address +3, etc.)		
2	LOSSNAY		LC	01 to 50	Assign an arbitrary but unique address to each of these units after assigning an address to all indoor units.	None of these addresses may overlap any of the indoor unit addresses.	00
3	MA remote controller	Main remote controller	MA	No settings required.	-		Main
		Sub remote controller	MA	Sub remote controller	Settings to be made according to the remote controller function selection		
4	Heat source unit		OC OS	51 to 100	Assign sequential address to the heat source units in the same refrigerant circuit. The heat source units are automatically designated as OC and OS.(Note)	To set the address to 100, set the rotary switches to 50.	00

Note

The heat source units in the same refrigerant circuit are automatically designated as OC and OS.

The heat source units are designated as OC and OS in the order of capacity from large to small (if two or more units have the same capacity, in the order of address from small to large).

3. Group operation of units in a system with multiple heat source units <PQHY>

(1) Sample control wiring

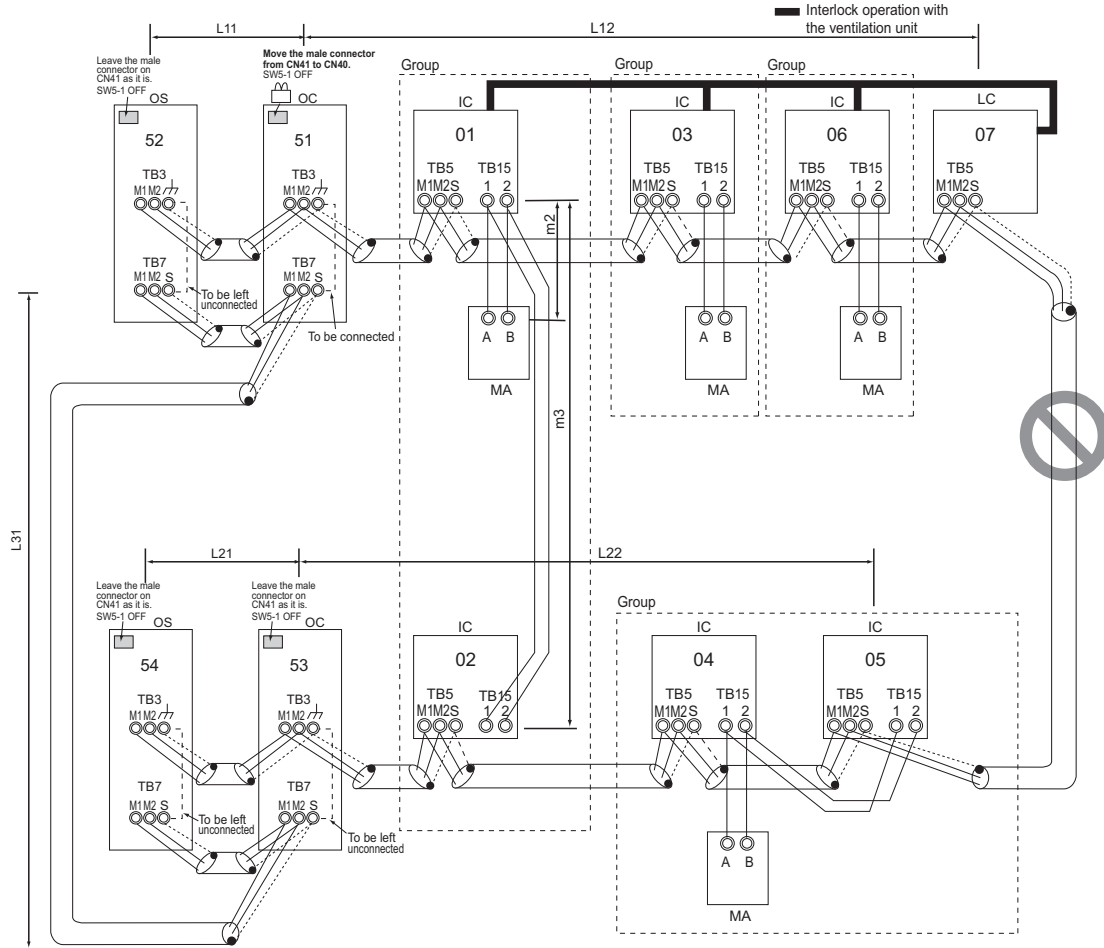

(2) Cautions

- 1) ME remote controller and MA remote controller cannot both be connected to the same group of indoor units.
- 2) No more than 2 MA remote controllers can be connected to a group of indoor units.
- 3) Do not connect the terminal blocks (TB5) on the indoor units that are connected to different heat source units with each other.
- 4) Replacement of male power jumper connector (CN41) must be performed only on one of the heat source units.
- 5) Provide grounding to S terminal on the terminal block for transmission line for centralized control (TB7) on only one of the heat source units.
- 6) A transmission booster is required in a system to which more than 32 indoor units (26 units if one or more indoor units of the 72 model or above is connected) are connected.

♦Refer to the DATABOOK for further information about how many booster units are required for a given system.

(3) Maximum allowable length

- 1) Indoor-heat source transmission line
 Maximum distance (1.25mm² [AWG16] or larger)
 $L11+L12 \leq 200\text{m}$ [656ft]
 $L21+L22 \leq 200\text{m}$ [656ft]
- 2) Transmission line for centralized control
 $L31+L21 \leq 200\text{m}$ [656ft]
- 3) MA remote controller wiring
 Same as [5] 1.
- 4) Maximum line distance via heat source unit
 (1.25mm² [AWG16] or larger)
 $L12+L31+L22 \leq 500\text{m}$ [1640ft]
 $L11+L31+L21 \leq 500\text{m}$ [1640ft]

(4) Wiring method

- 1) Indoor-heat source transmission line

Same as [5] 1.

•Only use shielded cables.

Shielded cable connection

Same as [5] 1.

- 2) Transmission line for centralized control

Daisy-chain terminals M1 and M2 on the terminal block for transmission line for centralized control (TB7) on the heat source units (OC) in different refrigerant circuits and on the OC and OS in the same refrigerant circuit.

If a power supply unit is not connected to the transmission line for centralized control, replace the power jumper connector on the control board from CN41 to CN40 on only one of the heat source units.

whose power jumper was moved from CN41 to CN40, central control is not possible, even if TB7's are daisy-chained.)

•Only use shielded cables.

Shielded cable connection

Daisy-chain the S terminal on the terminal block (TB7) on the heat source units (OC, OS) with the shield wire of the shielded cable. Short-circuit the earth terminal (r) and the S terminal on the terminal block (TB7) on the heat source unit whose power jumper connector is mated with CN40.

- 3) MA remote controller wiring

Same as [5] 1.

When 2 remote controllers are connected to the system

Same as [5] 1.

Group operation of indoor units

Same as [5] 2.

- 4) LOSSNAY connection

Same as [5] 2.

- 5) Switch setting

Address setting is required as follows.

Note

- a) The heat source units in the same refrigerant circuit are automatically designated as OC and OS in the order of capacity from large to small (if two or more units have the same capacity, in the order of address from small to large).
- b) If TB7's on the heat source units in the same refrigerant circuit are not daisy-chained, connect the transmission line for the central control system to TB7 of the OC. (Note a).To maintain the central control even during an OC failure or a power failure, connect TB7 on OC and OS together. (If there is a problem with the heat source unit

(5) Address setting method

Procedures	Unit or controller			Address setting range	Setting method	Notes	Factory setting
1	Indoor unit	Main unit	IC	01 to 50	Assign the smallest address to the main unit in the group.	To perform a group operation of indoor units that have different functions, designate the indoor unit in the group with the greatest number of functions as the main unit.	00
		Sub unit			Assign sequential numbers starting with the address of the main unit in the same group +1. (Main unit address +1, main unit address +2, main unit address +3, etc.)		
2	LOSSNAY		LC	01 to 50	Assign an arbitrary but unique address to each of these units after assigning an address to all indoor units.	None of these addresses may overlap any of the indoor unit addresses.	00
3	MA remote controller	Main remote controller	MA	No settings required.	-		Main
		Sub remote controller	MA	Sub remote controller	Settings to be made according to the remote controller function selection		
4	Heat source unit		OC OS	51 to 100	Assign sequential address to the heat source units in the same refrigerant circuit. The heat source units are automatically designated as OC and OS. (Note)	To set the address to 100, set the rotary switches to 50.	00

Note

The heat source units in the same refrigerant circuit are automatically designated as OC and OS. The heat source units are designated as OC and OS in the order of capacity from large to small (if two or more units have the same capacity, in the order of address from small to large).

4. A system in which a system controller is connected to the transmission line for centralized control and which is powered from a heat source unit <PQHY>

(1) Sample control wiring

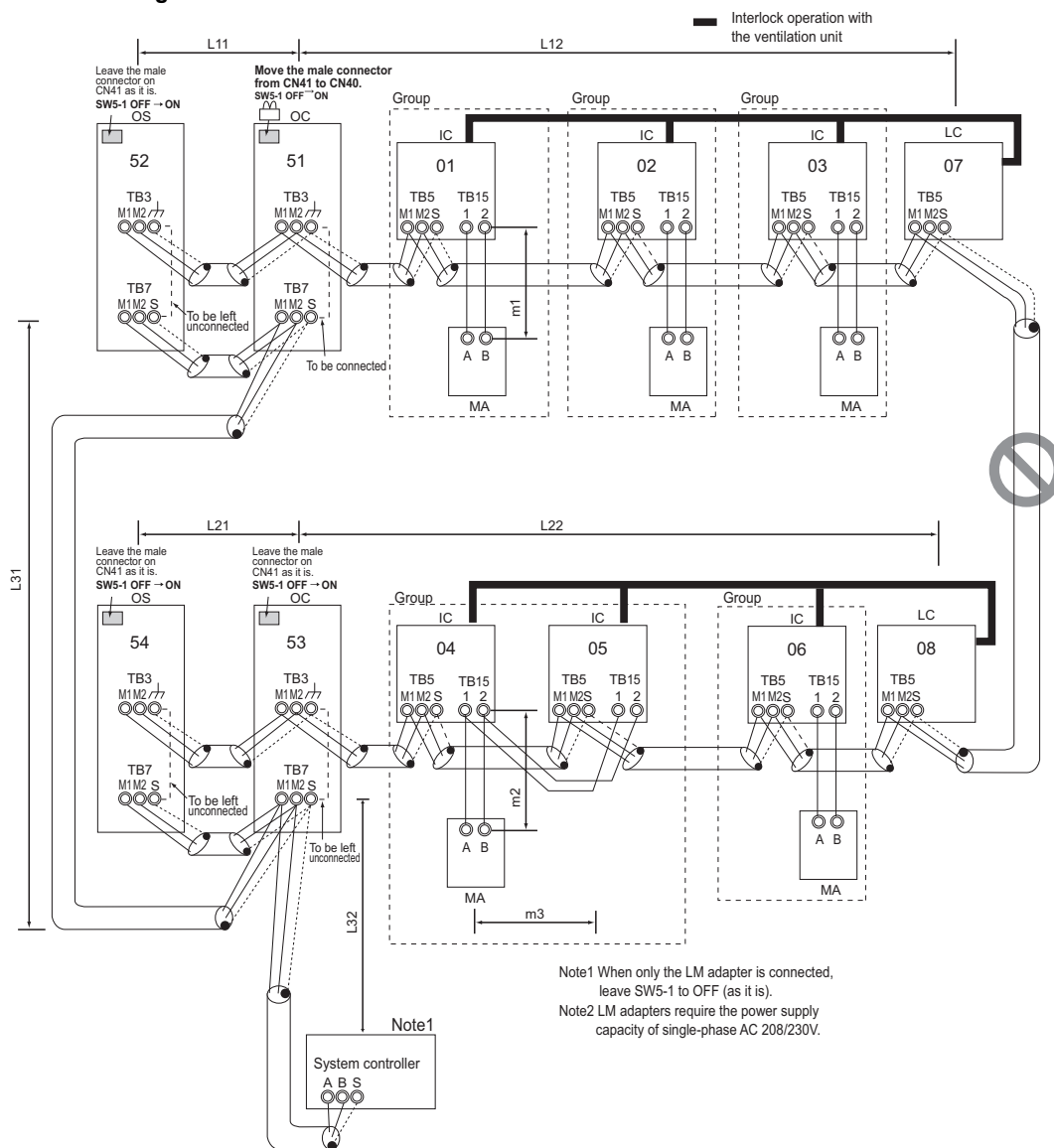

(2) Cautions

- 1) ME remote controller and MA remote controller cannot both be connected to the same group of indoor units.
- 2) No more than 2 MA remote controllers can be connected to a group of indoor units.
- 3) Do not connect the terminal blocks (TB5) on the indoor units that are connected to different heat source units with each other.
- 4) Replacement of male power jumper connector (CN41) must be performed only on one of the heat source units.
- 5) Short-circuit the shield terminal (S terminal) and the earth terminal (⌚) on the terminal block for transmission line for centralized control (TB7) on the heat source unit whose power jumper connector is mated with CN40.
- 6) A transmission booster is required in a system to which more than 32 indoor units (26 units if one or more indoor units of the 72 model or above is connected) are connected.
- 7) When a power supply unit is connected to the transmission line for centralized control, leave the power jumper connector on CN41 as it is (factory setting).
 - ♦Refer to the DATABOOK for further information about how many booster units are required for a given system.

(3) Maximum allowable length

- 1) Indoor-heat source transmission line
Same as [5] 3.
- 2) Transmission line for centralized control
 $L31+L32(L21) \leq 200\text{m}$ [656ft]
- 3) MA remote controller wiring
Same as [5] 1.
- 4) Maximum line distance via heat source unit
(1.25mm² [AWG16] or larger)
 $L32+L31+L12(L11) \leq 500\text{m}$ [1640ft]
 $L32+L22(L21) \leq 500\text{m}$ [1640ft]
 $L12(L11)+L31+L22(L21) \leq 500\text{m}$ [1640ft]

(4) Wiring method

- 1) Indoor-heat source transmission line
Same as [5] 1.
Only use shielded cables.
Shielded cable connection
Same as [5] 1.
- 2) Transmission line for centralized control
Daisy-chain terminals A and B on the system controller, terminals M1 and M2 on the terminal block for transmission line for centralized control (TB7) on the heat source units (OC) in different refrigerant circuits and on the heat source units (OC and OS) in the same refrigerant circuit.
If a power supply unit is not connected to the transmission line for centralized control, replace the power jumper connector on the control board from CN41 to CN40 on only one of the heat source units.
If a system controller is connected, set the central control switch (SW5-1) on the control board of all heat source units to "ON."

Note

- a) The heat source units in the same refrigerant circuit are automatically designated as OC and OS in the order of capacity from large to small (if two or more units have the same capacity, in the order of address from small to large).
- b) If TB7's on the heat source units in the same refrigerant circuit are not daisy-chained, connect the transmission line for the central control system to TB7 of the OC. (Note a). To maintain the central control even during an OC failure or a power failure, connect TB7 on OC and OS together. (If there is a problem with the heat source unit whose power jumper

(5) Address setting method

was moved from CN41 to CN40, central control is not possible, even if TB7's are daisy-chained.)

•Only use shielded cables.

Shielded cable connection

Daisy-chain the S terminal on the terminal block (TB7) on the heat source units (OC, OS) with the shield wire of the shielded cable. Short-circuit the earth terminal (\oplus) and the S terminal on the terminal block (TB7) on the heat source unit whose power jumper connector is mated with CN40.

- 3) MA remote controller wiring

Same as [5] 1.

When 2 remote controllers are connected to the system

Same as [5] 1.

Group operation of indoor units

Same as [5] 1.

- 4) LOSSNAY connection

Connect terminals M1 and M2 on the terminal block (TB5) on the indoor unit (IC) to the appropriate terminals on the terminal block for indoor-heat source transmission line (TB5) on LOSSNAY (LC). (Non-polarized 2-core cable)

•Indoor units must be interlocked with the LOSSNAY unit using the system controller. (Refer to the operation manual for the system controller for the setting method.) Interlock setting from the remote controller is required if the ON/OFF remote controller alone or the LM adapter alone is connected.

- 5) Switch setting

Address setting is required as follows.

Procedures	Unit or controller			Address setting range	Setting method	Notes	Factory setting
1	Indoor unit	Main unit	IC	01 to 50	Assign the smallest address to the main unit in the group.	To perform a group operation of indoor units that have different functions, designate the indoor unit in the group with the greatest number of functions as the main unit.	00
		Sub unit			Assign sequential numbers starting with the address of the main unit in the same group +1. (Main unit address +1, main unit address +2, main unit address +3, etc.)		
2	LOSSNAY		LC	01 to 50	Assign an arbitrary but unique address to each of these units after assigning an address to all indoor units.	None of these addresses may overlap any of the indoor unit addresses.	00
3	MA remote controller	Main remote controller	MA	No settings required.	-	Enter the same indoor unit group settings on the system controller as the ones that were entered on the MA remote controller.	Main
		Sub remote controller	MA	Sub remote controller	Settings to be made according to the remote controller function selection		
4	Heat source unit		OC OS	51 to 100	Assign sequential address to the heat source units in the same refrigerant circuit. The heat source units are automatically designated as OC and OS.(Note)	To set the address to 100, set the rotary switches to 50.	00

Note

The heat source units in the same refrigerant circuit are automatically designated as OC and OS.
The heat source units are designated as OC and OS in the order of capacity from large to small (if two or more units have the same capacity, in the order of address from small to large).

5. An example of a system in which a system controller is connected to the indoor-heat source transmission line (except LM adapter) <PQHY>

(1) Sample control wiring

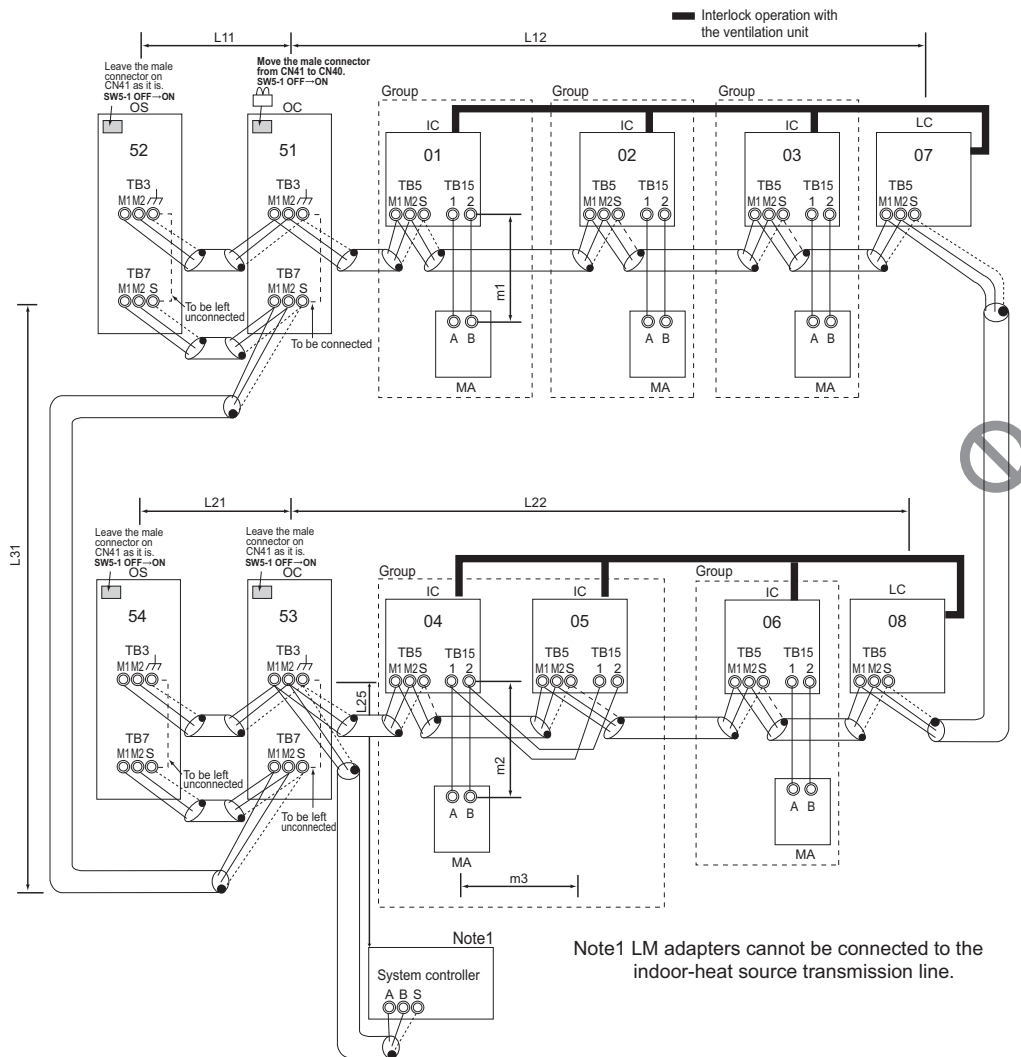

(2) Cautions

- 1) ME remote controller and MA remote controller cannot both be connected to the same group of indoor units.
- 2) No more than 2 MA remote controllers can be connected to a group of indoor units.
- 3) Do not connect the terminal blocks (TB5) on the indoor units that are connected to different heat source units with each other.
- 4) Replacement of male power jumper connector (CN41) must be performed only on one of the heat source units.
- 5) Provide grounding to S terminal on the terminal block for transmission line for centralized control (TB7) on only one of the heat source units.
- 6) A maximum of 3 system controllers can be connected to the indoor-heat source transmission line, with the exception that only one G(B)-50A may be connected.
- 7) When the total number of indoor units exceeds 26, it may not be possible to connect a system controller on the indoor-heat source transmission line.
- 8) In a system to which more than 18 indoor units including one or more indoor units of 72 model or above are connected, there may be cases in which the system controller cannot be connected to the indoor-heat source transmission line.

◆Refer to the DATABOOK for further information about how many booster units are required for a given system.

(3) Maximum allowable length

- 1) Indoor-heat source transmission line
 Maximum distance (1.25mm² [AWG16] or larger)
 $L11+L12 \leq 200\text{m}$ [656ft]
 $L21+L22 \leq 200\text{m}$ [656ft]
 $L25 \leq 200\text{m}$ [656ft]
- 2) Transmission line for centralized control
 $L31+L21 \leq 200\text{m}$ [656ft]
- 3) MA remote controller wiring
 Same as [5] 1.
- 4) Maximum line distance via heat source unit (1.25mm² [AWG16] or larger)
 $L25+L31+L12(L11) \leq 500\text{m}$ [1640ft]
 $L12(L11)+L31+L22(L21) \leq 500\text{m}$ [1640ft]
 $L25+L22(L21) \leq 500\text{m}$ [1640ft]

(4) Wiring method

1) Indoor-heat source transmission line

Daisy-chain terminals M1 and M2 on the terminal block for indoor-heat source transmission line (TB3) on the heat source units (OC, OS) (Note 1), terminals M1 and M2 on the terminal block for indoor-heat source transmission line (TB5) on each indoor unit (IC), and the S terminal on the system controller. (Non-polarized two-wire)

•Only use shielded cables.

Note

a) The heat source units in the same refrigerant circuit are automatically designated as OC and OS in the order of capacity from large to small (if two or more units have the same capacity, in the order of address from small to large).

Shielded cable connection

Daisy-chain the ground terminal (r) on the heat source units (OC, OS), the S terminal on the terminal block (TB5) on the indoor unit (IC), and the S terminal on the system controller with the shield wire of the shielded cable.

2) Transmission line for centralized control

Daisy-chain terminals M1 and M2 on the terminal block for transmission line for centralized control (TB7) on the heat source units (OC) in different refrigerant circuits and on the OC and OS in the same refrigerant circuit.

If a power supply unit is not connected to the transmission line for centralized control, replace the power jumper connector on the control board from CN41 to CN40 on only one of the heat source units.

Set the central control switch (SW5-1) on the control board of all heat source units to "ON."

Note

b) If TB7's on the heat source units in the same refrigerant circuit are not daisy-chained, connect the transmission

(5) Address setting method

Procedures	Unit or controller		Address setting range	Setting method	Notes	Factory setting	
1	Indoor unit	Main unit	IC	01 to 50	Assign the smallest address to the main unit in the group. Assign sequential numbers starting with the address of the main unit in the same group +1. (Main unit address +1, main unit address +2, main unit address +3, etc.)	To perform a group operation of indoor units that have different functions, designate the indoor unit in the group with the greatest number of functions as the main unit.	
		Sub unit					
2	LOSSNAY		LC	01 to 50	Assign an arbitrary but unique address to each of these units after assigning an address to all indoor units.	None of these addresses may overlap any of the indoor unit addresses.	00
3	MA remote controller	Main remote controller	MA	No settings required.	-	Enter the same indoor unit group settings on the system controller as the ones that were entered on the MA remote controller.	Main
		Sub remote controller	MA	Sub remote controller			
4	Heat source unit		OC OS	51 to 100	Assign sequential address to the heat source units in the same refrigerant circuit. The heat source units are automatically designated as OC and OS. (Note)	To set the address to 100, set the rotary switches to 50.	00

Note

The heat source units in the same refrigerant circuit are automatically designated as OC and OS. The heat source units are designated as OC and OS in the order of capacity from large to small (if two or more units have the same capacity, in the order of address from small to large).

line for the central control system to TB7 of the OC. (Note a).To maintain the central control even during an OC failure or a power failure, connect TB7 on OC and OS together. (If there is a problem with the heat source unit whose power jumper was moved from CN41 to CN40, central control is not possible, even if TB7's are daisy-chained.)

•Only use shielded cables.

Shielded cable connection

Daisy-chain the S terminal on the terminal block (TB7) on the heat source units (OC, OS) with the shield wire of the shielded cable. Short-circuit the earth terminal (r) and the S terminal on the terminal block (TB7) on the heat source unit whose power jumper connector is mated with CN40.

3) MA remote controller wiring

Same as [5] 1.

When 2 remote controllers are connected to the system

Same as [5] 1.

Group operation of indoor units

Same as [5] 1.

4) LOSSNAY connection

Connect terminals M1 and M2 on the terminal block (TB5) on the indoor units (IC) to the appropriate terminals on the terminal block for indoor-heat source transmission line (TB5) on LOSSNAY (LC). (Non-polarized two-wire)

•Indoor units must be interlocked with the LOSSNAY unit using the system controller. (Refer to the operation manual for the system controller for the setting method.) Interlock setting from the remote controller is required if the ON/OFF remote controller alone is connected.

5) Switch setting

Address setting is required as follows.

6. System with one heat source unit (automatic address setup for both indoor and heat source units) <PQRY>

(1) Sample control wiring

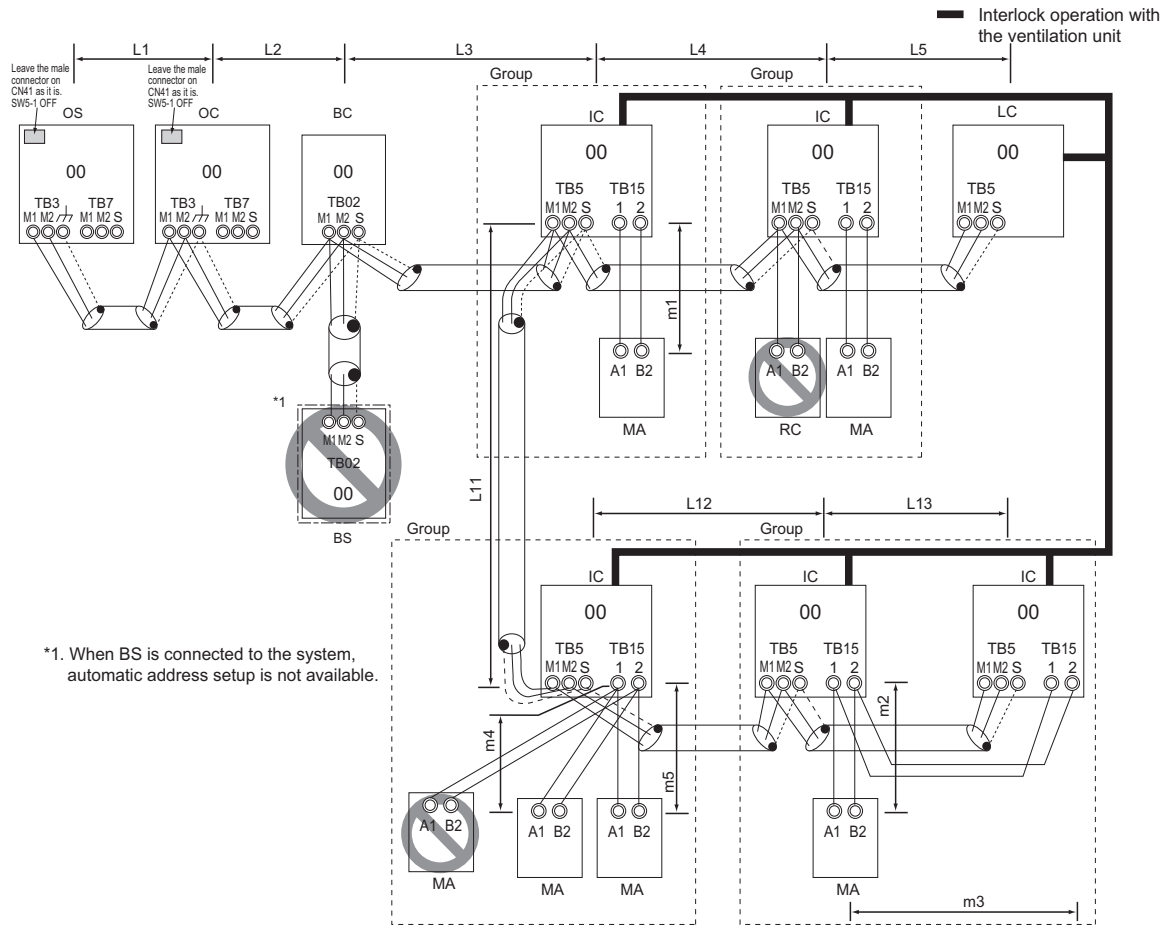

(2) Cautions

- 1) ME remote controller and MA remote controller cannot both be connected to the same group of indoor units.
- 2) No more than 2 MA remote controllers can be connected to a group of indoor units.
- 3) When the number of the connected indoor units is as shown in the table below, one or more transmission boosters (sold separately) are required.

To connect two transmission boosters, connect them in parallel. (Observe the maximum number of connectable indoor units that are listed in the specifications for each heat source unit.)

	Number of transmission booster (sold separately) required	
	1 unit	2 units
When the P72 and P96 models are not included in the connected indoor units	27 - 50 units	-
When the P72 or P96 model is included in the connected indoor units	21 - 39 units	40 - 50 units

♦The table above shows the number of transmission boosters that is required by the system with three BC controllers. For each BC controller that is subtracted from the above-mentioned system, two additional indoor units can be connected.

- 4) Automatic address setup is not available if start-stop input (CN32, CN51, CN41) is used for a group operation of indoor units. Refer to "[5] 7. Manual address setup for both indoor and heat source units"
- 5) To connect more than 2 LOSSNAY units to indoor units in the same system, refer to the next section "[5] 7. An example of a system with one heat source unit to which 2 or more LOSSNAY units are connected".

(3) Maximum allowable length

- 1) Indoor-heat source transmission line
Maximum distance (1.25mm² [AWG16] or larger)
L1 + L2 + L3 + L4 + L5 ≤ 200m [656ft]
L1 + L2 + L3 + L11 + L12 + L13 ≤ 200m [656ft]
- 2) Transmission line for centralized control
No connection is required.
- 3) MA remote controller wiring
Maximum overall line length (0.3 to 1.25mm² [AWG22 to 16])
m1 ≤ 200m [656ft]
m2 + m3 ≤ 200m [656ft]
m4 + m5 ≤ 200m [656ft]

(4) Wiring method

1) Indoor-heat source transmission line

Daisy-chain terminals M1 and M2 of the terminal block for indoor-heat source transmission line (TB3) on the heat source units (OC and OS), of the terminal block for indoor-heat source transmission line (TB02) on the main BC controller (BC), and of the terminal block for indoor-heat source transmission line (TB5) on each indoor unit (IC). (Non-polarized two-wire)

- Only use shielded cables.

Note

- a) The heat source units in the same refrigerant circuit are automatically designated as OC and OS in the order of capacity from large to small (if two or more units have the same capacity, in the order of address from small to large).

Shielded cable connection

Daisy-chain the ground terminal (G) on the heat source units (OC and OS), the S terminal of the terminal block (TB02) on the BC controller (BC), and the S terminal of the terminal block (TB5) on the indoor unit (IC) with the shield of the shielded cable.

2) Transmission line for centralized control

No connection is required.

3) MA remote controller wiring

Connect terminals 1 and 2 on the terminal block for MA remote controller line (TB15) on the indoor unit (IC) to the terminal block on the MA remote controller (MA). (Non-polarized two-wire)

When 2 remote controllers are connected to the system

When 2 remote controllers are connected to the system, connect terminals 1 and 2 of the terminal block (TB15) on the indoor unit (IC) to the terminal block on the two MA

remote controllers.

- Set one of the MA remote controllers as a sub controller. (Refer to the Instruction Manual for the MA remote controller for the setting method.)

Group operation of indoor units

To perform a group operation of indoor units (IC), daisy-chain terminals 1 and 2 on the terminal block (TB15) on all indoor units (IC) in the same group, and then connect terminals 1 and 2 on the terminal block (TB15) on the indoor unit on one end to the terminal block on the MA remotecontroller. (Non-polarized two-wire)

- When performing a group operation of indoor units that have different functions, "Automatic indoor-heat source addresssetup" is not available.

4) LOSSNAY connection

Connect terminals M1 and M2 on the terminal block(TB5) on the indoor unit (IC) to the appropriate terminals on the terminal block (TB5) on LOSSNAY (LC). (Non-polarized two-wire)

- Interlock operation setting with all the indoor units in the same system will automatically be made. (It is required that the Lossnay unit be turned on before the heat source unit.)

- When performing an interlocked operation of part of the indoor units in the system with a LOSSNAY unit, using a LOSSNAY unit alone without interlocking it with any units, performing an interlock operation of more than 16 indoor units with a LOSSNAY unit, or connecting two or more LOSSNAY units to the same refrigerant system, the automatic address setup function is not available.

5) Switch setting

No address settings required.

(5) Address setting method

Procedures	Unit or controller		Address setting range	Setting method	Notes	Factory setting
1	Indoor unit	Main unit	IC	No settings required.	-	Port number setting is required To perform a group operation of indoor units that feature different functions, the automatic IC/OC address setup function is not available.
		Sub unit	IC			
2	LOSSNAY		LC	No settings required.	-	00
3	MA remote controller	Main remote controller	MA	No settings required.	-	Main
		Sub remote controller	MA	Sub remote controller		
4	Heat source unit		OC OS	No settings required.	-	00
5	Auxiliary heat source unit	BC controller	BC	No settings required.	-	00

Note

The heat source units in the same refrigerant circuit are automatically designated as OC and OS. They are designated as OC and OS in the descending order of capacity (ascending order of address if the capacities are the same).

7. An example of a system with one heat source unit to which 2 or more LOSSNAY units are connected (manual address setup for both indoor and heat source units) <PQRY>

(1) Sample control wiring

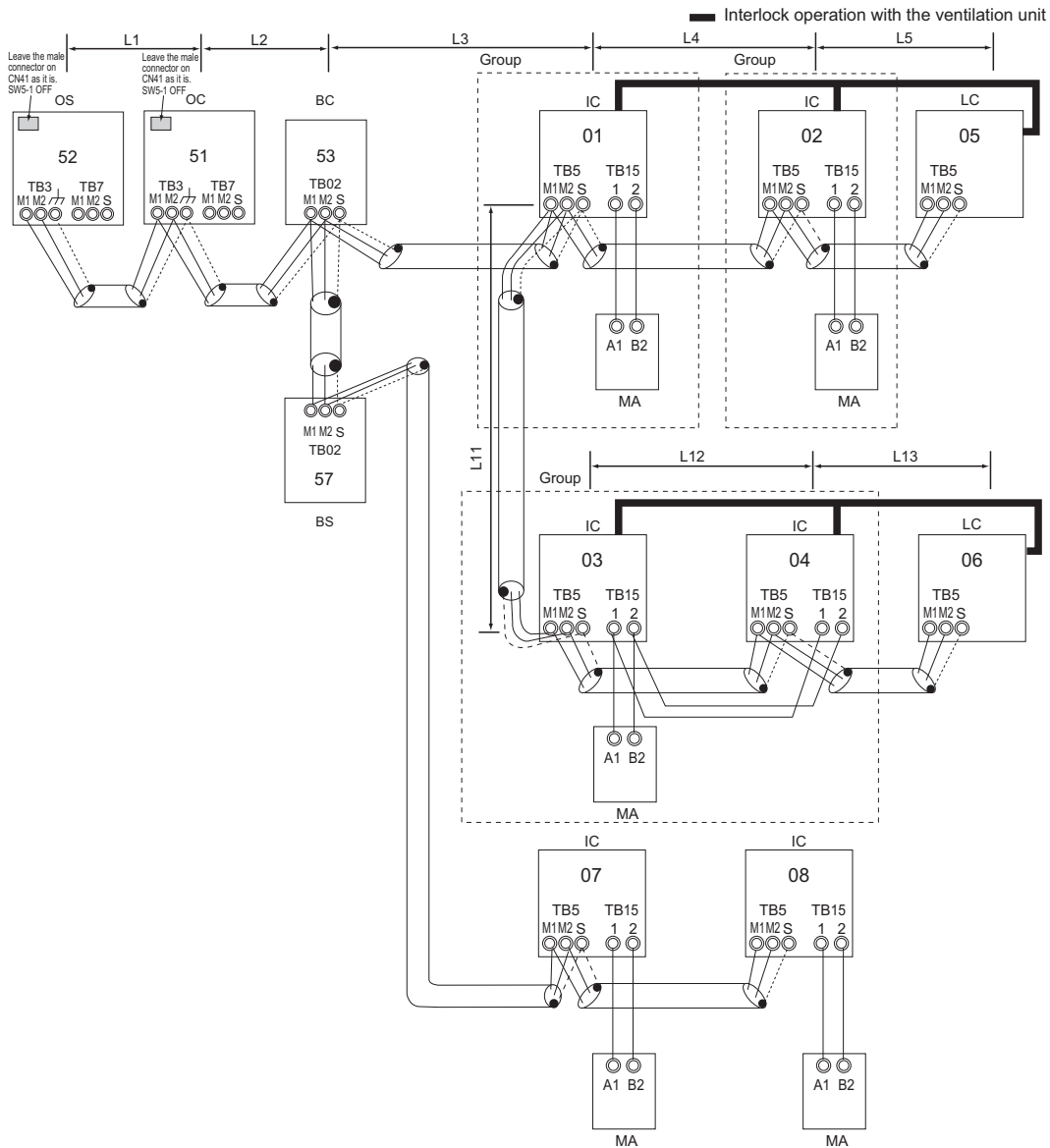

* If the BC address overlaps any of the addresses that are assigned to either the OC, OS, or BS, use a different, unused address. OC, OS, and BS addresses (lowest indoor unit address in the group plus +50) have higher priority than the BS address.

(2) Cautions

- 1) ME remote controller and MA remote controller cannot both be connected to the same group of indoor units.
- 2) No more than 2 MA remote controllers can be connected to a group of indoor units.
- 3) When the number of the connected indoor units is as shown in the table below, one or more transmission boosters (sold separately) are required. To connect two transmission boosters, connect them in parallel. (Observe the maximum number of connectable indoor units that are listed in the specifications for each heat source unit.)

- The table above shows the number of transmission boosters that is required by the system with three BC controllers. For each BC controller that is subtracted from the above-mentioned system, two additional indoor units can be connected.
- Refer to the DATABOOK for further information about how many booster units are required for a given system.

(3) Maximum allowable length

- 1) Indoor-heat source transmission line
Same as [5] 6.
- 2) Transmission line for centralized control
No connection is required.
- 3) MA remote controller wiring
Same as [5] 6.

	Number of transmission booster (sold separately) required	
	1 unit	2 units
When the P72 and P96 models are not included in the connected indoor units	27 - 50 units	-
When the P72 or P96 model is included in the connected indoor units	21 - 39 units	40 - 50 units

(4) Wiring method

- 1) Indoor-heat source transmission line
 Daisy-chain terminals M1 and M2 of the terminal block for indoor-heat source transmission line (TB3) on the heat source units (OC and OS), of the terminal block for indoor-heat source transmission line (TB02) on the main and sub BC controllers (BC and BS), and of the terminal block for indoor-heat source transmission line (TB5) on each indoor unit (IC). (Non-polarized two-wire)
 ♦Only use shielded cables.

Note

- a) The heat source units in the same refrigerant circuit are automatically designated as OC and OS in the order of capacity from large to small (if two or more units have the same capacity, in the order of address from small to large).

Shielded cable connection

Daisy-chain the ground terminal (G) on the heat source units (OC and OS), the S terminal of the terminal block (TB02) on BC and BS, and the S terminal of the terminal block (TB5) on the indoor unit (IC) with the shield of the shielded cable.

(5) Address setting method

- 2) Transmission line for centralized control
 No connection is required.
- 3) MA remote controller wiring
 Same as [5] 6.
When 2 remote controllers are connected to the system
 Same as [5] 6.
Group operation of indoor units
 Same as [5] 6.
- 4) LOSSNAY connection
 Connect terminals M1 and M2 on the terminal block (TB5) on the indoor unit (IC) to the appropriate terminals on the terminal block (TB5) on LOSSNAY (LC). (Non-polarized two-wire)
 ♦Interlock setting between the indoor units and LOSSNAY units must be entered on the remote controller. (Refer to "IV [3] Interlock Settings via the MA Remote Controller" or the installation manual for the MA remote controller for the setting method.)
- 5) Switch setting
 Address setting is required as follows.

Procedures	Unit or controller			Address setting range	Setting method	Notes	Factory setting
1	Indoor unit	Main unit	IC	01 to 50	♦Assign the smallest address to the main unit in the group. ♦In a system with a sub BC controller, make the settings for the indoor units in the following order. (i) Indoor unit to be connected to the main BC controller (ii) Indoor unit to be connected to sub BC controller 1 (iii) Indoor unit to be connected to sub BC controller 2. Make the settings for the indoor units in the way that the formula "(i) < (ii) < (iii)" is true. Assign sequential numbers starting with the address of the main unit in the same group + 1. (Main unit address + 1, main unit address + 2, main unit address + 3, etc.)	♦Port number setting is required ♦To perform a group operation of indoor units that feature different functions, designate the indoor unit in the group with the greatest number of functions as the main unit.	00
		Sub unit					
2	LOSSNAY		LC	01 to 50	Assign an arbitrary but unique address to each of these units after assigning an address to all indoor units.	None of these addresses may overlap any of the indoor unit addresses.	00
3	MA remote controller	Main remote controller	MA	No settings required.	-		Main
		Sub remote controller	MA	Sub remote controller	Settings to be made with the Sub/Main switch		
4	Heat source unit		OC OS	51 to 100	♦Assign sequential address to the heat source units in the same refrigerant circuit. ♦The heat source units are automatically designated as OC and OS.(Note)	♦To set the address to 100, set the rotary switches to 50. ♦If the addresses that is assigned to the main BC controller overlaps any of the addresses that are assigned to the heat source units or to the sub BC controller, use a different, unused address within the setting range. ♦The use of a sub BC controller requires the connection of a main BC controller.	00
5	Auxiliary heat source unit	BCcontroller (Sub)	BS	51 to 100	Assign an address that equals the sum of the smallest address of the indoor units that are connected to the sub BC controller and 50.		
		BC controller (Main)	BC		OC (or OS if it exists) + 1		

Note

The heat source units in the same refrigerant circuit are automatically designated as OC and OS. They are designated as OC and OS in the descending order of capacity (ascending order of address if the capacities are the same).

8. Group operation of units in a system with multiple heat source units <PQRY>

(1) Sample control wiring

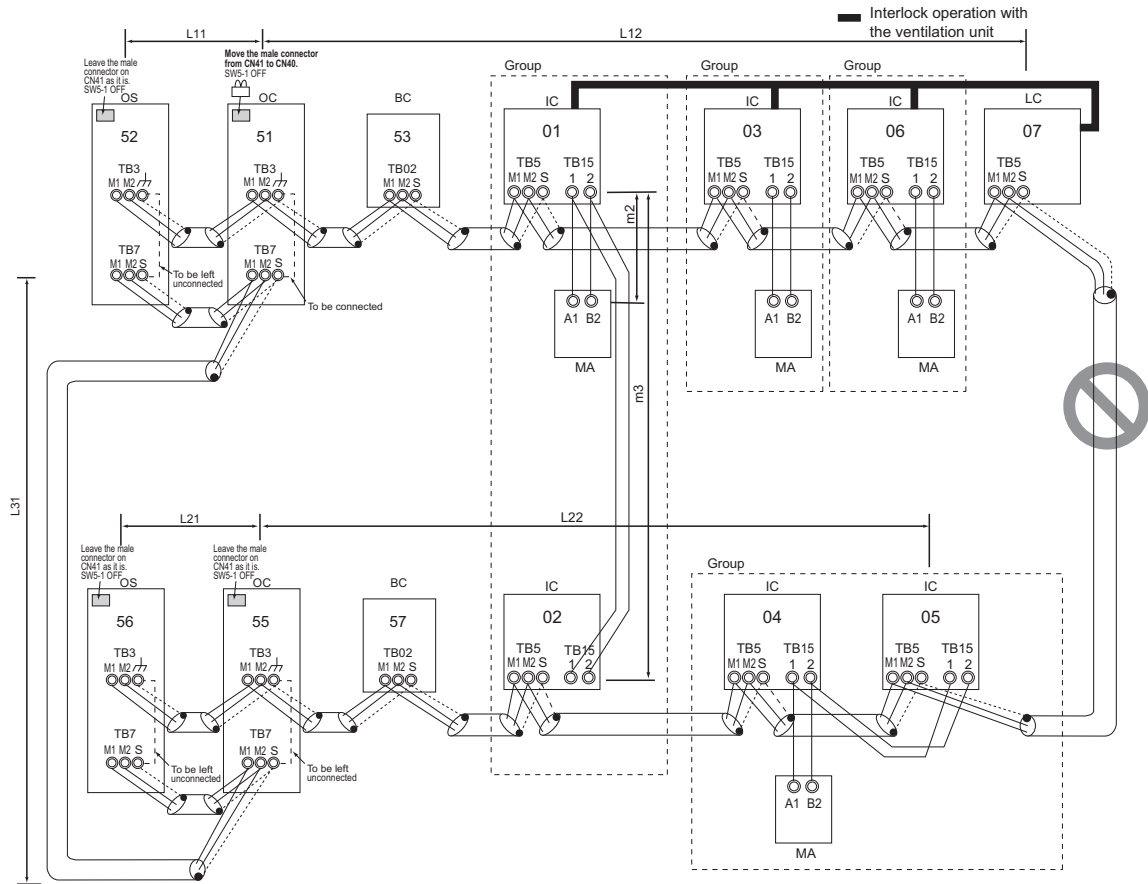

(2) Cautions

- 1) ME remote controller and MA remote controller cannot both be connected to the same group of indoor units.
- 2) No more than 2 MA remote controllers can be connected to a group of indoor units.
- 3) Do not connect the terminal blocks (TB5) on the indoor units that are connected to different heat source units with each other.
- 4) Replacement of male power jumper connector (CN41) must be performed only on one of the heat source units.
- 5) Provide grounding to S terminal on the terminal block for transmission line for centralized control (TB7) on only one of the heat source units.
- 6) When the number of the connected indoor units is as shown in the table below, one or more transmission boosters (sold separately) are required.
To connect two transmission boosters, connect them in parallel. (Observe the maximum number of connectable indoor units that are listed in the specifications for each heat source unit.)

- The left table shows the number of transmission boosters that is required by the system with three BC controllers. For each BC controller that is subtracted from the above-mentioned system, two additional indoor units can be connected.
- Refer to the DATABOOK for further information about how many booster units are required for a given system.

(3) Maximum allowable length

- 1) Indoor-heat source transmission line
Maximum distance (1.25mm² [AWG16] or larger)
L11+L12 ≤ 200m [656ft]
L21+L22 ≤ 200m [656ft]
- 2) Transmission line for centralized control
L31+L21 ≤ 200m [656ft]
- 3) MA remote controller wiring
Same as [5] 6.
- 4) Maximum line distance via heat source unit (1.25mm² [AWG16] or larger)
L12+L31+L22 ≤ 500m [1640ft]
L11+L31+L21 ≤ 500m [1640ft]

	Number of transmission booster (sold separately) required	
	1 unit	2 units
When the P72 and P96 models are not included in the connected indoor units	27 - 50 units	-
When the P72 or P96 model is included in the connected indoor units	21 - 39 units	40 - 50 units

(4) Wiring method

- 1) Indoor-heat source transmission line
Same as [5] 7.
Shielded cable connection
Same as [5] 7.
- 2) Transmission line for centralized control
Daisy-chain terminals M1 and M2 on the terminal block for transmission line for centralized control (TB7) on the heat source units (OC) in different refrigerant circuits and on the OC and OS in the same refrigerant circuit
If a power supply unit is not connected to the transmission line for centralized control, replace the power jumper connector on the control board from CN41 to CN40 on only one of the heat source units.

Note

- a) The heat source units in the same refrigerant circuit are automatically designated as OC and OS in the order of capacity from large to small (if two or more units have the same capacity, in the order of address from small to large).
- b) If TB7's on the heat source units in the same refrigerant circuit are not daisy-chained, connect the transmission line for the central control system to TB7 of the OC. (Note a).To maintain the central control even during an OC fail-

(5) Address setting method

ure or a power failure, connect TB7 on OC and OS together. (If there is a problem with the heat source unit whose power jumper was moved from CN41 to CN40, central control is not possible, even if TB7's are daisy-chained.)

•Only use shielded cables.

Shielded cable connection

Daisy-chain the S terminal on the terminal block (TB7) on the heat source units (OC, OS) with the shield wire of the shielded cable. Short-circuit the earth terminal (\overline{th}) and the S terminal on the terminal block (TB7) on the heat source unit whose power jumper connector is mated with CN40.

- 3) MA remote controller wiring

Same as [5] 6.

When 2 remote controllers are connected to the system

Same as [5] 6.

Group operation of indoor units

Same as [5] 7.

- 4) LOSSNAY connection

Same as [5] 7.

- 5) Switch setting

Address setting is required as follows.

Procedures	Unit or controller			Address setting range	Setting method	Notes	Factory setting
1	Indoor unit	Main unit	IC	01 to 50	<ul style="list-style-type: none"> •Assign the smallest address to the main unit in the group. •In a system with a sub BC controller, make the settings for the indoor units in the following order. <ol style="list-style-type: none"> (i) Indoor unit to be connected to the main BC controller (ii) Indoor unit to be connected to sub BC controller 1 (iii) Indoor unit to be connected to sub BC controller 2 Make the settings for the indoor units in the way that the formula "(i) < (ii) < (iii)" is true. 	<ul style="list-style-type: none"> •Port number setting is required •To perform a group operation of indoor units that feature different functions, designate the indoor unit in the group with the greatest number of functions as the main unit. 	00
		Sub unit					
2	LOSSNAY		LC	01 to 50	Assign an arbitrary but unique address to each of these units after assigning an address to all indoor units.	None of these addresses may overlap any of the indoor unit addresses.	00
3	MA remote controller	Main remote controller	MA	No settings required.	-		Main
		Sub remote controller	MA	Sub remote controller	Settings to be made with the Sub/Main switch		
4	Heat source unit		OC OS	51 to 100	<ul style="list-style-type: none"> •Assign sequential address to the heat source units in the same refrigerant circuit. •The heat source units are automatically designated as OC and OS.(Note) 	<ul style="list-style-type: none"> •To set the address to 100, set the rotary switches to 50. •If the addresses that is assigned to the main BC controller overlaps any of the addresses that are assigned to the heat source units or to the sub BC controller, use a different, unused address within the setting range. 	00
5	Auxiliary heat source unit	BCcontroller (Sub)	BS	51 to 100	Assign an address that equals the sum of the smallest address of the indoor units that are connected to the sub BC controller and 50.	<ul style="list-style-type: none"> •The use of a sub BC controller requires the connection of a main BC controller. 	
		BC controller (Main)	BC		OC (or OS if it exists) +1		

Note

The heat source units in the same refrigerant circuit are automatically designated as OC and OS. They are designated as OC and OS in the descending order of capacity (ascending order of address if the capacities are the same).

9. A system in which a system controller is connected to the transmission line for centralized control and which is powered from a heat source unit <PQR>

(1) Sample control wiring

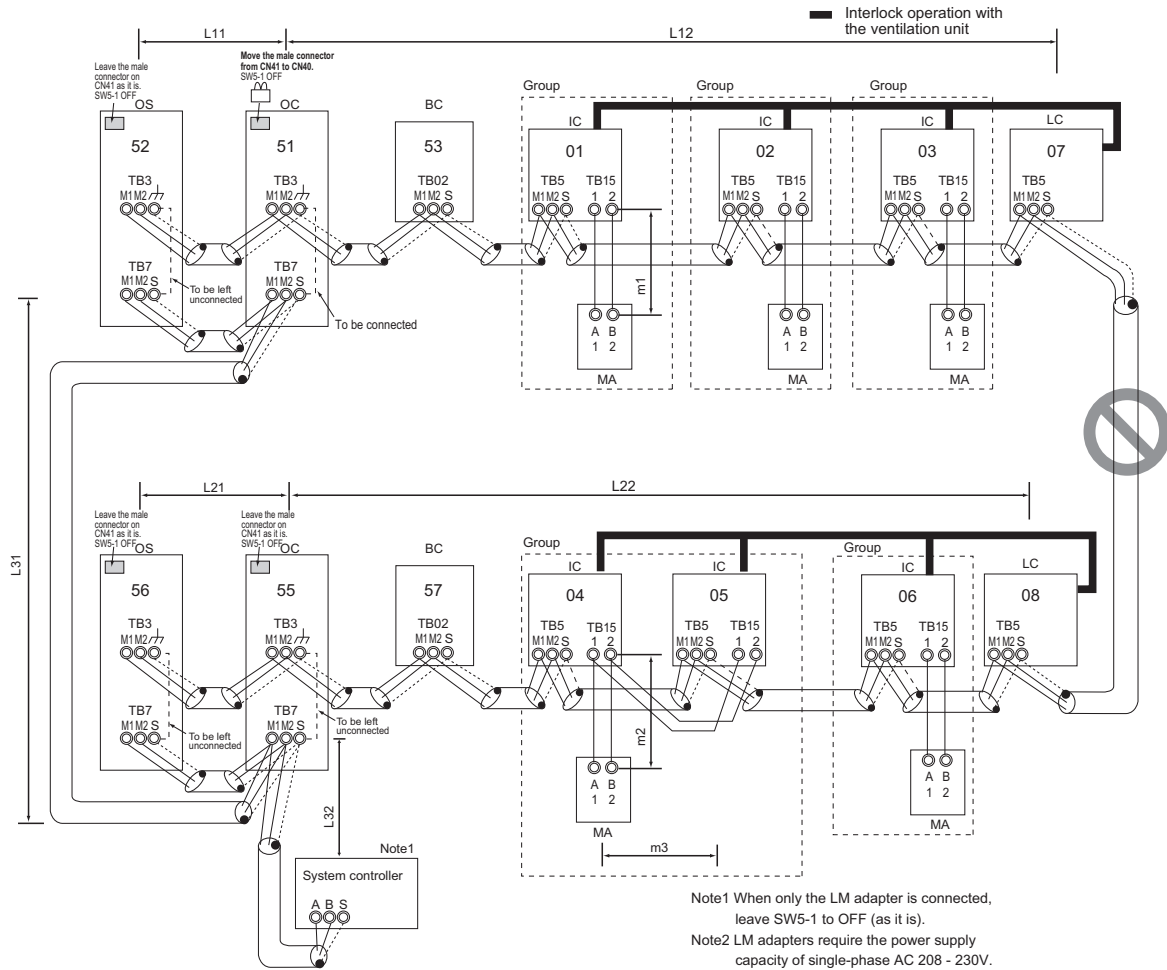

(2) Cautions

- 1) ME remote controller and MA remote controller cannot both be connected to the same group of indoor units.
- 2) No more than 2 MA remote controllers can be connected to a group of indoor units.
- 3) Do not connect the terminal blocks (TB5) on the indoor units that are connected to different heat source units with each other.
- 4) Replacement of male power jumper connector (CN41) must be performed only on one of the heat source units.
- 5) Short-circuit the shield terminal (S terminal) and the earth terminal (⌚) on the terminal block for transmission line for centralized control (TB7) on the heat source unit whose power jumper connector is mated with CN40.
- 6) When the number of the connected indoor units is as shown in the table below, one or more transmission boosters (sold separately) are required.
 To connect two transmission boosters, connect them in parallel. (Observe the maximum number of connectable indoor units that are listed in the specifications for each heat source unit.)

	Number of transmission booster (sold separately) required	
	1 unit	2 units
When the P72 and P96 models are not included in the connected indoor units	27 - 50 units	-
When the P72 or P96 model is included in the connected indoor units	21 - 39 units	40 - 50 units

- The left table shows the number of transmission boosters that is required by the system with three BC controllers. For each BC controller that is subtracted from the above-mentioned system, two additional indoor units can be connected.
 - Refer to the DATABOOK for further information about how many booster units are required for a given system.
- 7) When a power supply unit is connected to the transmission line for centralized control, leave the power jumper connector on CN41 as it is (factory setting).

(3) Maximum allowable length

- 1) Indoor-heat source transmission line
 Same as [5] 8.
- 2) Transmission line for centralized control
 Maximum line distance via heat source unit (1.25 mm² [AWG16] min.)
 $L31+L32(L21) \leq 200m$ [656ft]
- 3) MA remote controller wiring
 Same as [5] 6.
- 4) Maximum line distance via heat source unit (1.25mm² [AWG16] or larger)
 $L32+L31+L12(L11) \leq 500m$ [1640ft]
 $L32+L22(L21) \leq 500m$ [1640ft]
 $L12(L11)+L31+L22(L21) \leq 500m$ [1640ft]

(4) Wiring method

- 1) Indoor-heat source transmission line
Same as [5] 7.
Only use shielded cables.
Shielded cable connection
Same as [5] 7.
- 2) Transmission line for centralized control
Daisy-chain terminals A and B on the system controller, terminals M1 and M2 on the terminal block for transmission line for centralized control (TB7) on the heat source units (OC) in different refrigerant circuits and on the heat source units (OC and OS) in the same refrigerant circuit.
If a power supply unit is not connected to the transmission line for centralized control, replace the power jumper connector on the control board from CN41 to CN40 on only one of the heat source units.
If a system controller is connected, set the central control switch (SW5-1) on the control board of all heat source units to "ON."

Note

- a) The heat source units in the same refrigerant circuit are automatically designated as OC and OS in the order of capacity from large to small (if two or more units have the same capacity, in the order of address from small to large).
- b) If TB7's on the heat source units in the same refrigerant circuit are not daisy-chained, connect the transmission line for the central control system to TB7 of the OC. (Note a). To maintain the central control even during an OC failure or a power failure, connect TB7 on OC and OS together. (If there

is a problem with the heat source unit whose power jumper was moved from CN41 to CN40, central control is not possible, even if TB7's are daisy-chained.)

- Only use shielded cables.

Shielded cable connection

Daisy-chain the S terminal of the terminal block (TB7) on the system controller, OC, and OS with the shield of the shielded cable. Short-circuit the earth terminal () and the S terminal on the terminal block (TB7) on the heat source unit whose power jumper connector is mated with CN40.

- 3) MA remote controller wiring
Same as [5] 6.
When 2 remote controllers are connected to the system
Same as [5] 6.
Group operation of indoor units
Same as [5] 6.
- 4) LOSSNAY connection
Connect terminals M1 and M2 on the terminal block (TB5) on the indoor unit (IC) to the appropriate terminals on the terminal block for indoor-heat source transmission line (TB5) on LOSSNAY (LC). (Non-polarized two-wire)
• Indoor units must be interlocked with the LOSSNAY unit using the system controller. (Refer to the operation manual for the system controller for the setting method.) Interlock setting from the remote controller is required if the ON/OFF remote controller alone or the LM adapter alone is connected.
- 5) Switch setting
Address setting is required as follows.

(5) Address setting method

Procedures	Unit or controller			Address setting range	Setting method	Notes	Factory setting
1	Indoor unit	Main unit	IC	01 to 50	<ul style="list-style-type: none"> • Assign the smallest address to the main unit in the group. • In a system with a sub BC controller, make the settings for the indoor units in the following order. <ul style="list-style-type: none"> (i) Indoor unit to be connected to the main BC controller (ii) Indoor unit to be connected to sub BC controller 1 (iii) Indoor unit to be connected to sub BC controller 2 Make the settings for the indoor units in the way that the formula "(i) < (ii) < (iii)" is true. 	<ul style="list-style-type: none"> • Port number setting is required • To perform a group operation of indoor units that feature different functions, designate the indoor unit in the group with the greatest number of functions as the main unit. 	00
		Sub unit					
2	LOSSNAY		LC	01 to 50	Assign an arbitrary but unique address to each of these units after assigning an address to all indoor units.	None of these addresses may overlap any of the indoor unit addresses.	00
3	MA remote controller	Main remote controller	MA	No settings required.	-	Make the same indoor unit group settings with the system controller as the ones that were made with the MA remote controller.	Main
		Sub remote controller	MA	Sub remote controller	Settings to be made with the Sub/Main switch		
4	Heat source unit (Note)		OC OS	51 to 100	<ul style="list-style-type: none"> • Assign sequential address to the heat source units in the same refrigerant circuit. • The heat source units are automatically designated as OC and OS. (Note) 	<ul style="list-style-type: none"> • To set the address to 100, set the rotary switches to 50. • If the addresses that is assigned to the main BC controller overlaps any of the addresses that are assigned to the heat source units or to the sub BC controller, use a different, unused address within the setting range. 	00
5	Auxiliary heat source unit	BC controller (Sub)	BS	51 to 100	Assign an address that equals the sum of the smallest address of the indoor units that are connected to the sub BC controller and 50.	<ul style="list-style-type: none"> • The use of a sub BC controller requires the connection of a main BC controller. 	
		BC controller (Main)	BC				

Note

The heat source units in the same refrigerant circuit are automatically designated as OC and OS. They are designated as OC and OS in the descending order of capacity (ascending order of address if the capacities are the same).

10. An example of a system in which a system controller is connected to the indoor-heat source transmission line (except LM adapter) <PQRY>

(1) Sample control wiring

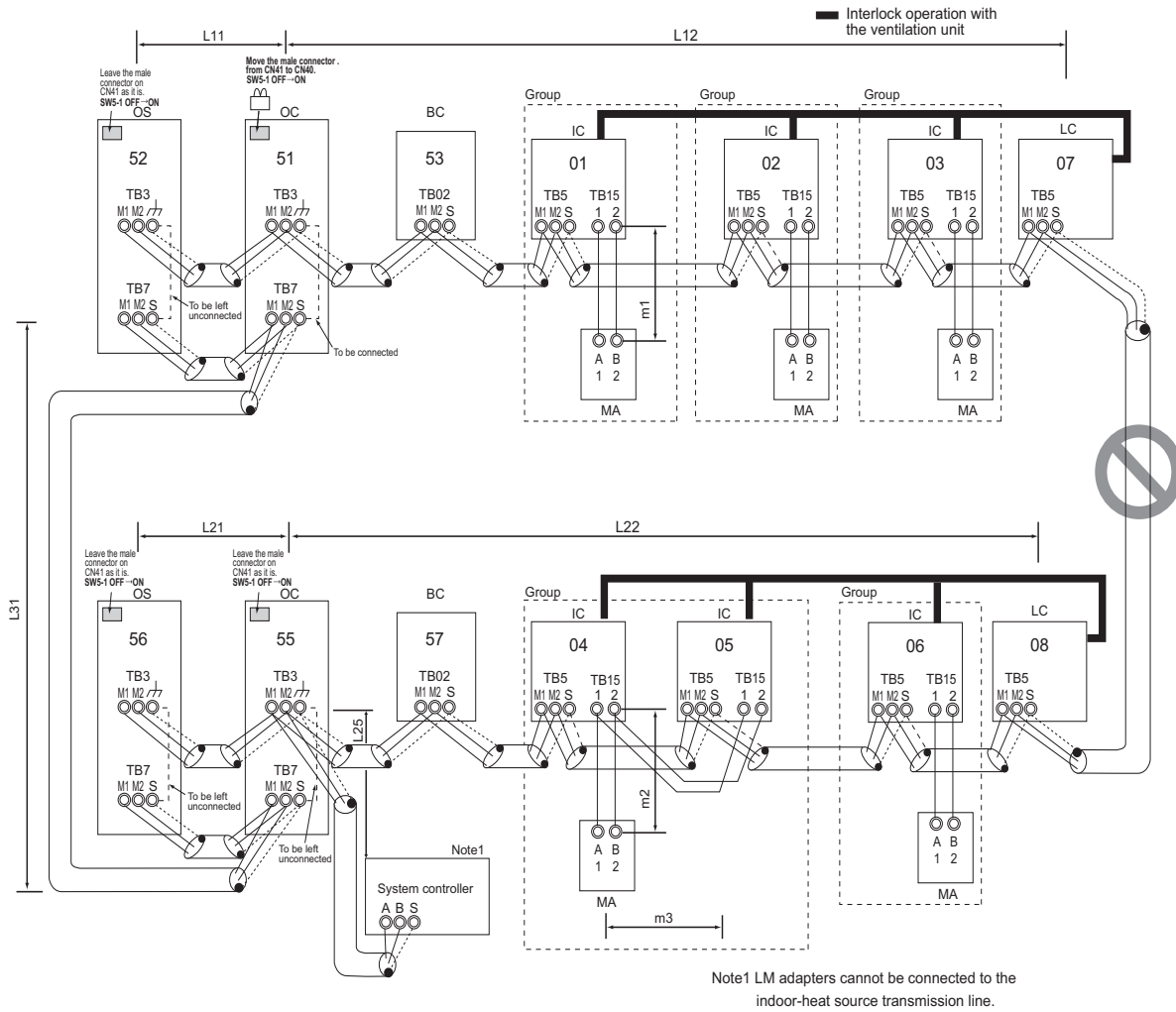

(2) Cautions

- 1) ME remote controller and MA remote controller cannot both be connected to the same group of indoor units.
- 2) No more than 2 MA remote controllers can be connected to a group of indoor units.
- 3) Do not connect the terminal blocks (TB5) on the indoor units that are connected to different heat source units with each other.
- 4) Replacement of male power jumper connector (CN41) must be performed only on one of the heat source units.
- 5) Provide grounding to S terminal on the terminal block for transmission line for centralized control (TB7) on only one of the heat source units.
- 6) A maximum of 3 system controllers can be connected to the indoor-heat source transmission line, with the exception that only one G(B)-50A may be connected.
- 7) When the total number of indoor units exceeds 20 (12 if one or more indoor units of the 72 model or above is connected), it may not be possible to connect a system controller to the indoor-heat source transmission line.
- 8) When the number of the connected indoor units is as shown in the table below, one or more transmission boosters (sold separately) are required.
To connect two transmission boosters, connect them in parallel.
(Observe the maximum number of connectable indoor units that are listed in the specifications for each heat source unit.)

	Number of transmission booster (sold separately) required	
	1 unit	2 units
When the P72 and P96 models are not included in the connected indoor units	27 - 50 units	-
When the P72 or P96 model is included in the connected indoor units	21 - 39 units	40 - 50 units

•The table above shows the number of transmission boosters that is required by the system with three BC controllers. For each BC controller that is subtracted from the above-mentioned system, two additional indoor units can be connected.
•Refer to the DATABOOK for further information about how many booster units are required for a given system.

(3) Maximum allowable length

- 1) Indoor-heat source transmission line
Maximum distance (1.25mm² [AWG16] or larger)
L11+L12 ≤ 200m [656ft]
L21+L22 ≤ 200m [656ft]
L25 ≤ 200m [656ft]
- 2) Transmission line for centralized control
L31+L21 ≤ 200m [656ft]
- 3) MA remote controller wiring
Same as [5] 6.
- 4) Maximum line distance via heat source unit (1.25mm² [AWG16] or larger)
L25+L31+L12(L11) ≤ 500m [1640ft]
L12(L11)+L31+L22(L21) ≤ 500m [1640ft]

(4) Wiring method

1) Indoor-heat source transmission line

Daisy-chain terminals M1 and M2 of the terminal block for indoor-heat source transmission line (TB3) on the heat source units (OC and OS), of the terminal block for indoor-heat source transmission line (TB02) on the main and sub BC controllers (BC and BS), of the terminal block for indoor-heat source transmission line (TB5) on each indoor unit (IC), and the S terminal of the system controller.(Non-polarized two-wire)

- Only use shielded cables.

Note

- a) The heat source units in the same refrigerant circuit are automatically designated as OC and OS in the order of capacity from large to small (if two or more units have the same capacity, in the order of address from small to large).

Shielded cable connection

Daisy-chain the ground terminal (\overline{TT}) on the heat source units (OC and OS), the S terminal of the terminal block (TB02) on the BC and BS, and the S terminal of the terminal block (TB5) on the indoor unit (IC) with the shield of the shielded cable.

2) Transmission line for centralized control

Daisy-chain terminals M1 and M2 on the terminal block for transmission line for centralized control (TB7) on the heat source units (OC) in different refrigerant circuits and on the OC and OS in the same refrigerant circuit.

If a power supply unit is not connected to the transmission line for centralized control, replace the power jumper connector on the control board from CN41 to CN40 on only one of the heat source units. Set the central control switch (SW5-1) on the control board of all heat source units to "ON."

Note

- b) If TB7's on the heat source units in the same refrigerant circuit are

(5) Address setting method

not daisy-chained, connect the transmission line for the central control system to TB7 of the OC. (Note a). To maintain the central control even during an OC failure or a power failure, connect TB7 on OC and OS together. (If there is a problem with the heat source unit whose power jumper was moved from CN41 to CN40, central control is not possible, even if TB7's are daisy-chained.)

- Only use shielded cables.

Shielded cable connection

Daisy-chain the S terminal on the terminal block (TB7) on the heat source units (OC, OS) with the shield wire of the shielded cable. Short-circuit the earth terminal (\overline{TT}) and the S terminal on the terminal block (TB7) on the heat source unit whose power jumper connector is mated with CN40.

3) MA remote controller wiring

Same as [5] 6.

When 2 remote controllers are connected to the system

Same as [5] 6.

Group operation of indoor units

Same as [5] 6.

4) LOSSNAY connection

Connect terminals M1 and M2 on the terminal block (TB5) on the indoor units (IC) to the appropriate terminals on the terminal block for indoor-heat source transmission line (TB5) on LOSSNAY (LC). (Non-polarized two-wire)

- Indoor units must be interlocked with the LOSSNAY unit using the system controller. (Refer to the operation manual for the system controller for the setting method.) Interlock setting from the remote controller is required if the ON/OFF remote controller alone is connected.

5) Switch setting

Address setting is required as follows.

Procedures	Unit or controller			Address setting range	Setting method	Notes	Factory setting
1	Indoor unit	Main unit	IC	01 to 50	<ul style="list-style-type: none"> •Assign the smallest address to the main unit in the group. •In a system with a sub BC controller, make the settings for the indoor units in the following order. <ul style="list-style-type: none"> (i) Indoor unit to be connected to the main BC controller (ii) Indoor unit to be connected to sub BC controller 1 (iii) Indoor unit to be connected to sub BC controller 2 Make the settings for the indoor units in the way that the formula "(i) < (ii) < (iii)" is true. 	<ul style="list-style-type: none"> •Port number setting is required •To perform a group operation of indoor units that feature different functions, designate the indoor unit in the group with the greatest number of functions as the main unit. 	00
		Sub unit					
2	LOSSNAY		LC	01 to 50	Assign an arbitrary but unique address to each of these units after assigning an address to all indoor units.	None of these addresses may overlap any of the indoor unit addresses.	00
3	MA remote controller	Main remote controller	MA	No settings required.	-	Make the same indoor unit group settings with the system controller as the ones that were made with the MA remote controller.	Main
		Sub remote controller	MA	Sub remote controller	Settings to be made with the Sub/Main switch		
4	Heat source unit		OC OS	51 to 100	<ul style="list-style-type: none"> •Assign sequential address to the heat source units in the same refrigerant circuit. •The heat source units are automatically designated as OC and OS.(Note) 	<ul style="list-style-type: none"> •To set the address to 100, set the rotary switches to 50. •If the addresses that is assigned to the main BC controller overlaps any of the addresses that are assigned to the heat source units or to the sub BC controller, use a different, unused address within the setting range. •The use of a sub BC controller requires the connection of a main BC controller. 	00
5	Auxiliary heat source unit	BCcontroller (Sub)	BS	51 to 100	Assign an address that equals the sum of the smallest address of the indoor units that are connected to the sub BC controller and 50.		
		BC controller (Main)	BC				

Note

The heat source units in the same refrigerant circuit are automatically designated as OC and OS. They are designated as OC and OS in the descending order of capacity (ascending order of address if the capacities are the same).

11. A system with multiple BC controller connections (with a system controller connected to the centralized control line) <PQRY>

(1) Sample control wiring

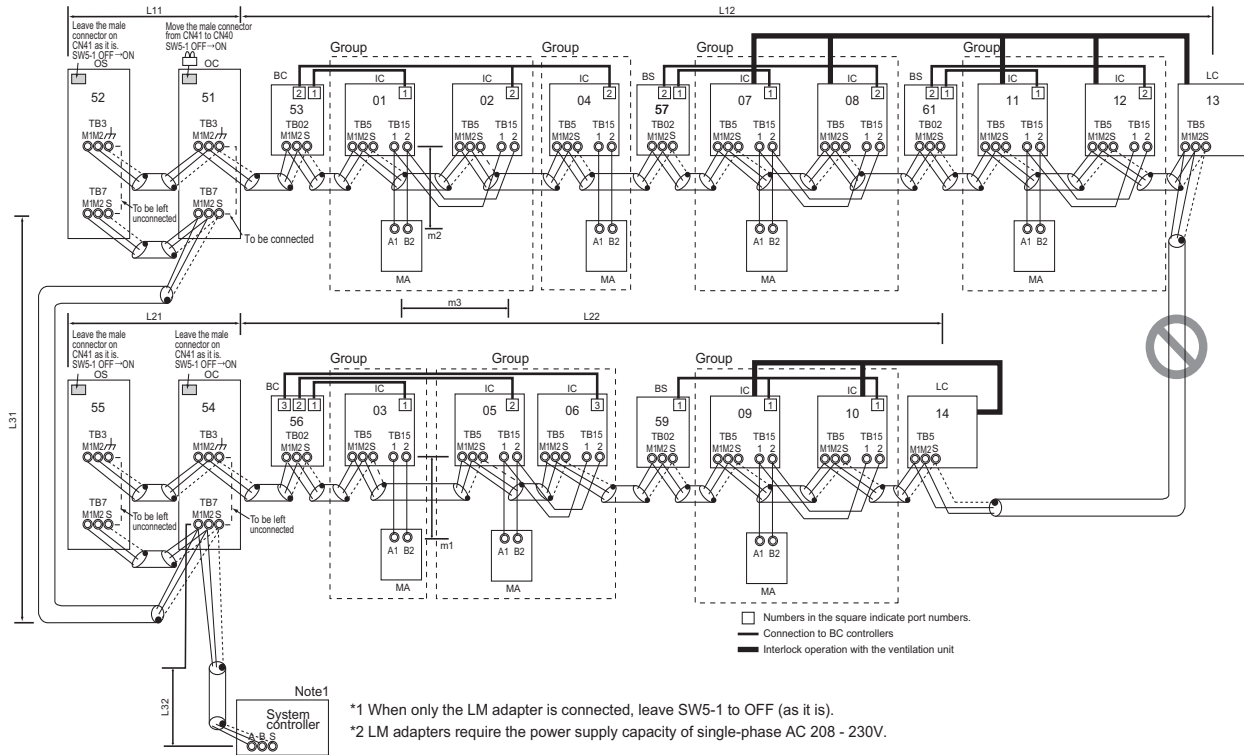

(2) Cautions

- 1) ME remote controller and MA remote controller cannot both be connected to the same group of indoor units.
- 2) No more than 2 MA remote controllers can be connected to a group of indoor units.
- 3) Do not connect the terminal blocks (TB5) on the indoor units that are connected to different heat source units with each other.
- 4) Replacement of male power jumper connector (CN41) must be performed only on one of the heat source units.
- 5) Short-circuit the S (shield) terminal of the terminal block for the central control unit (TB7) and the ground terminal (⏏) on the heat source unit whose power jumper was moved from CN41 to CN40.
- 6) When the number of the connected indoor units is as shown in the table below, one or more transmission boosters (sold separately) are required.
To connect two transmission boosters, connect them in parallel.
(Observe the maximum number of connectable indoor units that are listed in the specifications for each heat source unit.)

	Number of transmission booster (sold separately) required	
	1 unit	2 units
When the P72 and P96 models are not included in the connected indoor units	27 - 50 units	-
When the P72 or P96 model is included in the connected indoor units	21 - 39 units	40 - 50 units

- The table above shows the number of transmission boosters that is required by the system with three BC controllers. For each BC controller that is subtracted from the above-mentioned system, two additional indoor units can be connected.
 - Refer to the DATABOOK for further information about how many booster units are required for a given system.
- 7) When a power supply unit is connected to the transmission line for centralized control, leave the power jumper connector on CN41 as it is (factory setting).

(3) Maximum allowable length

- 1) Indoor-heat source transmission line
Maximum distance (1.25mm² [AWG16] or larger)
L11+L12 ≤ 200m [656ft]
L21+L22 ≤ 200m [656ft]
- 2) Transmission line for centralized control
L31+L32(L21) ≤ 200m [656ft]
- 3) MA remote controller wiring
Maximum overall line length (0.3 to 1.25mm² [AWG22 to 16])
m1 ≤ 200m [656ft]
m2+m3 ≤ 200m [656ft]
- 4) Maximum line distance via heat source unit (1.25mm² [AWG16] or larger)
L32+L31+L12(L11) ≤ 500m [1640ft]
L32+L22(L21) ≤ 500m [1640ft]
L12(L11)+L31+L22(L21) ≤ 500m [1640ft]

(4) Wiring method

1) Indoor-heat source transmission line

Daisy-chain terminals M1 and M2 of the terminal block for indoor-heat source transmission line (TB3) on the heat source units (OC and OS), of the terminal block for indoor-heat source transmission line (TB02) on the main and sub BC controllers (BC and BS), and of the terminal block for indoor-heat source transmission line (TB5) on each indoor unit (IC). (Non-polarized two-wire)

Shielded cable connection

Note

a) The heat source units in the same refrigerant circuit are automatically designated as OC and OS in the order of capacity from large to small (if two or more units have the same capacity, in the order of address from small to large).

Daisy-chain the ground terminal (G) on the heat source units (OC and OS), the S terminal of the terminal block (TB02) on the BC and BS, and the S terminal of the terminal block (TB5) on the indoor unit (IC) with the shield of the shielded cable.

•Only use shielded cables.

2) Transmission line for centralized control

Daisy-chain terminals A and B on the terminal block for transmission line for centralized control (TB7) on the heat source units (OC) in different refrigerant circuits and on the OC and OS (Note) in the same refrigerant circuit.

If a power supply unit is not connected to the transmission line for centralized control, replace the power jumper connector on the control board from CN41 to CN40 on only one of the heat source units. Set the central control switch (SW5-1) on the control board of all heat source units to "ON."

Note

b) If TB7's on the heat source units in the same refrigerant circuit are

not daisy-chained, connect the transmission line for the central control system to TB7 of the OC. (Note a). To maintain the central control even during an OC failure or a power failure, connect TB7 on OC and OS together. (If there is a problem with the heat source unit whose power jumper was moved from CN41 to CN40, central control is not possible, even if TB7's are daisy-chained.)

•Only use shielded cables.

Shielded cable connection

Daisy-chain the S terminal of the terminal block (TB7) on the system controller, OC, and OS with the shield of the shielded cable. Short-circuit the earth terminal (E) and the S terminal on the terminal block (TB7) on the heat source unit whose power jumper connector is mated with CN40.

3) MA remote controller wiring

Same as [5] 6.

When 2 remote controllers are connected to the system

Same as [5] 6.

Group operation of indoor units

Same as [5] 6.

4) LOSSNAY connection

Connect terminals M1 and M2 on the terminal block (TB5) on the indoor unit (IC) to the appropriate terminals on the terminal block for indoor-heat source transmission line (TB5) on LOSSNAY (LC). (Non-polarized two-wire)

•Indoor units must be interlocked with the LOSSNAY unit using the system controller. (Refer to the operation manual for the system controller for the setting method.) Interlock setting from the remote controller is required if the ON/OFF remote controller alone or the LM adapter alone is connected.

5) Switch setting

Address setting is required as follows.

(5) Address setting method

Procedures	Unit or controller			Address setting range	Setting method	Notes	Factory setting
1	Indoor unit	Main unit	IC	01 to 50	<ul style="list-style-type: none"> Assign the smallest address to the main unit in the group. In a system with a sub BC controller, make the settings for the indoor units in the following order. <ul style="list-style-type: none"> (i) Indoor unit to be connected to the main BC controller (ii) Indoor unit to be connected to sub BC controller 1 (iii) Indoor unit to be connected to sub BC controller 2 Make the settings for the indoor units in the way that the formula "(i) < (ii) < (iii)" is true. 	<ul style="list-style-type: none"> Port number setting is required To perform a group operation of indoor units that feature different functions, designate the indoor unit in the group with the greatest number of functions as the main unit. 	00
		Sub unit					
2	LOSSNAY		LC	01 to 50	Assign an arbitrary but unique address to each of these units after assigning an address to all indoor units.	None of these addresses may overlap any of the indoor unit addresses.	00
3	MA remote controller	Main remote controller	MA	No settings required.	-	Make the same indoor unit group settings with the system controller as the ones that were made with the MA remote controller.	Main
		Sub remote controller	MA	Sub remote controller	Settings to be made with the Sub/Main switch		
4	Heat source unit		OC OS	51 to 100	<ul style="list-style-type: none"> The sum of the smallest address of the indoor units in the same system and 50. Assign sequential address to the heat source units in the same refrigerant circuit. The heat source units are automatically designated as OC and OS. (Note) 	<ul style="list-style-type: none"> To set the address to 100, set the rotary switches to 50. 	00
5	Auxiliary heat source unit	BC controller (Sub)	BS	51 to 100	Assign an address that equals the sum of the smallest address of the indoor units that are connected to the sub BC controller and 50.	<ul style="list-style-type: none"> To set the address to 100, set the rotary switches to 50. If the addresses that is assigned to the main BC controller overlaps any of the addresses that are assigned to the heat source units or to the sub BC controller, use a different, unused address within the setting range. The use of a sub BC controller requires the connection of a main BC controller. 	00
		BC controller (Main)	BC	51 to 100	OC (or OS if it exists) +1		

Note

The heat source units in the same refrigerant circuit are automatically designated as OC and OS. They are designated as OC and OS in the descending order of capacity (ascending order of address if the capacities are the same).

[6] An Example of a System to which an ME Remote Controller is connected

1. A system in which a system controller is connected to the centralized control transmission line <PQHY>

(1) Sample control wiring

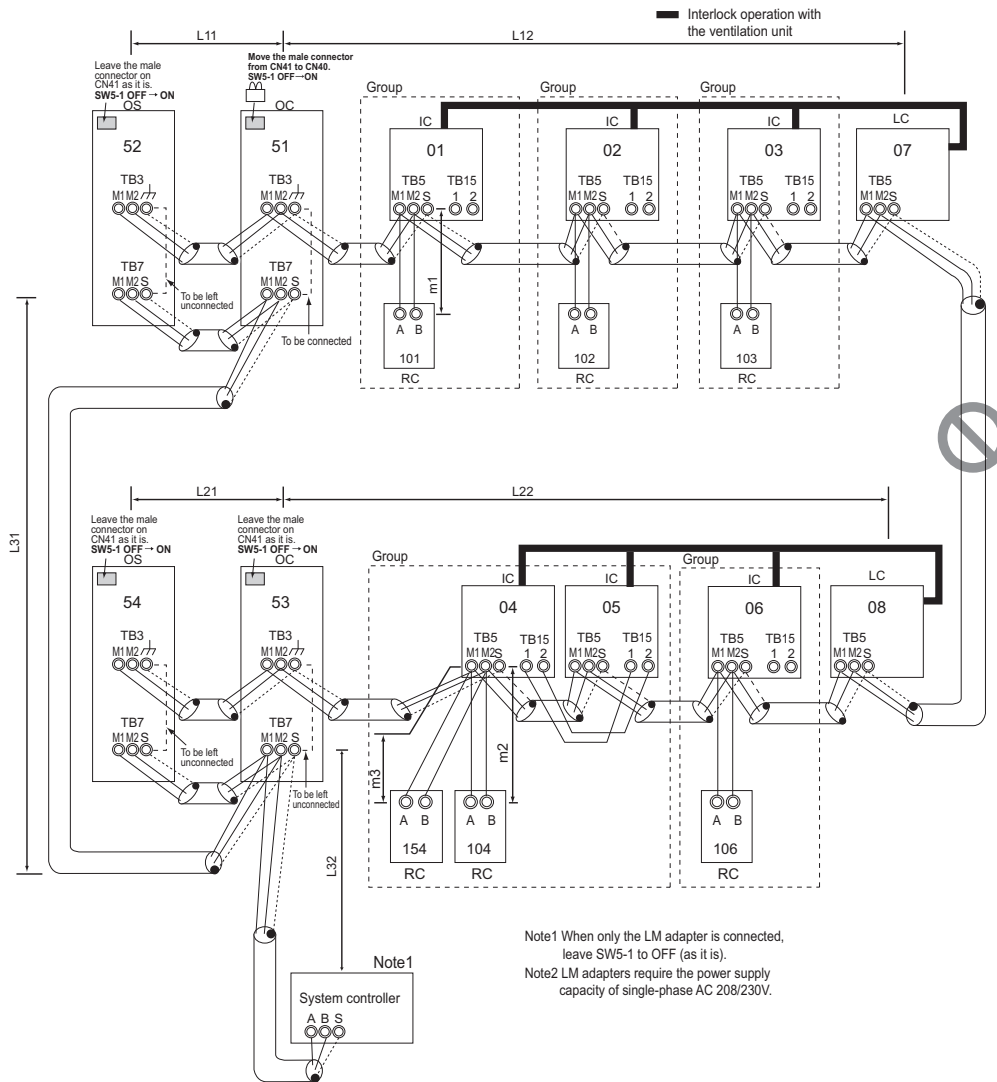

(2) Cautions

- 1) ME remote controller and MA remote controller cannot both be connected to the same group of indoor units.
- 2) No more than 3 ME remote controllers can be connected to a group of indoor units.
- 3) Do not connect the terminal blocks (TB5) on the indoor units that are connected to different heat source units with each other.
- 4) Replace the power jumper connector of the control board from CN41 to CN40 on only one of the heat source units.
- 5) Provide an electrical path to ground for the S terminal on the terminal block for centralized control on only one of the heat source units.
- 6) A transmission booster must be connected to a system in which the total number of connected indoor units exceeds 20.
- 7) A transmission booster is required in a system to which more than 16 indoor including one or more indoor units of the 72 model or above are connected.
 - ♦Refer to the DATABOOK for further information about how many booster units are required for a given system.
- 8) When a power supply unit is connected to the transmission line for centralized control, leave the power jumper connector on CN41 as it is (factory setting).

(3) Maximum allowable length

- 1) Indoor-heat source transmission line
Same as [5] 3.
- 2) Transmission line for centralized control
Same as [5] 4.
- 3) ME remote controller wiring
Maximum overall line length
(0.3 to 1.25mm² [AWG22 to 16])
m1 ≤ 10m [32ft]
m2+m3 ≤ 10m [32ft]
If the standard-supplied cable must be extended, use a cable with a diameter of 1.25mm² [AWG16]. The section of the cable that exceeds 10m [32ft] must be included in the maximum indoor-heat source transmission line distance described in 1).
When connected to the terminal block on the Simple remote controller, use cables that meet the following cable size specifications: 0.75 - 1.25 mm² [AWG18-14].
- 4) Maximum line distance via heat source unit
(1.25mm² or larger)
Same as [5] 4.

(4) Wiring method

- 1) Indoor-heat source transmission line
Same as [5] 1.
Shielded cable connection
Same as [5] 1.
- 2) Transmission line for centralized control
Same as [5] 4.
Shielded cable connection
Same as [5] 4.
- 3) ME remote controller wiring
ME remote controller is connectable anywhere on the indoor-heat source transmission line.

When 2 remote controllers are connected to the system

- Refer to the section on Switch Setting.
Performing a group operation (including the group operation of units in different refrigerant circuits).
Refer to the section on Switch Setting.
- 4) LOSSNAY connection
Same as [5] 4.
 - 5) Switch setting
Address setting is required as follows.

(5) Address setting method

Procedures	Unit or controller			Address setting range	Setting method	Notes	Factory setting
1	Indoor unit	Main unit	IC	01 to 50	Assign the smallest address to the main unit in the group.	To perform a group operation of indoor units that have different functions, designate the indoor unit in the group with the greatest number of functions as the main unit.	00
		Sub unit			Assign sequential numbers starting with the address of the main unit in the same group +1. (Main unit address +1, main unit address +2, main unit address +3, etc.)		
2	LOSSNAY		LC	01 to 50	Assign an arbitrary but unique address to each of these units after assigning an address to all indoor units.	None of these addresses may overlap any of the indoor unit addresses.	00
3	ME remote controller	Main remote controller	RC	101 to 150	Add 100 to the main unit address in the group	<ul style="list-style-type: none"> •It is not necessary to set the 100s digit. •To set the address to 200, set the rotary switches to 00. 	101
		Sub remote controller	RC	151 to 200	Add 150 to the main unit address in the group		
4	Heat source unit		OC OS	51 to 100	Assign sequential address to the heat source units in the same refrigerant circuit. The heat source units are automatically designated as OC and OS. (Note)	To set the address to 100, set the rotary switches to 50.	00

Note

The heat source units in the same refrigerant circuit are automatically designated as OC and OS.

2. A system in which a system controller is connected to the centralized control transmission line <PQRY>

(1) Sample control wiring

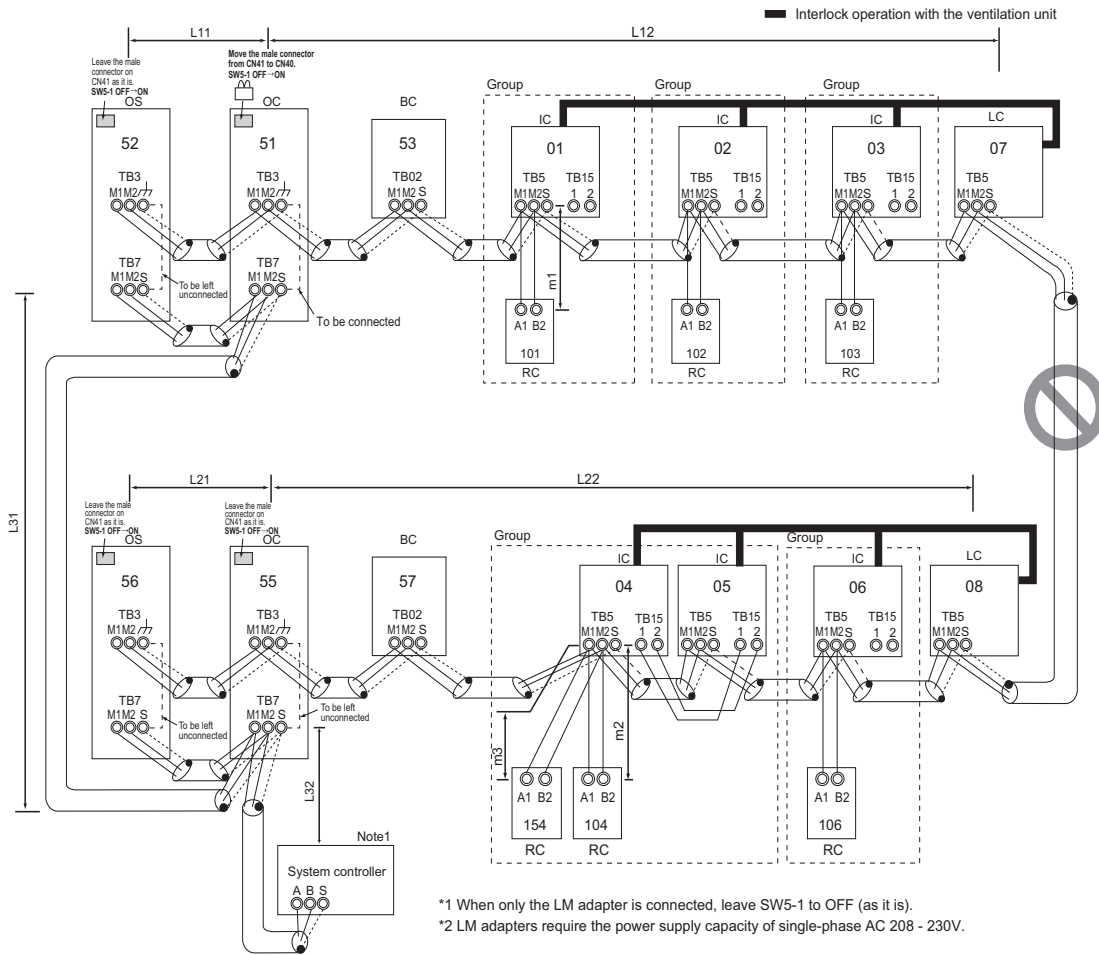

(2) Cautions

- 1) ME remote controller and MA remote controller cannot both be connected to the same group of indoor units.
- 2) No more than 3 ME remote controllers can be connected to a group of indoor units.
- 3) Do not connect the terminal blocks (TB5) on the indoor units that are connected to different heat source units with each other.
- 4) Replace the power jumper connector of the control board from CN41 to CN40 on only one of the heat source units.
- 5) Provide an electrical path to ground for the S terminal on the terminal block for centralized control on only one of the heat source units.
- 6) When the number of the connected indoor units is as shown in the table below, one or more transmission boosters (sold separately) are required.
To connect two transmission boosters, connect them in parallel. (Observe the maximum number of connectable indoor units that are listed in the specifications for each heat source unit.)

	Number of transmission booster (sold separately) required		
	1 unit	2 units	3 units
When the P72 and P96 models are not included in the connected indoor units	15 - 34 units	35 - 50 units	-
When the P72 or P96 model is included in the connected indoor units	11 - 26 units	27 - 42 units	43 - 50 units

- The left table shows the number of transmission boosters that is required by the system with three BC controllers. For each BC controller that is subtracted from the above-mentioned system, two additional indoor units can be connected.
 - Refer to the DATABOOK for further information about how many booster units are required for a given system.
- 7) When a power supply unit is connected to the transmission line for centralized control, leave the power jumper connector on CN41 as it is (factory setting).

(3) Maximum allowable length

- 1) Indoor-heat source transmission line
Same as [5] 8.
- 2) Transmission line for centralized control
Same as [5] 9.
- 3) ME remote controller wiring

Maximum overall line length
(0.3 to 1.25mm² [AWG22 to 16])
m1 ≤ 10m [32ft]
m2+m3 ≤ 10m [32ft]

If the standard-supplied cable must be extended, use a cable with a diameter of 1.25mm² [AWG16]. The section of the cable that exceeds 10m [32ft] must be included in the maximum indoor-heat source transmission line distance described in (1).

When connected to the terminal block on the Simple remote controller, use cables that meet the following cable size specifications: 0.75 - 1.25 mm² [AWG18-16].

- 4) Maximum line distance via heat source unit (1.25 mm² [AWG16] or large)
Same as [5] 9.

(4) Wiring method

- 1) Indoor-heat source transmission line
Same as [5] 8.
Shielded cable connection
Same as [5] 6.
- 2) Transmission line for centralized control
Same as [5] 9.
Shielded cable connection
Same as [5] 9.
- 3) ME remote controller wiring
ME remote controller is connectable anywhere on the indoor-heat source transmission line.

When 2 remote controllers are connected to the system

- Refer to the section on Switch Setting.
Performing a group operation (including the group operation of units in different refrigerant circuits).
Refer to the section on Switch Setting.
- 4) LOSSNAY connection
Same as [5] 9.
 - 5) Switch setting
Address setting is required as follows.

(5) Address setting method

Procedures	Unit or controller			Address setting range	Setting method	Notes	Factory setting
1	Indoor unit	Main unit	IC	01 to 50	<ul style="list-style-type: none"> •Assign the smallest address to the main unit in the group. •In a system with a sub BC controller, make the settings for the indoor units in the following order. <ul style="list-style-type: none"> (i) Indoor unit to be connected to the main BC controller (ii) Indoor unit to be connected to sub BC controller 1 (iii) Indoor unit to be connected to sub BC controller 2 Make the settings for the indoor units in the way that the formula "(i) < (ii) < (iii)" is true. 	<ul style="list-style-type: none"> •Port number setting is required •To perform a group operation of indoor units that have different functions, set the indoor unit in the group with the greatest number of functions as the main unit. 	00
		Sub unit					
2	LOSSNAY		LC	01 to 50	Assign an arbitrary but unique address to each of these units after assigning an address to all indoor units.	None of these addresses may overlap any of the indoor unit addresses.	00
3	ME remote controller	Main remote controller	RC	101 to 150	Add 100 to the main unit address in the group	<ul style="list-style-type: none"> •It is not necessary to set the 100s digit. •To set the address to 200, set the rotary switches to 00. 	101
		Sub remote controller	RC	151 to 200	Add 150 to the main unit address in the group		
4	Heat source unit		OC OS	51 to 100	<ul style="list-style-type: none"> •Assign sequential address to the heat source units in the same refrigerant circuit. •The heat source units are automatically designated as OC and OS.(Note) 	<ul style="list-style-type: none"> •To set the address to 100, set the rotary switches to 50. •If the addresses that is assigned to the main BC controller overlaps any of the addresses that are assigned to the heat source units or to the sub BC controller, use a different, unused address within the setting range. 	00
5	Auxiliary heat source unit	BCcontroller (Sub)	BS	51 to 100	Assign an address that equals the sum of the smallest address of the indoor units that are connected to the sub BC controller and 50.	<ul style="list-style-type: none"> •The use of a sub BC controller requires the connection of a main BC controller. 	
		BC controller (Main)	BC		OC (or OS if it exists) +1		

Note

The heat source units in the same refrigerant circuit are automatically designated as OC and OS. They are designated as OC and OS in the descending order of capacity (ascending order of address if the capacities are the same).

[7] An Example of a System to which both MA Remote Controller and ME Remote Controller are connected

1. PQHY

(1) Sample control wiring

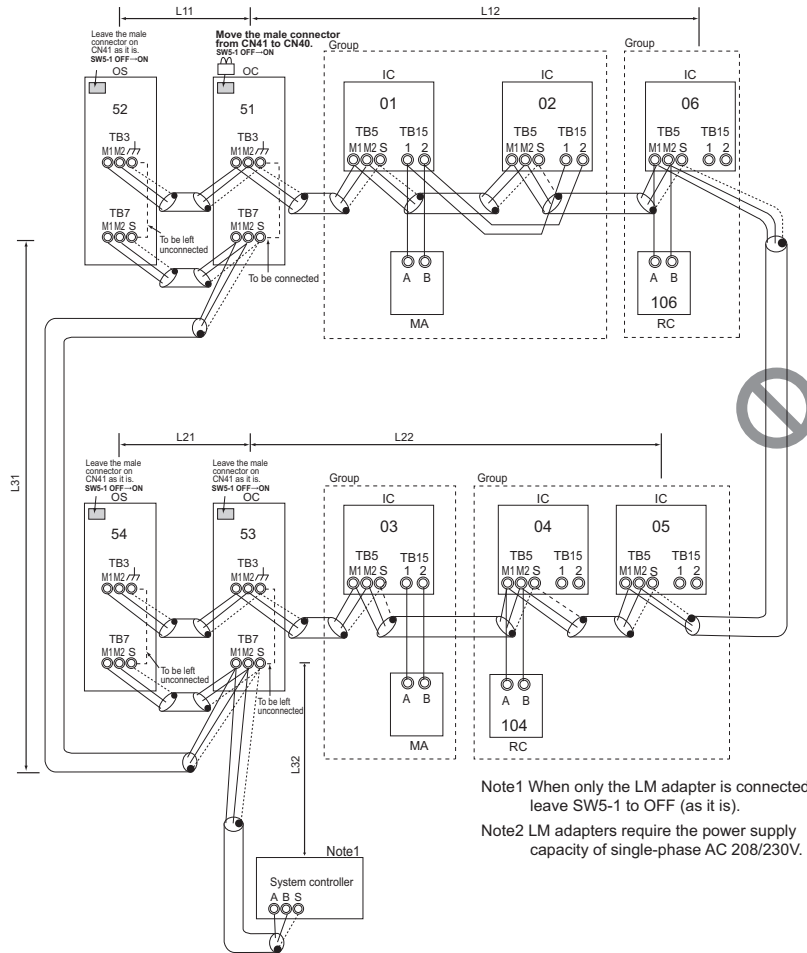

(2) Cautions

- 1) Be sure to connect a system controller.
 - 2) ME remote controller and MA remote controller cannot both be connected to the same group of indoor units.
 - 3) Assign to the indoor units connected to the MA remote controller addresses that are smaller than those of the indoor units that are connected to the ME remote controller.
 - 4) No more than 2 ME remote controllers can be connected to a group of indoor units.
 - 5) No more than 2 MA remote controllers can be connected to a group of indoor units.
 - 6) Do not connect the terminal blocks (TB5) on the indoor units that are connected to different heat source units with each other.
 - 7) Replace the power jumper connector of the control board from CN41 to CN40 on only one of the heat source units.
 - 8) Provide an electrical path to ground for the S terminal on the terminal block for centralized control on only one of the heat source units.
 - 9) A transmission booster must be connected to a system in which the total number of connected indoor units exceeds 20.
 - 10) A transmission booster is required in a system to which more than 16 indoor including one or more indoor units of the 72 model or above are connected.
- ♦Refer to the DATABOOK for further information about how many booster units are required for a given system.

- 11) When a power supply unit is connected to the transmission line for centralized control, leave the power jumper connector on CN41 as it is (factory setting).

(3) Maximum allowable length

- 1) Indoor-heat source transmission line
Same as [5] 3.
- 2) Transmission line for centralized control
Same as [5] 4.
- 3) MA remote controller wiring
Same as [5] 1.
- 4) ME remote controller wiring
Same as [5] 1.
- 5) Maximum line distance via heat source unit (1.25mm² or larger)
Same as [5] 4.

(4) Wiring method

- 1) Indoor-heat source transmission line
Same as [5] 1.
Shielded cable connection
Same as [5] 1.
- 2) Transmission line for centralized control
Same as [5] 4.
Shielded cable connection
Same as [5] 4.
- 3) MA remote controller wiring
Same as [5] 1.
When 2 remote controllers are connected to the system

- Same as [5] 1.
Group operation of indoor units
Same as [5] 1.
- 4) ME remote controller wiring
Same as [6]
When 2 remote controllers are connected to the system
Same as [6]
Group operation of indoor units
Same as [6]
- 5) LOSSNAY connection
Same as [5] 4.
- 6) Switch setting
Address setting is required as follows.

(5) Address setting method

Procedures	Unit or controller			Address setting range	Setting method	Notes	Factory setting			
1	Operation with the MA remote controller	In-door unit	Main unit	IC	01 to 50	Assign the smallest address to the main unit in the group. Assign sequential numbers starting with the address of the main unit in the same group +1. (Main unit address +1, main unit address +2, main unit address +3, etc.)	<ul style="list-style-type: none"> •Assign an address smaller than that of the indoor unit that is connected to the ME remote controller. •Enter the same indoor unit group settings on the system controller as the ones that were entered on the MA remote controller. •To perform a group operation of indoor units that have different functions, designate the indoor unit in the group with the greatest number of functions as the main unit. 	00		
			Sub unit							
		MA remote controller	Main remote controller	MA	No settings required.	-			Main	
			Sub remote controller	MA	Sub remote controller	Settings to be made according to the remote controller function selection				
2	Operation with the ME remote controller	In-door unit	Main unit	IC	01 to 50	Assign the smallest address to the main unit in the group. Assign sequential numbers starting with the address of the main unit in the same group +1. (Main unit address +1, main unit address +2, main unit address +3, etc.)	<ul style="list-style-type: none"> •Enter the indoor unit group settings on the system controller (MELANS). •Assign an address larger than those of the indoor units that are connected to the MA remote controller. •To perform a group operation of indoor units that have different functions, designate the indoor unit in the group with the greatest number of functions as the main unit. 	00		
			Sub unit							
		ME remote controller	Main remote controller	RC	101 to 150	Add 100 to the main unit address in the group.			<ul style="list-style-type: none"> •It is not necessary to set the 100s digit. •To set the address to 200, set the rotary switches to 00. 	101
			Sub remote controller	RC	151 to 200	Add 150 to the main unit address in the group.				
3	LOSSNAY			LC	01 to 50	Assign an arbitrary but unique address to each of these units after assigning an address to all indoor units.	None of these addresses may overlap any of the indoor unit addresses.	00		
4	Heat source unit			OC OS	51 to 100	Assign sequential address to the heat source units in the same refrigerant circuit. The heat source units are automatically designated as OC and OS.(Note)	To set the address to 100, set the rotary switches to 50.	00		

Note

The heat source units in the same refrigerant circuit are automatically designated as OC and OS.

2. PQR

(1) Sample control wiring

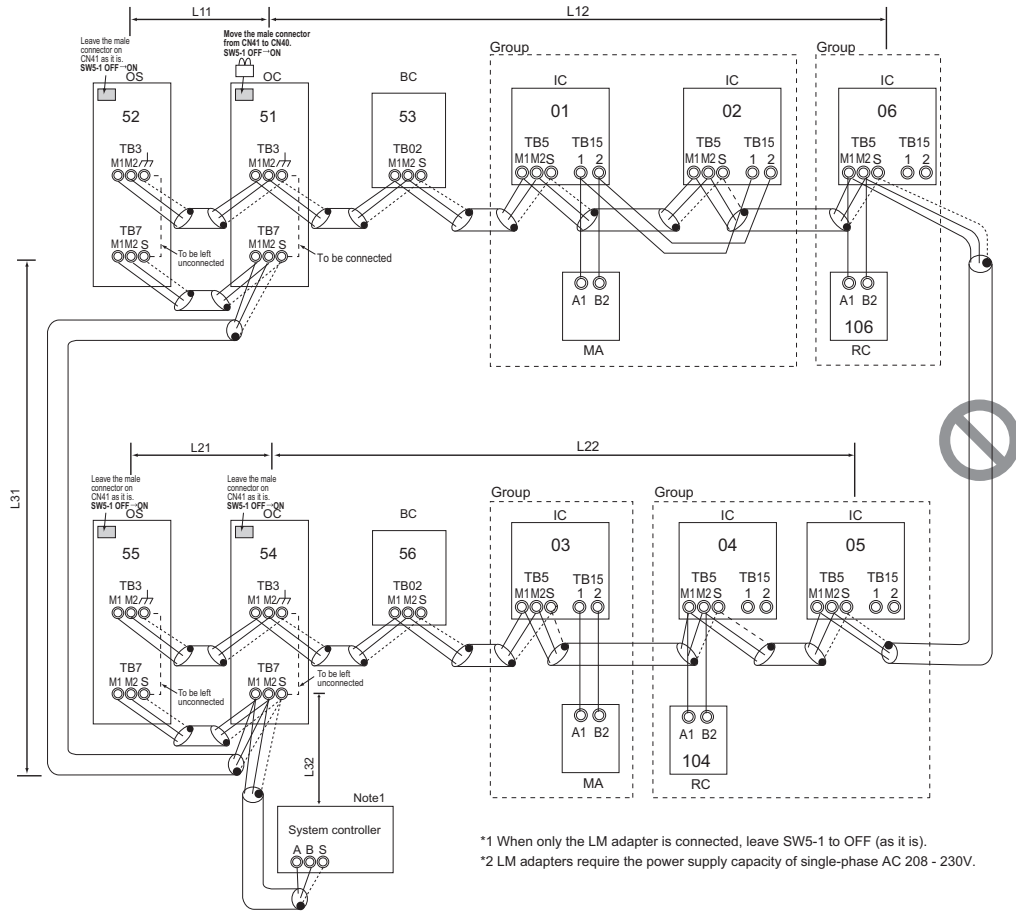

(2) Cautions

- 1) Be sure to connect a system controller.
- 2) ME remote controller and MA remote controller cannot both be connected to the same group of indoor units.
- 3) Assign to the indoor units connected to the MA remote controller addresses that are smaller than those of the indoor units that are connected to the ME remote controller.
- 4) No more than 2 ME remote controllers can be connected to a group of indoor units.
- 5) No more than 2 MA remote controllers can be connected to a group of indoor units.
- 6) Do not connect the terminal blocks (TB5) on the indoor units that are connected to different heat source units with each other.
- 7) Replace the power jumper connector of the control board from CN41 to CN40 on only one of the heat source units.
- 8) Provide an electrical path to ground for the S terminal on the terminal block for centralized control on only one of the heat source units.
- 9) When the number of the connected indoor units is as shown in the table below, one or more transmission boosters (sold separately) are required.
To connect two transmission boosters, connect them in parallel.
(Observe the maximum number of connectable indoor units that are listed in the specifications for each heat source unit.)

	Number of transmission booster (sold separately) required		
	1 unit	2 units	3 units
When the P72 and P96 models are not included in the connected indoor units	15 - 34 units	35 - 50 units	-
When the P72 or P96 model is included in the connected indoor units	11 - 26 units	27 - 42 units	43 - 50 units

- The left table shows the number of transmission boosters that is required by the system with three BC controllers. For each BC controller that is subtracted from the above-mentioned system, two additional indoor units can be connected.
 - Refer to the DATABOOK for further information about how many booster units are required for a given system.
- 10) When a power supply unit is connected to the transmission line for centralized control, leave the power jumper connector on CN41 as it is (factory setting).

(3) Maximum allowable length

- 1) Indoor-heat source transmission line
Same as [5] 8.
- 2) Transmission line for centralized control
Same as [5] 9.
- 3) MA remote controller wiring
Same as [5] 6.
- 4) ME remote controller wiring
Same as [6] 2.
- 5) Maximum line distance via heat source unit (1.25 mm² or larger)
Same as [5] 4.

(4) Wiring method

- 1) Indoor-heat source transmission line
Same as [5] 8.

Shielded cable connection

Same as [5] 6.

- 2) Transmission line for centralized control
Same as [5] 9.

Shielded cable connection

Same as [5] 9.

- 3) MA remote controller wiring

When 2 remote controllers are connected to the system

Group operation of indoor units

Same as [5] 6.

- 4) ME remote controller wiring

When 2 remote controllers are connected to the system

Group operation of indoor units

Same as [6] 1.

- 5) LOSSNAY connection

Same as [5] 9.

- 6) Switch setting

Address setting is required as follows.

(5) Address setting method

Proce- dure s	Unit or controller				Ad- dress set- ting range	Setting method	Notes	Facto- ry set- ting
1	Opera- tion with the MA re- mote controller	In- door unit	Main unit	IC	01 to 50	<ul style="list-style-type: none"> Assign the smallest address to the main unit in the group. In a system with a sub BC controller, make the settings for the indoor units in the following order. <ul style="list-style-type: none"> (i) Indoor unit to be connected to the main BC controller (ii) Indoor unit to be connected to sub BC controller 1 (iii) Indoor unit to be connected to sub BC controller 2 Make the settings for the indoor units in the way that the formula "(i) < (ii) < (iii)" is true.	<ul style="list-style-type: none"> Assign an address smaller than that of the indoor unit that is connected to the ME remote controller. Enter the same indoor unit group settings on the system controller as the ones that were entered on the MA remote controller. To perform a group operation of indoor units that have different functions, designate the indoor unit in the group with the greatest number of functions as the main unit. Port number setting is required 	00
			Sub unit	IC	01 to 50			
	MA re- mote con- troller	Main re- mote con- troller	MA	No set- tings re- quired.	-	Main		
		Sub re- mote con- troller	MA	Sub re- mote con- troller	Settings to be made according to the remote controller function selection			
2	Opera- tion with the ME re- mote controller	In- door unit	Main unit	IC	01 to 50	Assign the smallest address to the main unit in the group.	<ul style="list-style-type: none"> Assign an address higher than those of the indoor units that are connected to the MA remote controller. Make the initial settings for the indoor unit group settings via the system controller. To perform a group operation of indoor units that have different functions, designate the indoor unit in the group with the greatest number of functions as the main unit. Port number setting is required. Addresses that are assigned to the indoor units that are connected to the sub BC controller should be higher than the addresses that are assigned to the indoor units that are connected to the main BC controller. 	00
			Sub unit	IC	01 to 50	Assign sequential numbers starting with the address of the main unit in the same group +1. (Main unit address +1, main unit address +2, main unit address +3, etc.)		
	ME re- mote con- troller	Main re- mote con- troller	RC	101 to 150	Add 100 to the main unit address in the group.	<ul style="list-style-type: none"> It is not necessary to set the 100s digit. To set the address to 200, set it to 00. 	101	
		Sub re- mote con- troller	RC	151 to 200	Add 150 to the main unit address in the group.			
3	LOSSNAY			LC	01 to 50	Assign an arbitrary but unique address to each of these units after assigning an address to all indoor units.	None of these addresses may overlap any of the indoor unit addresses.	00
4	Heat source unit			OC OS	51 to 100	<ul style="list-style-type: none"> Assign sequential address to the heat source units in the same refrigerant circuit. The heat source units are automatically designated as OC and OS. (Note) 	<ul style="list-style-type: none"> To set the address to 100, set it to 50. If the addresses that is assigned to the main BC controller overlaps any of the addresses that are assigned to the heat source units or to the sub BC controller, use a different, unused address within the setting range. 	00
5	Auxiliary heat source unit	BCcontroller (Sub)	BS	51 to 100	Assign an address that equals the sum of the smallest address of the indoor units that are connected to the sub BC controller and 50.	<ul style="list-style-type: none"> The use of a sub BC controller requires the connection of a main BC controller. 		
		BC controller (Main)	BC		OC (or OS if it exists) +1			

Note

The heat source units in the same refrigerant circuit are automatically designated as OC and OS. They are designated as OC and OS in the descending order of capacity (ascending order of address if the capacities are the same).

[8] Restrictions on Pipe Length

(1) End branching <PQHY>

P72 - P240 models

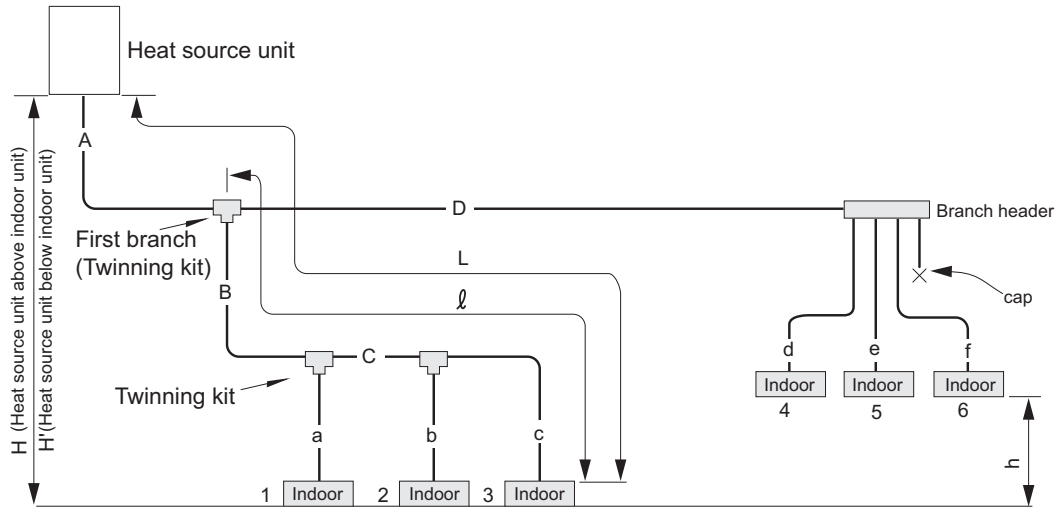

Unit: m [ft]

Operation		Pipe sections	Allowable length of pipes	
Length	Total pipe length	$A+B+C+D + a+b+c+d+e+f$	P72-P120 300 [984] or less P144-P240 500 [1640] or less	
	Total pipe length (L) from the heat source unit to the farthest indoor unit	$A+B+C+c$ or $A+D+f$	165 [541] or less (Equivalent length 190 [623] or less)	
	Total pipe length from the first branch to the farthest indoor unit (l)	$B+C+c$ or $D+f$	40 [131] or less ^{*1}	
Height difference	Between indoor and heat source units	Heat source unit above indoor unit	H	50 [164] or less
		Heat source unit below indoor unit	H'	40 [131] or less
	Between indoor units	h	15 [49] or less	

*1. If the piping length exceeds 40 meters (but does not exceed 90 meters), use one-size larger pipes for indoor unit liquid pipes.

P144 - P360 models

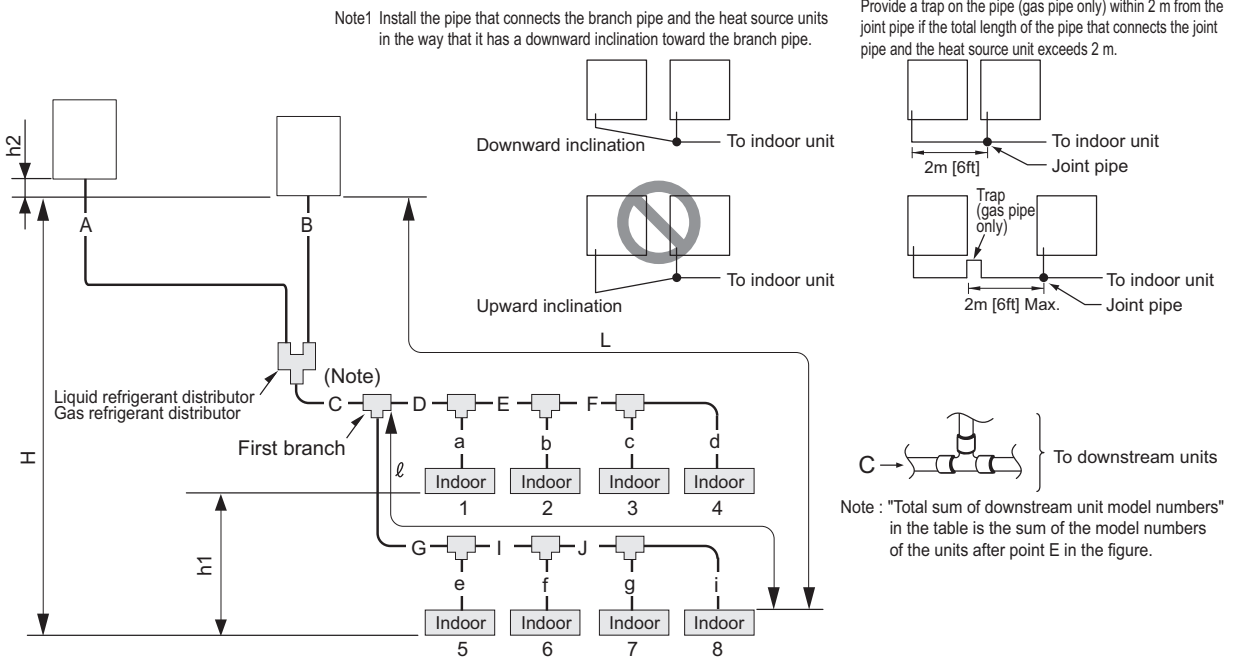

Operation		Pipe sections	Allowable length of pipes
Length	Between heat source units	A+B	10 [32] or less
	Total pipe length	A+B+C+D+E+F+G+I+J +a+b+c+d+e+f+g+i	500 [1640] or less
	Total pipe length (L) from the heat source unit to the farthest indoor unit	A+C+G+I+J	165 [541] or less (Equivalent length 190 [623] or less)
	Total pipe length from the first branch to the farthest indoor unit (l)	G+I+J+i	40 [131] or less ^{*1}
Height difference	Between indoor and heat source units	H	50 [164] or less (40 [131] or below if heat source unit is below indoor unit)
	Between indoor units	h1	15 [49] or less
	Between heat source units	h2	0.1[0.3] or less

*1. If the piping length exceeds 40 meters (but does not exceed 90 meters), use one-size larger pipes for indoor unit liquid pipes.

1. Refrigerant pipe size <PQHY>**(1) Diameter of the refrigerant pipe between the heat source unit and the first branch (heat source unit pipe size)**

Heat source unit set name	Liquid pipe size (mm) [inch]	Gas pipe size (mm) [inch]
P72 model	ø9.52 [3/8"]	ø19.05 [3/4"]
P96 model	ø9.52 [3/8"]* ¹	ø22.2 [7/8"]
P120 model	ø9.52 [3/8"]* ²	ø22.2 [7/8"]
P144 model	ø12.7 [1/2"]	ø28.58 [1-1/8"]
P168 - 240 model	ø15.88 [5/8"]	ø28.58 [1-1/8"]
P264 - 312models	ø19.05 [3/4"]	ø34.93 [1-3/8"]
P336 - 360 models	ø19.05 [3/4"]	ø41.28 [1-5/8"]

*1. Use ø12.7 [1/2"] pipes if the piping length exceeds 90 m [295 ft].

*2. Use ø12.7 [1/2"] pipes if the piping length exceeds 40 m [131 ft].

(2) Size of the refrigerant pipe between the first branch and the indoor unit (indoor unit pipe size)

Indoor unit model	Pipe diameter (mm) [inch]	
06 - 15 models	Liquid pipe	ø6.35 [1/4"]
	Gas pipe	ø12.7 [1/2"]
18 - 54 models	Liquid pipe	ø9.52 [3/8"]
	Gas pipe	ø15.88 [5/8"]
72 model	Liquid pipe	ø9.52 [3/8"]
	Gas pipe	ø19.05 [3/4"]
96 model	Liquid pipe	ø9.52 [3/8"]
	Gas pipe	ø22.2 [7/8"]

(3) Size of the refrigerant pipe between the branches for connection to indoor units

Total capacity of the downstream units	Liquid pipe size (mm) [inch]	Gas pipe size (mm) [inch]
- 54	ø9.52 [3/8"]	ø15.88 [5/8"]
P55 - P72	ø9.52 [3/8"]	ø19.05 [3/4"]
P72 - P108	ø9.52 [3/8"]	ø22.2 [7/8"]
P109 - P144	ø12.7 [1/2"]	ø28.58 [1-1/8"]
P145 - P240	ø15.88 [5/8"]	ø28.58 [1-1/8"]
P241 - P308	ø19.05 [3/4"]	ø34.93 [1-3/8"]
P309 -	ø19.05 [3/4"]	ø41.28 [1-5/8"]

(4) Size of the refrigerant pipe between the distributor and heat source units

Heat source unit model	Composing unit models	Liquid pipe (mm) [inch]	Gas pipe (mm) [inch]
P144	P72	ø9.52 [3/8"]	ø19.05 [3/4"]
	P72		
P168	P96	ø9.52 [3/8"]	ø22.2 [7/8"]
	P72		
P192	P96	ø9.52 [3/8"]	ø22.2 [7/8"]
	P96		
P216	P120	ø12.7 [1/2"]	ø22.2 [7/8"]
	P96		
P240	P120	ø12.7 [1/2"]	ø22.2 [7/8"]
	P120		
P288	P144	ø12.7 [1/2"]	ø28.58 [1-1/8"]
	P144		
P312	P168	ø15.88 [5/8"]	ø28.58 [1-1/8"]
	P144		
P336	P168	ø15.88 [5/8"]	ø28.58 [1-1/8"]
	P168		
P360	P192	ø15.88 [5/8"]	ø28.58 [1-1/8"]
	P168		

(1) System that requires 16 BC controller ports or fewer <System with only the main BC controller or standard BC controller> <PQRY>

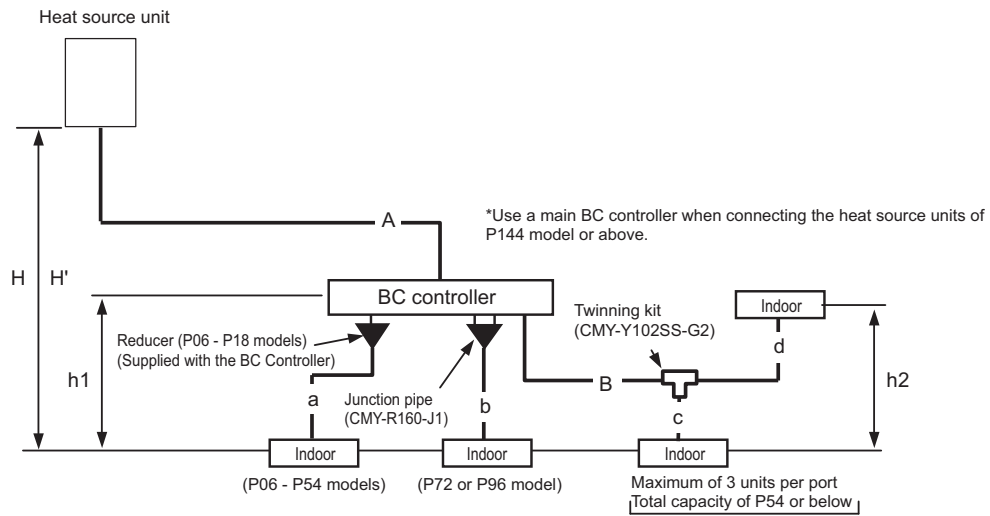

Unit: m [ft]

Operation		Pipe sections	Allowable length of pipes
Length	Total pipe length	A+B+a+b+c+d	Refer to the restrictions on the total piping length in the graph on the next page.
	Total pipe length from the heat source unit to the farthest indoor unit	A+B+d	165 [541] or less (Equivalent length 190 [623] or less)
	Between heat source unit and BC controller	A	110 [360] or less
	Between BC controller and indoor unit	B+d	40 [131] or less ^{*1}
Height difference	Between indoor unit and heat source units	Heat source unit above indoor unit	50 [164] or less
		Heat source unit below indoor unit	40 [131] or less
	Between indoor unit and BC controller	h1	15[49](10[32]) or less ^{*2}
	Between indoor units	h2	30[98](10[32]) or less ^{*2}

*1. When the overall pipe length between the BC controller and the farthest indoor unit exceeds 40m [131ft], observe the restrictions in the figure titled "Restrictions on pipe length" below (except the P96 model).

*2. When the capacity of the connected indoor units is P72 or above, use the figures in the parentheses as a reference.

Note

- 1) To connect the P72 or P96 model of indoor units, use an optional junction pipe kit (Model: CMY-R160-J1) and merge the two ports before connecting them.
- 2) Do not connect the P72 or P96 model of indoor units and other models of indoor units at the same port.
- 3) All the units that are connected to the same ports can only be operated in the same operation mode (cooling/heating).

■ Restrictions on pipe length

[PQRY-P72, P96, P120TLMU-A/YLMU-A1]

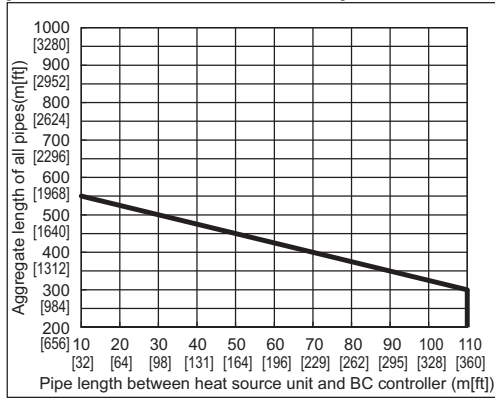

■ The height difference and the pipe length between BC controller and indoor units

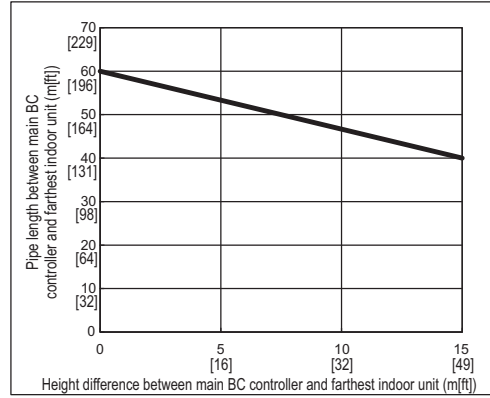

■ Restrictions on pipe length

[PQRY-P144, P168, P192, P216, P240TLMU-A/YLMU-A1]

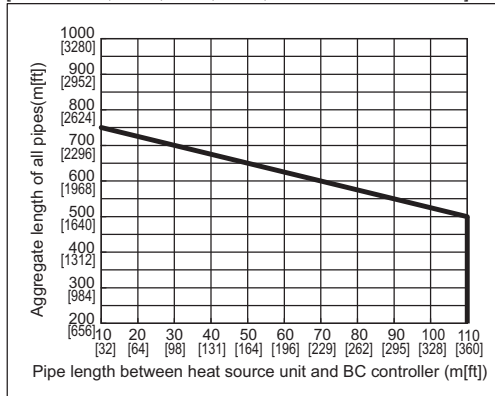

■ The height difference and the pipe length between BC controller and indoor units

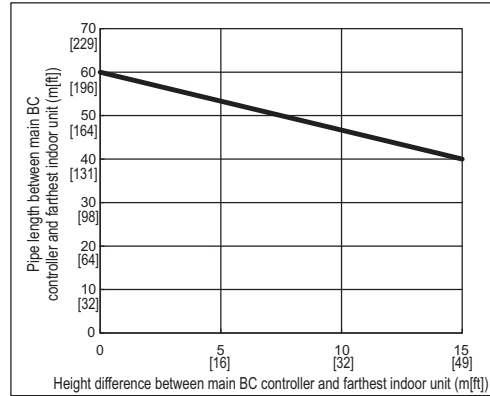

(2) System that requires more than 16 BC controller ports or with multiple BC controllers <Heat source unit P120 model or below>

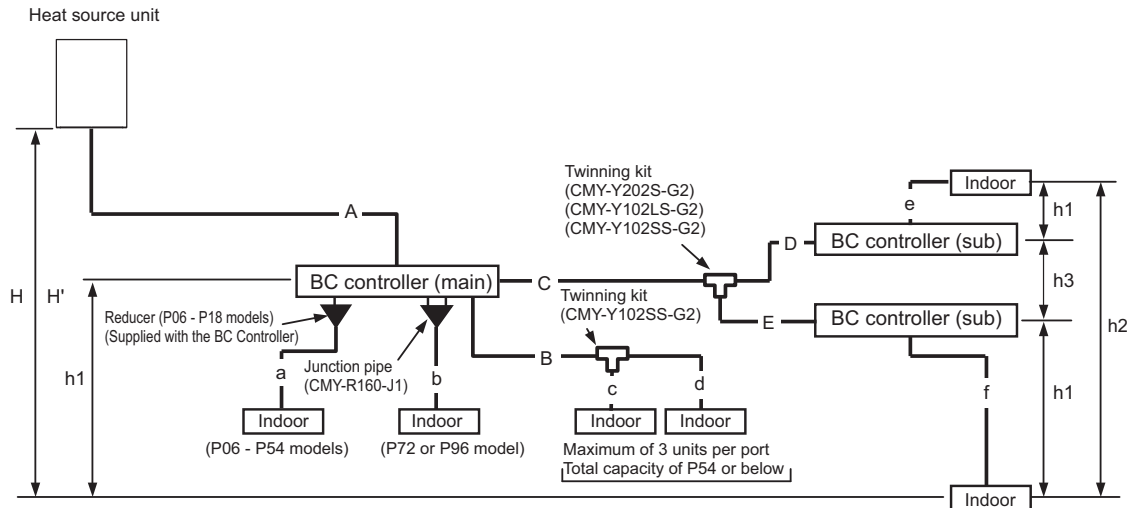

Unit: m [ft]

Operation		Pipe sections	Allowable length of pipes
Length	Total pipe length		A+B+C+D+E+a+b+c+d+e+f
	Total pipe length from the heat source unit to the farthest indoor unit		A+C+E+f
	Between heat source unit and BC controller		A
	Between BC controller and indoor unit		B+d or C+D+e or C+E+f
Height difference	Between indoor and heat source units	Heat source unit above indoor unit	H
		Heat source unit below indoor unit	H'
	Between indoor unit and BC controller		h1
	Between indoor units		h2
	Between the BC controller (main or sub) and the sub BC controller		h3

*1. When the overall pipe length between the BC controller and the farthest indoor unit exceeds 40m [131ft], observe the restrictions in the figure titled "Restrictions on pipe length" below (except the P96 model).

*2. When the capacity of the connected indoor units is P72 or above, use the figures in the parentheses as a reference.

Note

- 1) A system that requires more than 16 BC controller ports requires two or three BC controllers (main and sub), and three pipes will be used between the main and the sub BC controllers.
- 2) When connecting two sub BC controllers, observe the maximum allowable length in the table above.
- 3) When connecting two sub BC controllers, install them in parallel.
- 4) To connect the P72 or P96 model of indoor units, use an optional junction pipe kit (Model: CMY-R160-J1) and merge the two ports before connecting them.
- 5) Do not connect the P72 or P96 model of indoor units and other models of indoor units at the same port.
- 6) All the units that are connected to the same ports can only be operated in the same operation mode (cooling/heating).
- 7) The maximum capacity of the indoor units that is connectable to the CMB-P-NU-GB types of sub BC controllers is P126 or below (when two GB type controllers are connected P126 or below for both combined).
 The maximum total capacity of indoor units that is connectable to the sub BC controller CMB-P1016NU-HB is P126 or below. If at least one CMB-P1016NU-HB unit is connected, the maximum total capacity of connectable indoor units to a system with two sub controllers is P168 or below.

■ Restrictions on pipe length

[PQRYP-72, P96, P120TLMU-A/YLMU-A1]

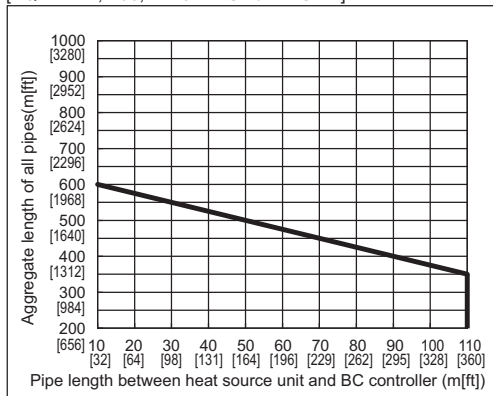

■ The height difference and the pipe length between BC controller and indoor units

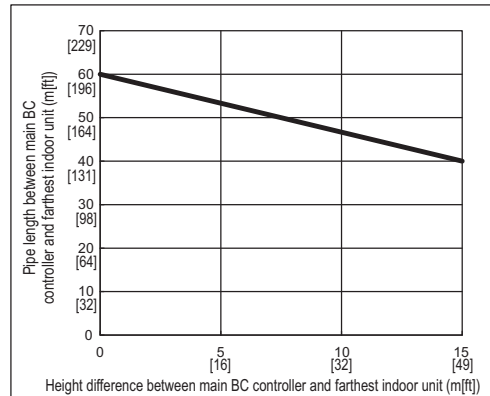

■ Restrictions on pipe length

[PQRYP-144, P168, P192, P216, P240TLMU-A/YLMU-A1]

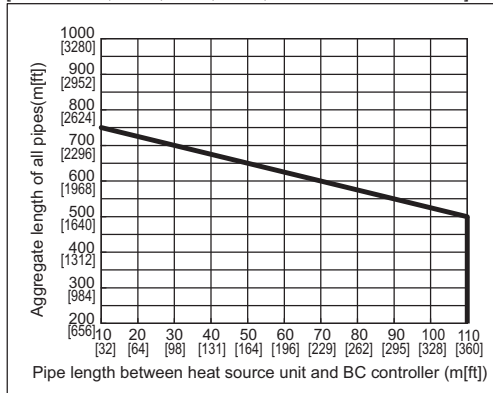

■ The height difference and the pipe length between BC controller and indoor units

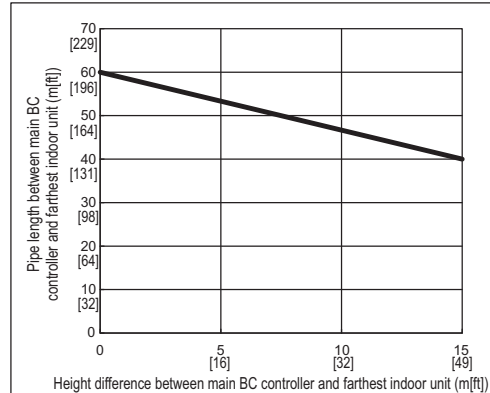

(3) System that requires more than 16 BC controller ports or with multiple BC controllers <Heat source unit P144 model or above>

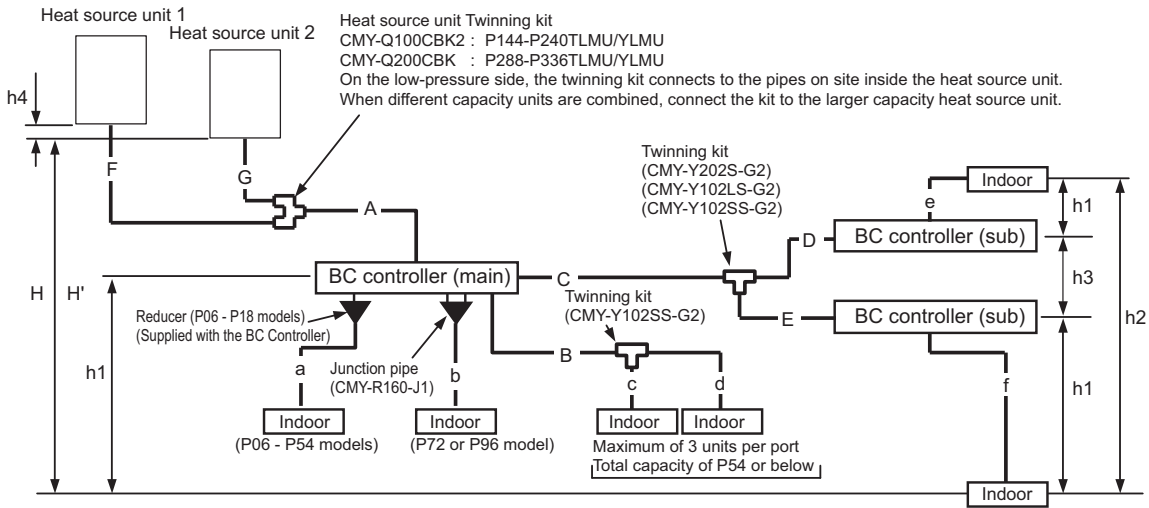

Unit: m [ft]

Operation		Pipe sections	Allowable length of pipes	
Length	Total pipe length	$F+G+A+B+C+D+E+a+b+c+d+e+f$	Refer to the restrictions on the total piping length in the graph on the next page.	
	Total pipe length from the heat source unit to the farthest indoor unit	$F(G)+A+C+E+f$	165 [541] or less (Equivalent length 190 [623] or less)	
	Between heat source unit and BC controller	$F(G)+A$	110 [360] or less	
	Between BC controller and indoor unit	$B+d$ or $C+D+e$ or $C+E+f$	40 [131] or less ^{*1}	
	Between heat source units	$F+G$	5 [16] or less	
Height difference	Between indoor and heat source units	Heat source unit above indoor unit	H	50 [164] or less
		Heat source unit below indoor unit	H'	40 [131] or less
	Between indoor unit and BC controller	h1	15 [49](10[32]) or less ^{*2}	
	Between indoor units	h2	30 [98](10[32]) or less ^{*2}	
	Between the BC controller (main or sub) and the sub BC controller	h3	15 [49] or less	
	Between heat source units	h4	0.1 [0.3] or less	

*1. When the overall pipe length between the BC controller and the farthest indoor unit exceeds 40m [131ft], observe the restrictions in the figure titled "Restrictions on pipe length" below (except the P96 model).

*2. When the capacity of the connected indoor units is P72 or above, use the figures in the parentheses as a reference.

Note

- 1) A system that requires more than 16 BC controller ports requires two or three BC controllers (main and sub), and three pipes will be used between the main and the sub BC controllers.
- 2) When connecting two sub BC controllers, observe the maximum allowable length in the table above.
- 3) When connecting two sub BC controllers, install them in parallel.
- 4) To connect the P72 or P96 model of indoor units, use an optional junction pipe kit (Model: CMY-R160-J1) and merge the two ports before connecting them.
- 5) Do not connect the P72 or P96 model of indoor units and other models of indoor units at the same port.
- 6) All the units that are connected to the same ports can only be operated in the same operation mode (cooling/heating).
- 7) The maximum capacity of the indoor units that is connectable to the CMB-P-NU-GB types of sub BC controllers is P126 or below (when two GB type controllers are connected, P126 or below for both combined).
 The maximum total capacity of indoor units that is connectable to the sub BC controller CMB-P1016NU-HB is P126 or below. If at least one CMB-P1016NU-HB unit is connected, the maximum total capacity of connectable indoor units to a system with two sub controllers is P168 or below.

■ Restrictions on pipe length

[PQRY-P144, P168, P192, P216, P240, P288, P312, P336TSLMU-A/YSLMU-A1]

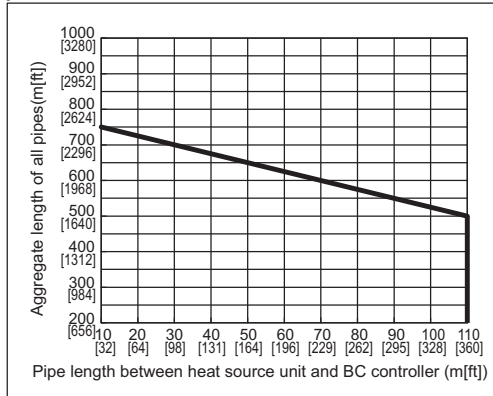

■ The height difference and the pipe length between BC controller and indoor units

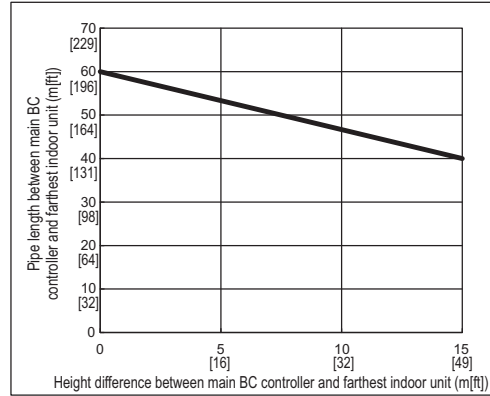

2. Refrigerant pipe size <PQRY>

(1) Between heat source unit and the first twinning pipe (Part A)

Unit : mm [inch]

Heat source unit	Refrigerant pipe size	
	High-pressure pipe	Low-pressure pipe
P72	ø15.88 [5/8"]	ø19.05 [3/4"]
P96	ø19.05 [3/4"]	ø22.2 [7/8"]
P120		
P144 - P192	ø22.2[7/8"]	ø28.58 [1-1/8"]
P216	ø22.2[7/8"]*1	
P240		ø34.93 [1-3/8"]
P288 - P312	ø28.58 [1-1/8"]	ø41.28 [1-5/8"]
P336		

*1. When the piping length exceeds 65 meters [213 ft], use ø28.58 [1-1/8"] pipes for the section of the piping that exceeds 65 meters.

(2) Between BC controller and indoor unit (Sections a, b, c, d, e, and f)

Unit : mm [inch]

Indoor unit	Refrigerant pipe size		Indoor unit connection (Brazed connection for all models)	
	Liquid pipe	Gas pipe	Liquid pipe	Gas pipe
P06, P08, P12, P15, P18	ø6.35 [1/4"]	ø12.7 [1/2"]	ø6.35 [1/4"]	ø12.7 [1/2"]
P24, P27, P30	ø9.52 [3/8"]	ø15.88 [5/8"]	ø9.52 [3/8"]	ø15.88 [5/8"]
P36, P48, P54				
P72	ø9.52 [3/8"]	ø19.05 [3/4"]	ø9.52 [3/8"]	ø19.05 [3/4"]
P96		ø22.2[7/8"]		ø22.2[7/8"]

(3) Between the main and sub BC controllers (Section C)

Unit : mm [inch]

Indoor unit	Refrigerant pipe size (Brazed connection on all models)		
	Liquid pipe	High-pressure gas pipe	Low-pressure gas pipe
- P72	ø9.52 [3/8"]	ø15.88 [5/8"]	ø19.05 [3/4"]
P73 - P108		ø19.05 [3/4"]	ø22.2 [7/8"]
P109 - P126	ø12.7 [1/2"]		ø22.2 [7/8"]
P127 - P144			
P145 - P168	ø15.88 [5/8"]		

Select the proper size pipes for the main unit based on the total capacity of the indoor units that are connected to both sub BC controllers. Select the proper size pipes for the sub controller side based on the total capacity of the indoor units that are connected to the sub controller.

3. Connecting the BC controller <PQRY>

(1) Size of the pipe that fits the standard BC controller ports

P72 - P120 models

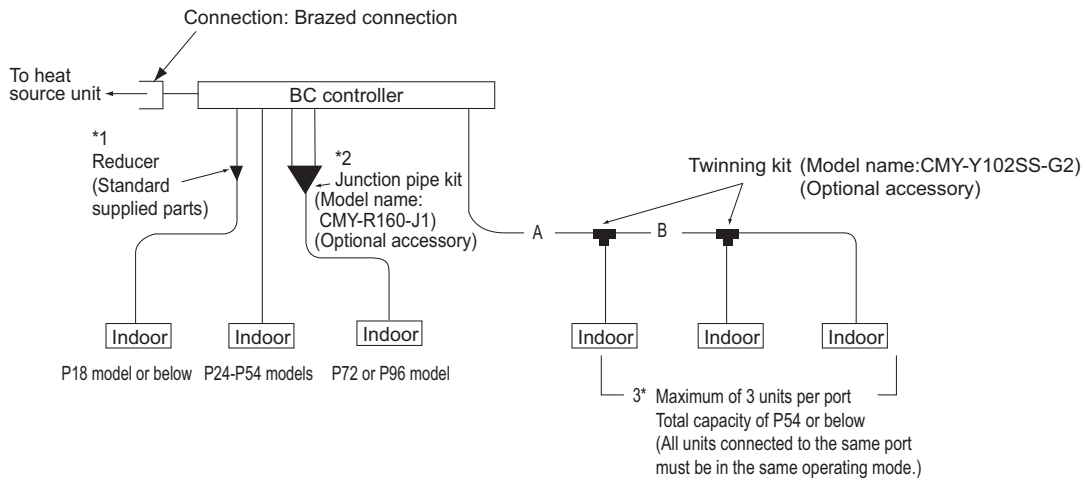

The ports of the BC controller accommodates the pipes on P24-P54 models of indoor units.
To connect other types of indoor units, follow the procedure below.

Unit : mm [inch]

Operation		Pipe sections	
		High-pressure side (liquid)	Low-pressure side (gas)
Heat source unit side	P72	ø15.88 [5/8"] (Brazed connection)	ø19.05 [3/4"] (Brazed connection)
	P96 P120	ø19.05 [3/4"] (Brazed connection)	ø22.2 [7/8"] (Brazed connection)
Indoor unit side		ø9.52 [3/8"] (Brazed connection)	ø15.88 [5/8"] (Brazed connection)

* BC controllers can only be connected to P72 - P120 models of heat source units.

Note

1)

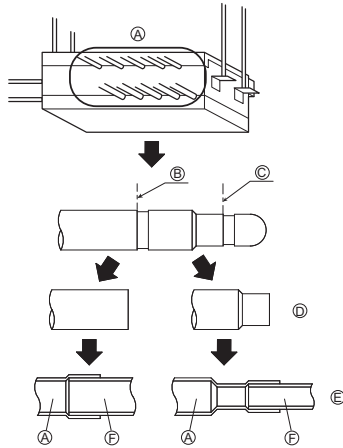

Be sure to have pipe expansion of indoor unit connecting port by cutting the piping at the cutting point which depends on the indoor unit capacity.

- Ⓐ Indoor unit connecting port
- Ⓑ Cutting point : $\phi 9.52$ (Liquid side) or $\phi 15.88$ (Gas side)
(Indoor unit model : bigger than P18)
- Ⓒ Cutting point : $\phi 6.35$ (Liquid side) or $\phi 12.7$ (Gas side)
(Indoor unit model : P18 or smaller)
- Ⓓ Cut the piping at the cutting point
- Ⓔ Have pipe expansion of indoor unit connecting port
- Ⓕ Field pipe

Note:
Remove burr after cutting the piping to prevent entering the piping.
Check that there is no crack at the pipe expansion part.

Note

2) To connect P72 - P96 models of indoor units (or when the total capacity of indoor units exceeds P55), use a junction pipe kit and merge the two nozzles.

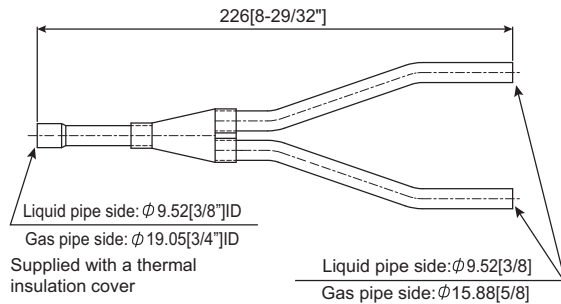

Note

- 3) To connect multiple indoor units to a port (or to a junction pipe)
- Maximum total capacity of connected indoor units: P54 or below (in a system with a junction pipe: P96 or below)
 - Maximum number of connectable indoor units: 3 units
 - Branch joint: Use CMY-Y102SS-G2 (optional accessory).
 - Refrigerant pipe selection (size of the pipes in sections A and B in the figure above): Select the proper size pipes based on the total capacity of the downstream indoor units, using the table below as a reference.

Unit : mm [inch]

Total capacity of indoor units	Liquid pipe	Gas pipe
P54 or below	$\phi 9.52$ [3/8"]	$\phi 15.88$ [5/8"]
P55 - P72	$\phi 9.52$ [3/8"]	$\phi 19.05$ [3/4"]
P73 - P96	$\phi 9.52$ [3/8"]	$\phi 22.2$ [7/8"]

(2) Size of the pipe that fits the main BC controller ports

P72 - P336 models

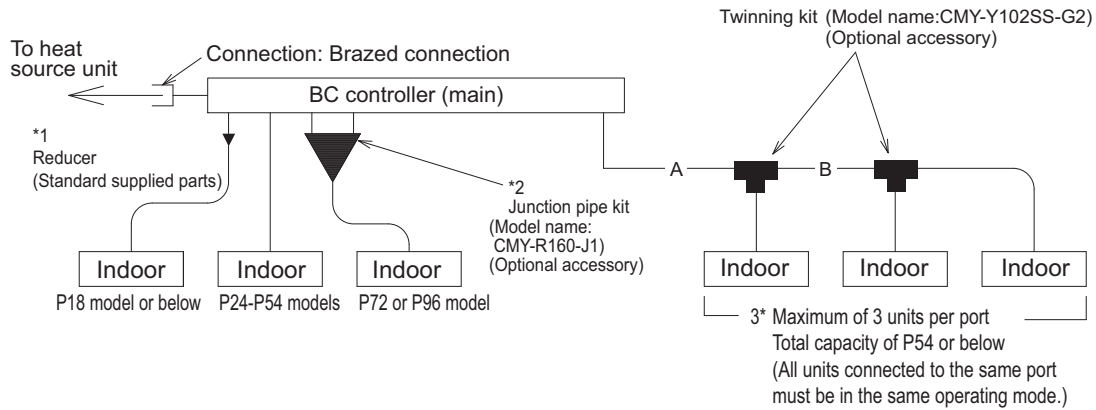

The ports of the BC controller accommodates the pipes on P24-P54 models of indoor units. To connect other types of indoor units, follow the procedure below.

Note

- 1) To connect P06-P18 models of indoor units use the reducer that is supplied with the BC controller.
- 2) To connect the units between the P72 and P96 models of indoor units (or when the total capacity of indoor units is P31 or above), use a junction pipe kit and merge the two nozzles.
- 3) To connect multiple indoor units to a port (or to a junction pipe)
 - Maximum total capacity of connected indoor units: P54 or below (in a system with a junction pipe: P96 or below)
 - Maximum number of connectable indoor units: 3 units
 - Twinning kit: Use CMY-Y102SS-G2 (optional accessory).
 - Refrigerant pipe selection (size of the pipes in sections A and B in the figure above): Select the proper based on the total capacity of the downstream indoor units, using the table below as a reference.

Unit : mm [inch]

Total capacity of indoor units	Liquid pipe	Gas pipe
P54 or below	ø9.52 [3/8"]	ø15.88 [5/8"]
P55 - P72	ø9.52 [3/8"]	ø19.05 [3/4"]
P73 - P96	ø9.52 [3/8"]	ø22.2 [7/8"]

Unit : mm [inch]

Model		Pipe sections	
		High pressure side (Liquid)	Low-pressure side (Gas)
Heat source unit side	P72	ø15.88 [5/8"] (Braze connection)	ø19.05 [3/4"] (Braze connection)
	P96	ø19.05 [3/4"] (Braze connection)s	ø22.2 [7/8"] (Braze connection)
	P120		
	P144	ø22.2 [7/8"] (Braze connection)	ø28.58 [1-1/8"] (Braze connection)
	P168		
	P192		
	P216	ø22.2 [7/8"] *1 (Braze connection)	ø34.93 [1-3/8"] (Braze connection)
	P240		
	P288	ø28.58 [1-1/8"] (Braze connection)	ø41.28 [1-5/8"] (Braze connection)
	P312		
P336			
Indoor unit side		ø9.52 [3/8"] (Braze connection)	ø15.88 [5/8"] (Braze connection)

*1. When the piping length exceeds 65 meters [213 ft], use ø28.58 [1-1/8"] pipes for the section of the piping that exceeds 65 meters.

(3) Size of the pipe that fits the sub BC controller ports

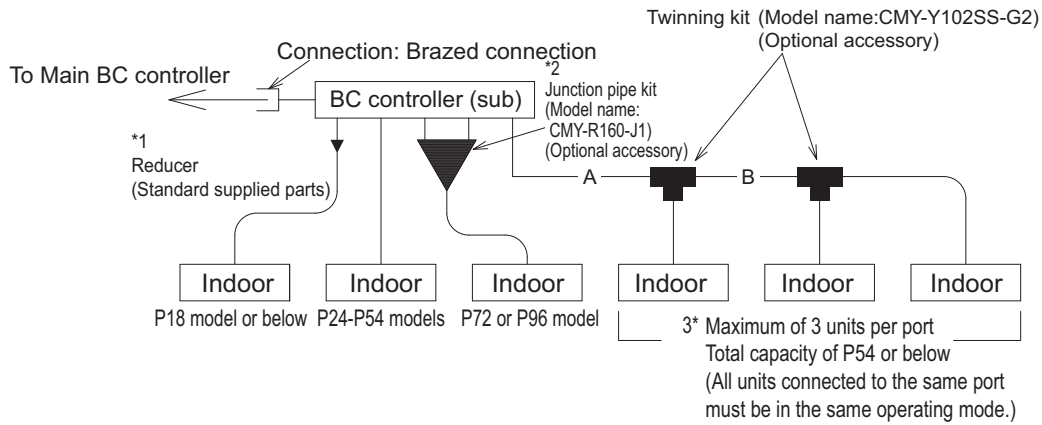

The ports of the BC controller accommodates the pipes on P24-P54 models of indoor units. To connect other types of indoor units, follow the procedure below.

Note

- 1) To connect P06-P18 models of indoor units use the reducer that is supplied with the BC controller.
- 2) To connect the units between the P72 and P96 models of indoor units (or when the total capacity of indoor units is P31 or above), use a junction pipe kit and merge the two nozzles.
- 3) To connect multiple indoor units to a port (or to a junction pipe)
 - Maximum total capacity of connected indoor units: P54 or below (in a system with a junction pipe: P96 or below)
 - Maximum number of connectable indoor units: 3 units
 - Twinning kit: Use CMY-Y102SS-G2 (optional accessory).
 - Refrigerant pipe selection (size of the pipes in sections A and B in the figure above): Select the proper based on the total capacity of the downstream indoor units, using the table below as a reference.

Unit : mm [inch]

Total capacity of indoor units	Liquid pipe	Gas pipe
P54 or below	ø9.52 [3/8"]	ø15.88 [5/8"]
P55 - P72	ø9.52 [3/8"]	ø19.05 [3/4"]
P73 - P96	ø9.52 [3/8"]	ø22.2 [7/8"]

Unit : mm [inch]

Operation		Pipe sections		
	Total capacity of the indoor units that are connected to the BC controller	High-pressure side (liquid)	Low-pressure side (gas)	Liquid pipe side
On the BC controller side	P72 model or below	ø15.88 [5/8"] (Braze connection)	ø19.05 [3/4"] (Braze connection)	ø9.52 [3/8"] (Braze connection)
	P73 - P108	ø19.05 [3/4"] (Braze connection)	ø22.2 [7/8"] (Braze connection)	
	P109 - P126		ø28.58 [1-1/8"] (Braze connection)	ø12.7 [1/2"] (Braze connection)
	P127 - P144	ø22.2 [7/8"] (Braze connection)		ø15.88 [5/8"] (Braze connection)
	P145 - P168			

Select the proper size pipes for the main unit based on the total capacity of the indoor units that are connected to both sub BC controllers. Select the proper size pipes for the sub controller side based on the total capacity of the indoor units that are connected to the sub controller.

III Heat source Unit Components

[1] Heat source Unit Components and Refrigerant Circuit.....	79
[2] Control Box of the Heat source Unit	87
[3] Heat source Unit Circuit Board	93
[4] BC Controller Components	105
[5] Control Box of the BC Controller.....	108
[6] BC Controller Circuit Board.....	109



[1] Heat source Unit Components and Refrigerant Circuit

1. Front view of a heat source unit

- (1) PQHY-P72, 96, 120TLMU-A1, PQRY-P72, 96, 120TLMU-A1
PQHY-P72, 96, 120YLMU-A1, PQRY-P72, 96, 120YLMU-A1

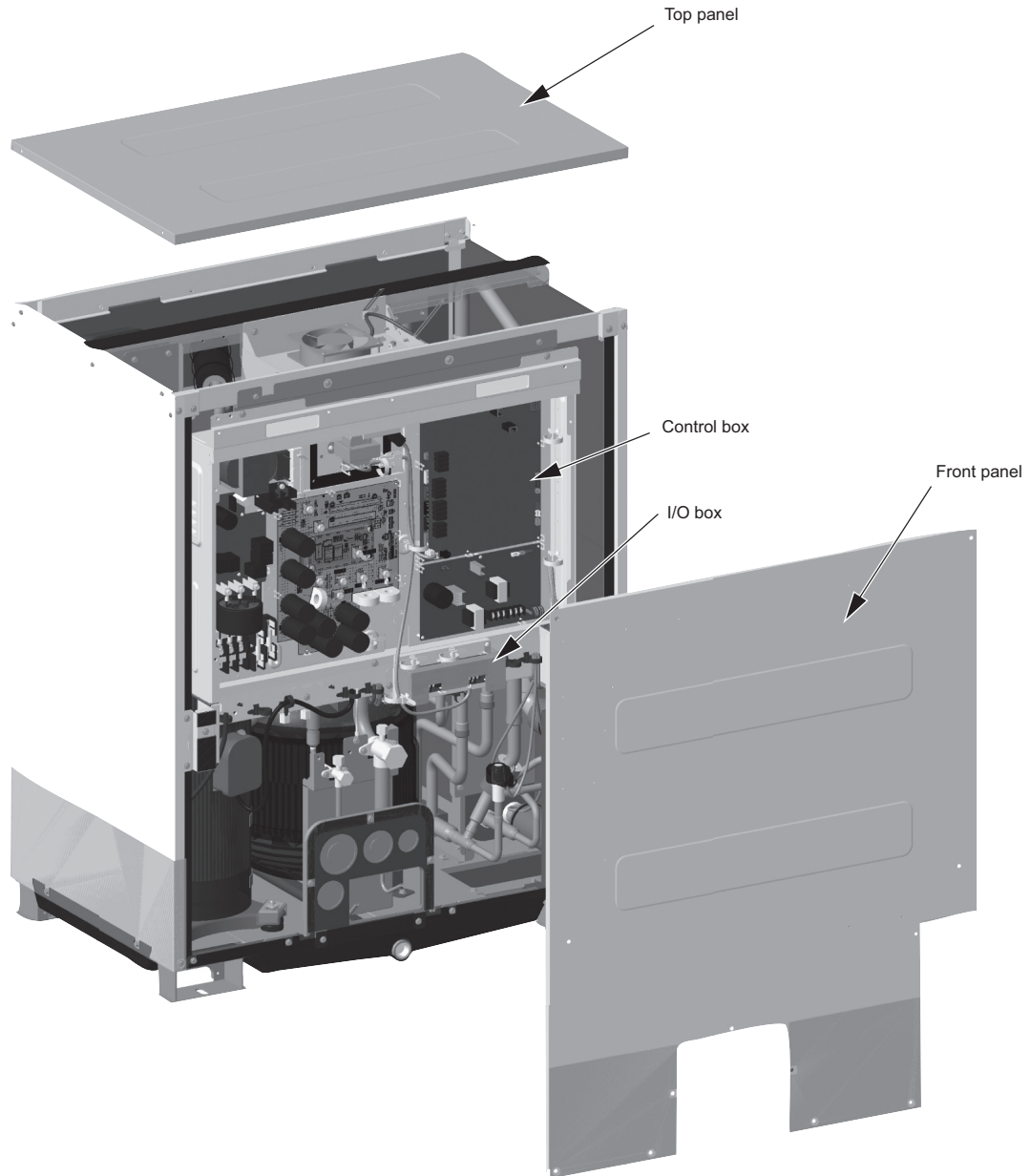

(2) PQHY-P144, 168, 192, 216, 240TLMU-A1, PQRV-P144, 168, 192, 216, 240TLMU-A1
PQHY-P144, 168, 192, 216, 240YLMU-A1, PQRV-P144, 168, 192, 216, 240YLMU-A1

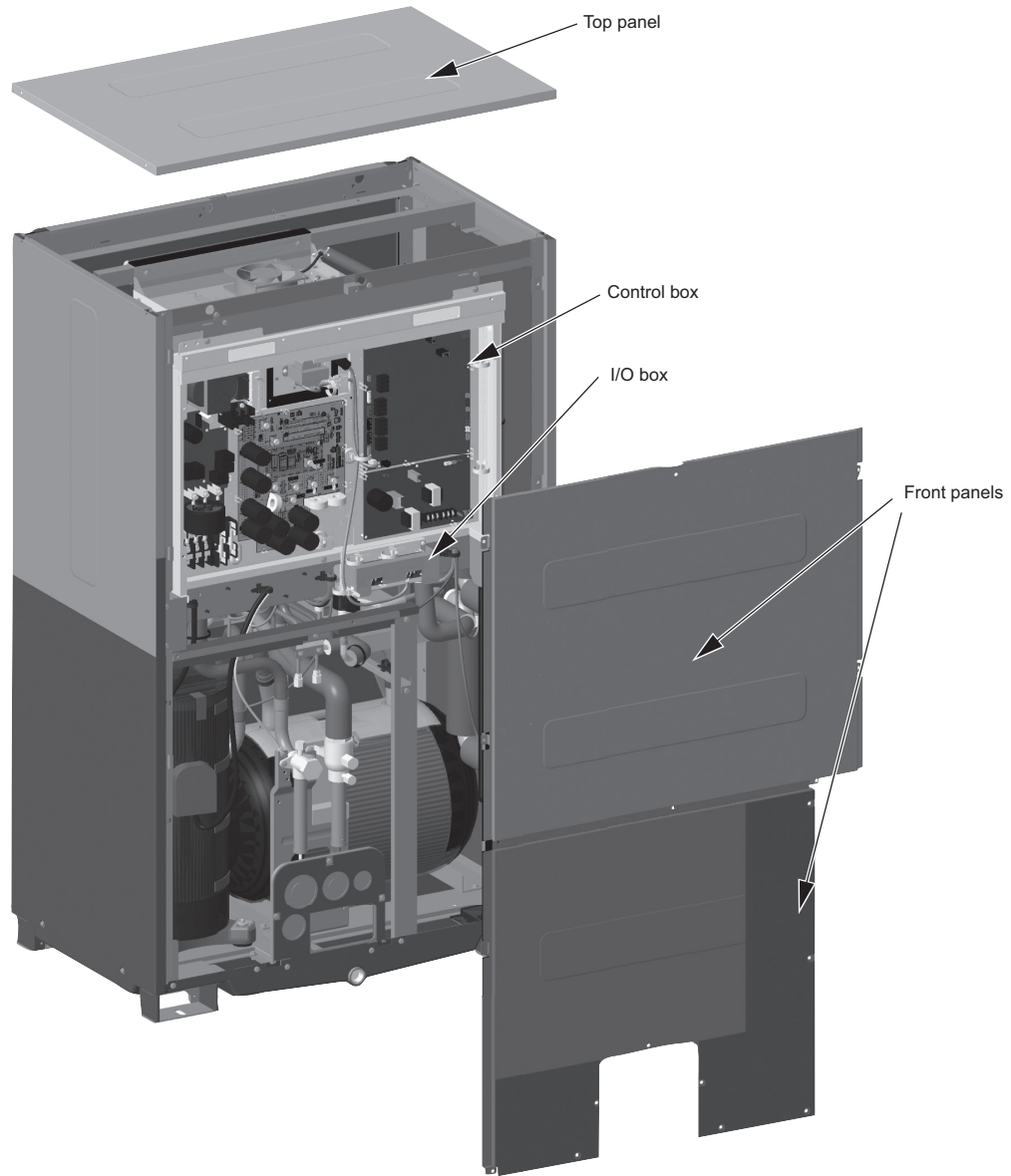

2. Refrigerant circuit

(1) PQHY-P72, 96, 120TLMU-A1, PQHY-P72, 96, 120YLMU-A1

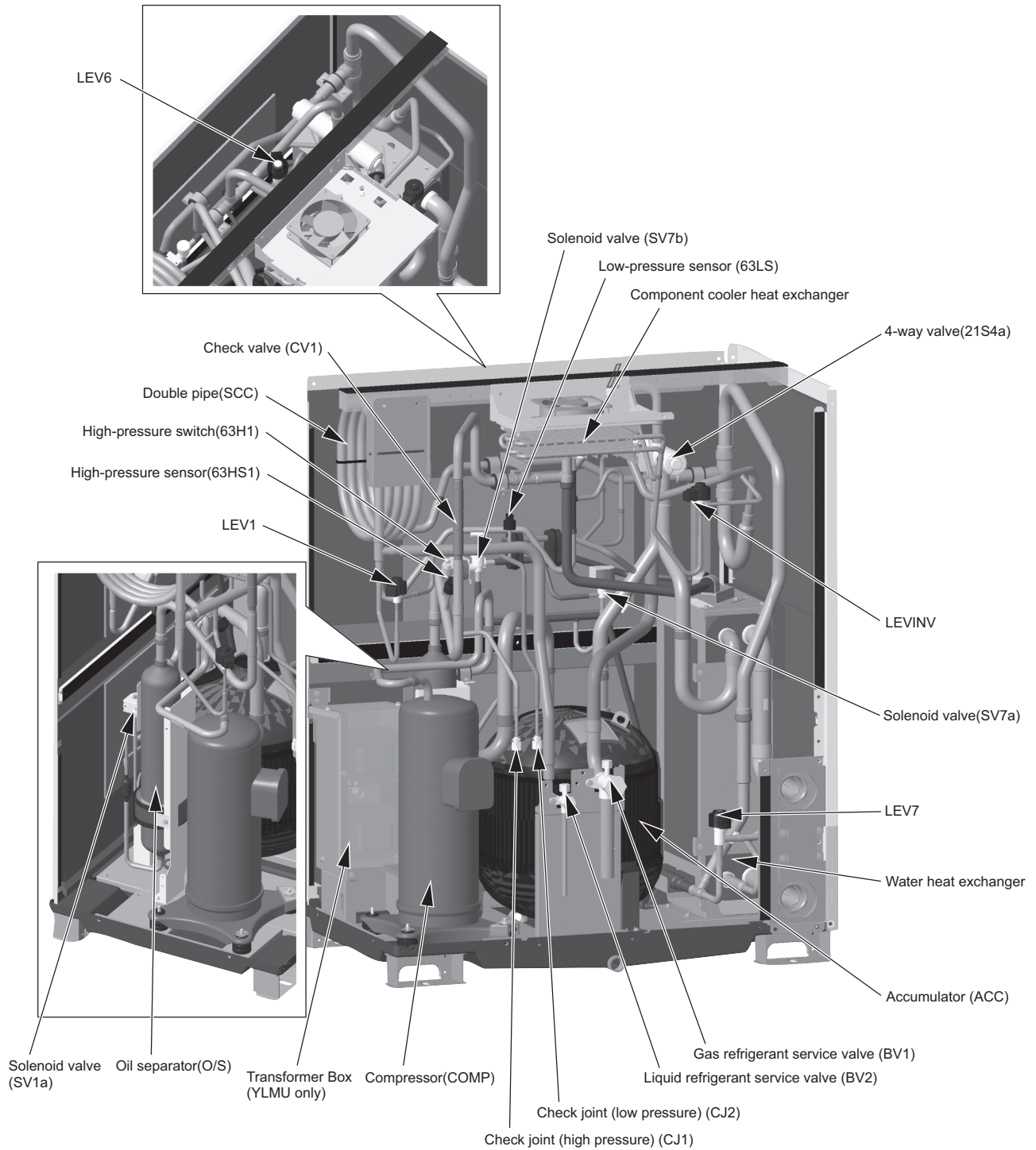

(2) PQRY-P72, 96, 120TLMU-A1, PQRY-P72, 96, 120YLMU-A1

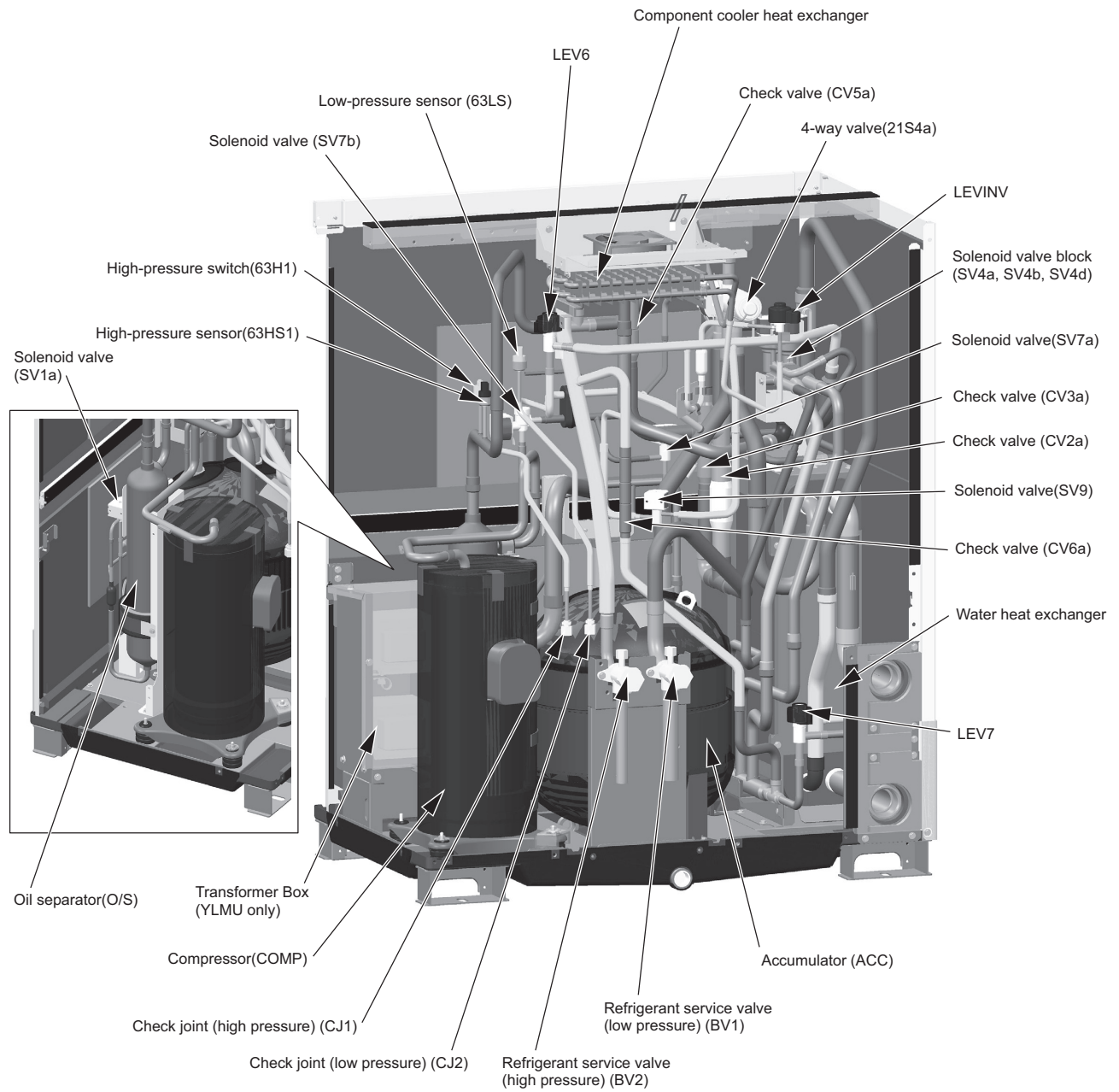

(3) PQHY-P144, 168, 192TLMU-A1, PQHY-P144, 168, 192YLMU-A1

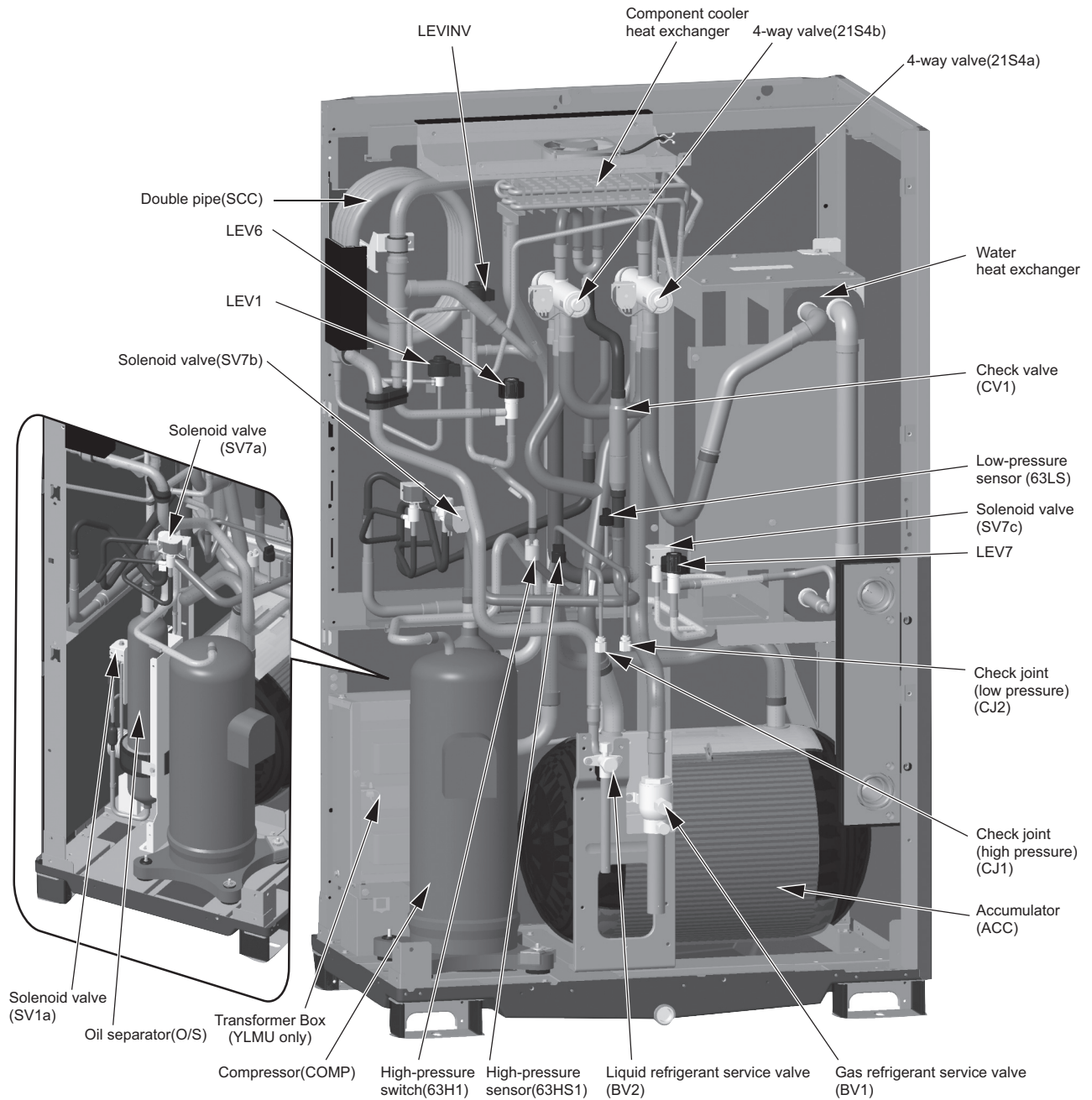

(4) PQRV-P144, 168, 192TLMU-A1, PQRV-P144, 168, 192YLMU-A1

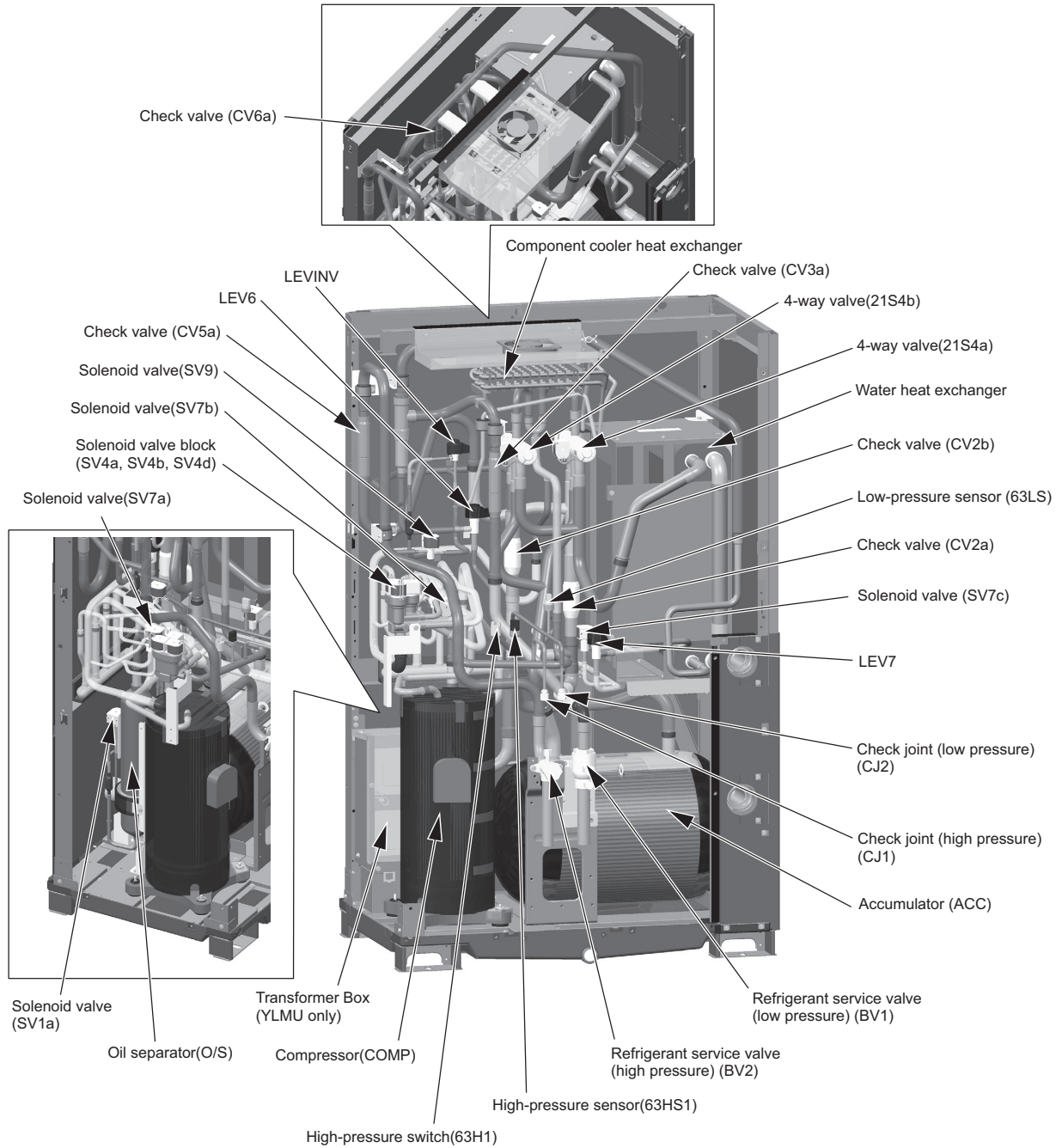

(5) PQHY-P216, 240TLMU-A1, PQHY-P216, 240YLMU-A1

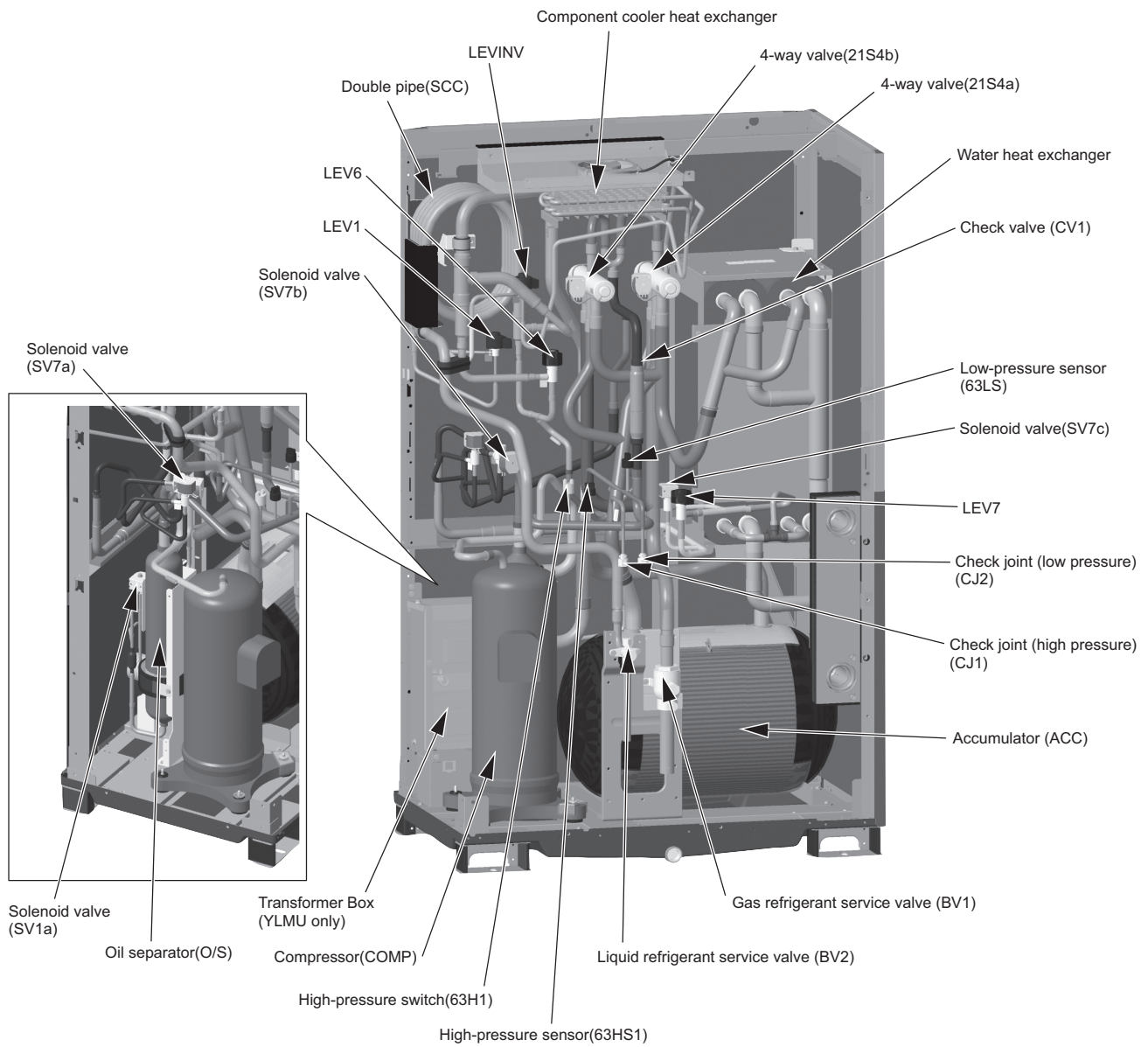

(6) PQRV-P216, 240TLMU-A1, PQRV-P216, 240YLMU-A1

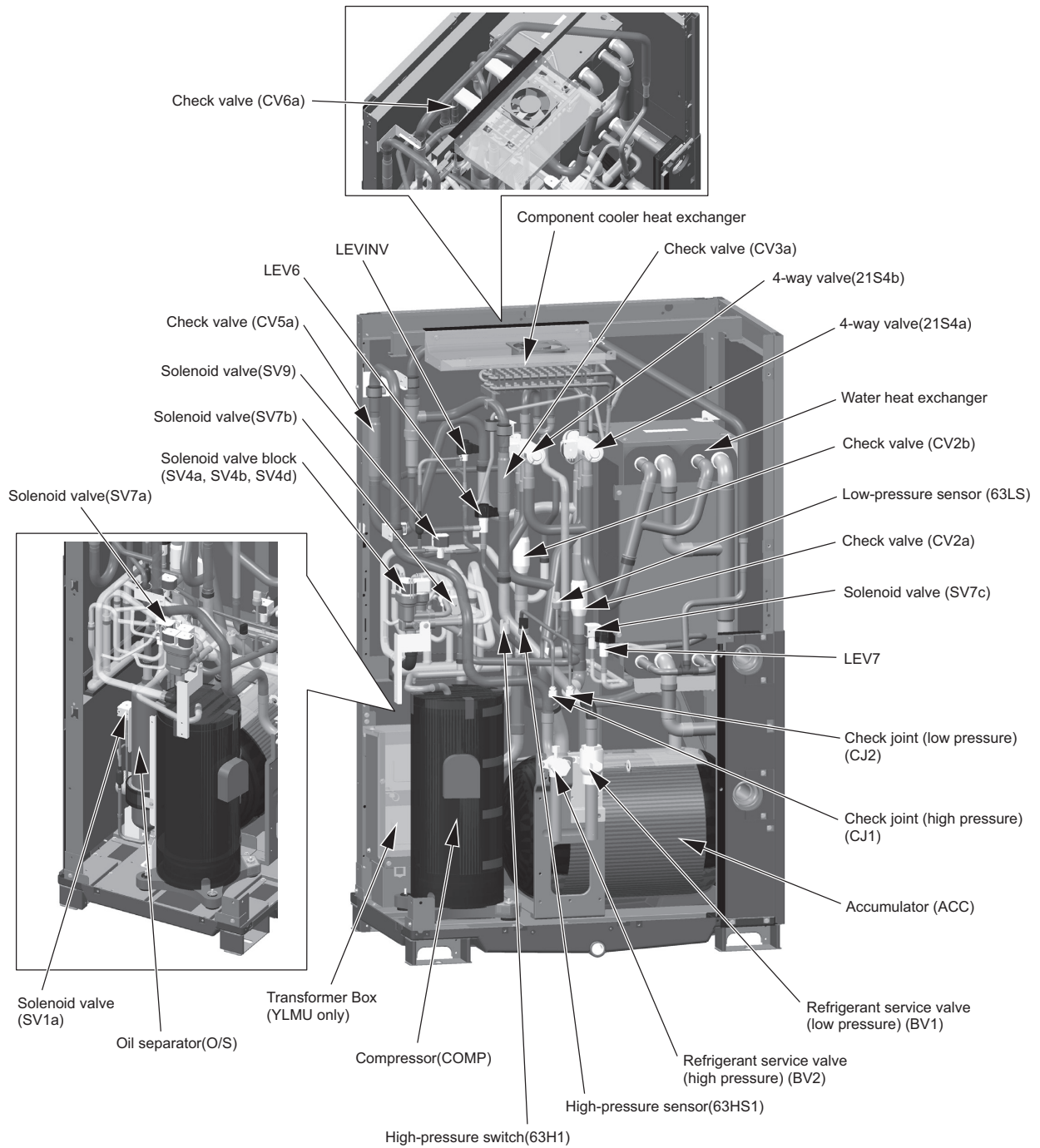

[2] Control Box of the Heat source Unit

1. Control Box

<HIGH VOLTAGE WARNING>

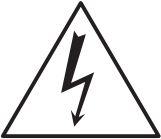

- Control box houses high-voltage parts.
- When opening or closing the front panel of the control box, do not let it come into contact with any of the internal components.
- Before inspecting the inside of the control box, turn off the power, keep the unit off for at least 10 minutes, and check that the the voltage of the electrolytic capacitor (Inverter main circuit) is 20VDC or below. (It takes about 10 minutes to discharge electricity after the power supply is turned off.)

(1) PQHY-P72, 96, 120TLMU-A1, PQRY-P72, 96, 120TLMU-A1

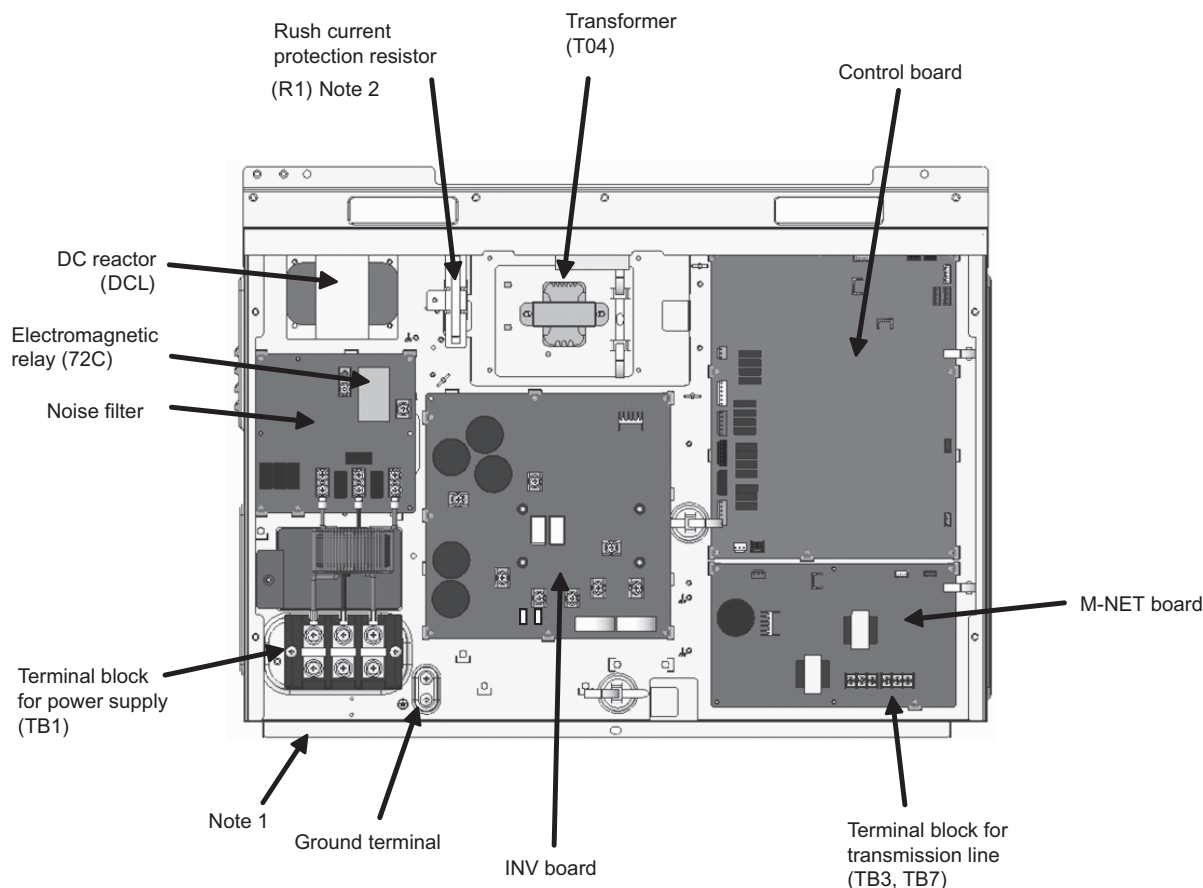

Note

- 1) Exercise caution not to damage the bottom and the front panel of the control box. Damage to these parts affect the waterproof and dust proof properties of the control box and may result in damage to its internal components.
- 2) Faston terminals have a locking function. Make sure the cable heads are securely locked in place. Press the tab on the terminals to remove them.
- 3) Control box houses high temperature parts. Be well careful even after turning off the power source.
- 4) When the power is turned on, the compressor is energized even while it is not operating. Before turning on the power, disconnect all power supply wires from the compressor terminal block, and measure the insulation resistance of the compressor. Check the compressor for a ground fault. If the insulation resistance is 1.0 MΩ or below, connect all power supply wires to the compressor and turn on the power to the outdoor unit. The liquid refrigerant in the compressor will evaporate by energizing the compressor.

(2) PQHY-P144, 168, 192TLMU-A1, PQRV-P144, 168, 192TLMU-A1

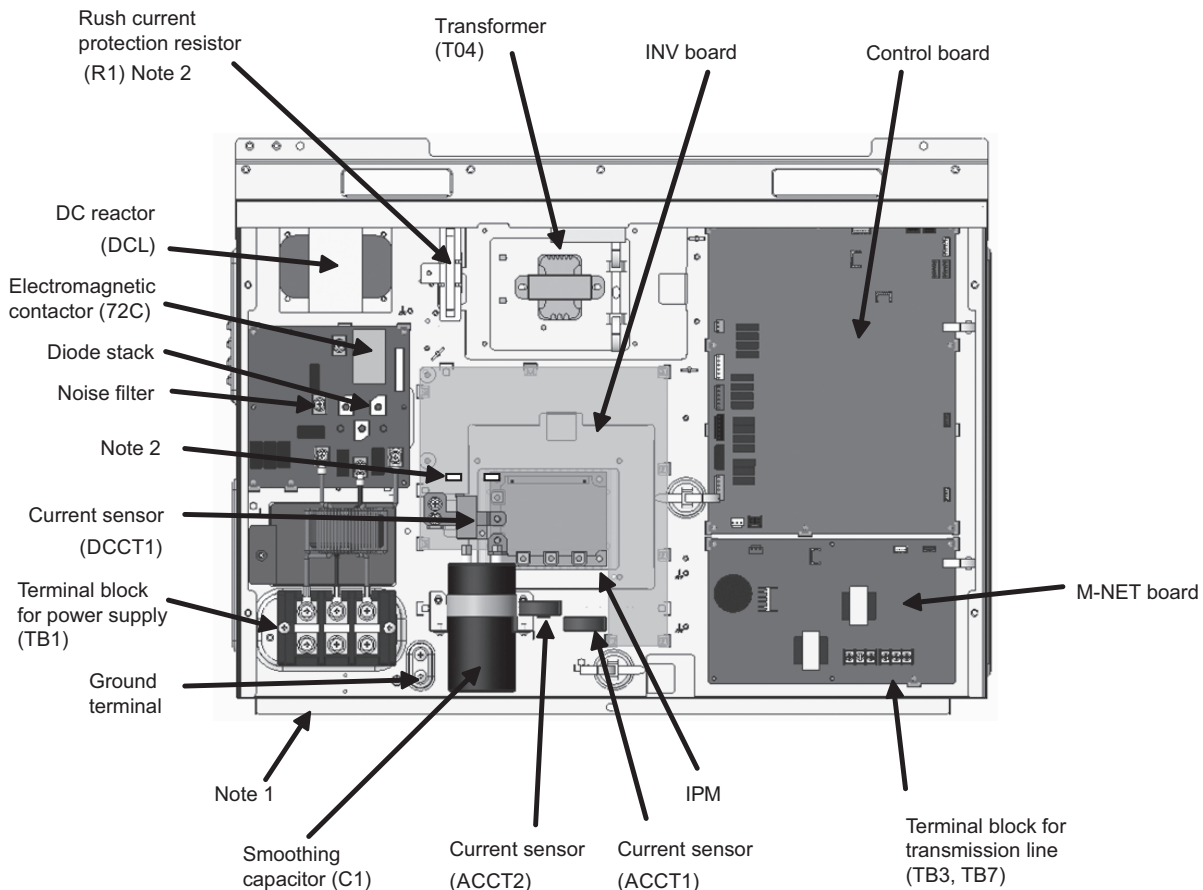

Note

- 1) Exercise caution not to damage the bottom and the front panel of the control box. Damage to these parts affect the waterproof and dust proof properties of the control box and may result in damage to its internal components.
- 2) Faston terminals have a locking function. Make sure the cable heads are securely locked in place. Press the tab on the terminals to remove them.
- 3) Control box houses high temperature parts. Be well careful even after turning off the power source.
- 4) When the power is turned on, the compressor is energized even while it is not operating. Before turning on the power, disconnect all power supply wires from the compressor terminal block, and measure the insulation resistance of the compressor. Check the compressor for a ground fault. If the insulation resistance is 1.0 MΩ or below, connect all power supply wires to the compressor and turn on the power to the outdoor unit. The liquid refrigerant in the compressor will evaporate by energizing the compressor.

(3) PQHY-P216, 240TLMU-A1, PQRY-P216, 240TLMU-A1

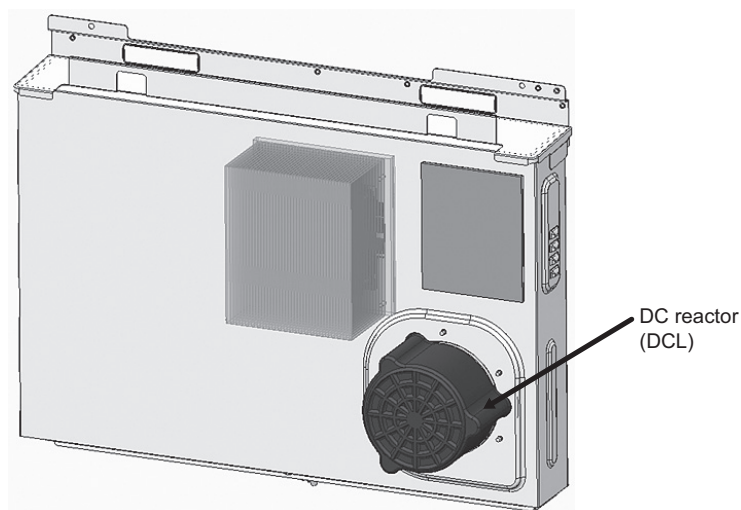
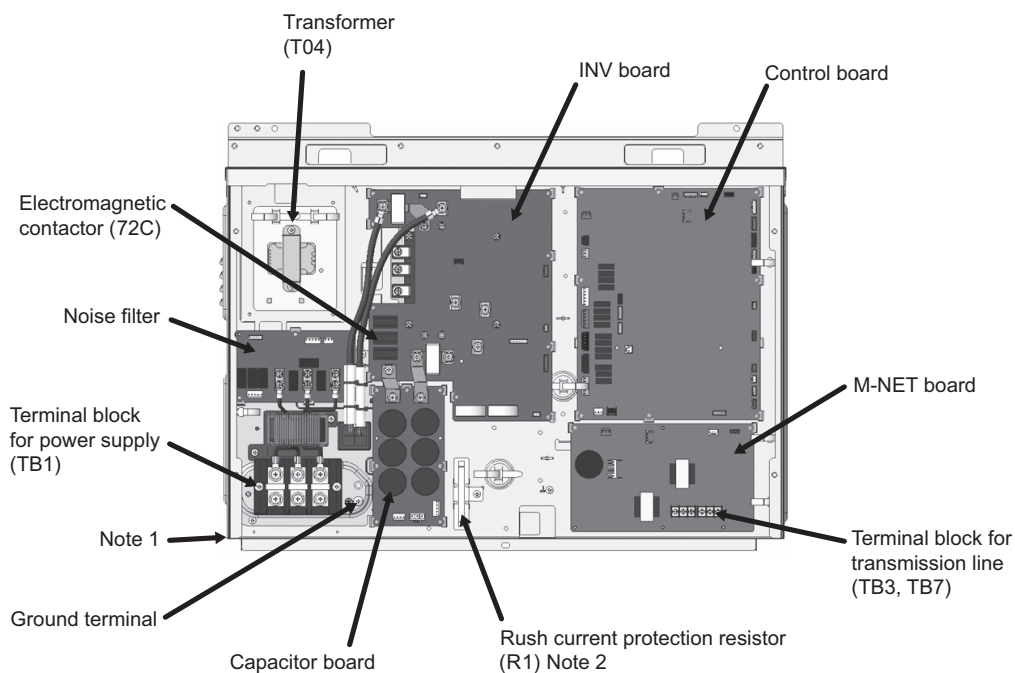

Note

- 1) Exercise caution not to damage the bottom and the front panel of the control box. Damage to these parts affect the waterproof and dust proof properties of the control box and may result in damage to its internal components.
- 2) Faston terminals have a locking function. Make sure the cable heads are securely locked in place. Press the tab on the terminals to remove them.
- 3) Control box houses high temperature parts. Be well careful even after turning off the power source.
- 4) When the power is turned on, the compressor is energized even while it is not operating. Before turning on the power, disconnect all power supply wires from the compressor terminal block, and measure the insulation resistance of the compressor. Check the compressor for a ground fault. If the insulation resistance is 1.0 MΩ or below, connect all power supply wires to the compressor and turn on the power to the outdoor unit. The liquid refrigerant in the compressor will evaporate by energizing the compressor.

(4) PQHY-P72, 96, 120, 144, 168, 192, 216, 240YLMU-A1,
PQRY-P72, 96, 120, 144, 168, 192, 216, 240YLMU-A1

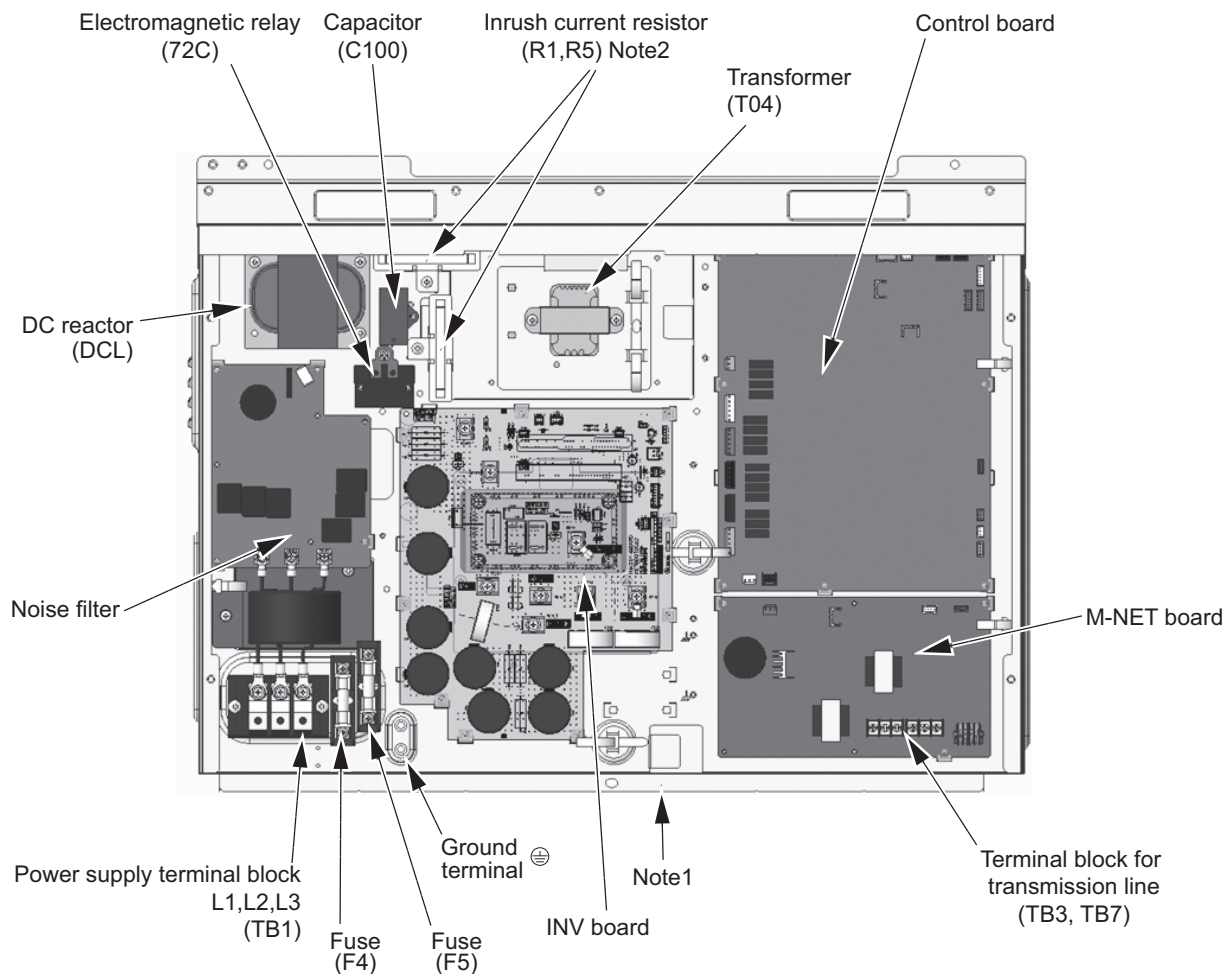

Note

- 1) Exercise caution not to damage the bottom and the front panel of the control box. Damage to these parts affect the waterproof and dust proof properties of the control box and may result in damage to its internal components.
- 2) Faston terminals have a locking function. Make sure the cable heads are securely locked in place. Press the tab on the terminals to remove them.
- 3) Control box houses high temperature parts. Be well careful even after turning off the power source.
- 4) When the power is turned on, the compressor is energized even while it is not operating. Before turning on the power, disconnect all power supply wires from the compressor terminal block, and measure the insulation resistance of the compressor. Check the compressor for a ground fault. If the insulation resistance is 1.0 MΩ or below, connect all power supply wires to the compressor and turn on the power to the outdoor unit. The liquid refrigerant in the compressor will evaporate by energizing the compressor.

2. I/O Box

PQHY-P72, 96, 120, 144, 168, 192, 216, 240TLMU-A1

PQRY-P72, 96, 120, 144, 168, 192, 216, 240TLMU-A1

PQHY-P72, 96, 120, 144, 168, 192, 216, 240YLMU-A1

PQRY-P72, 96, 120, 144, 168, 192, 216, 240YLMU-A1

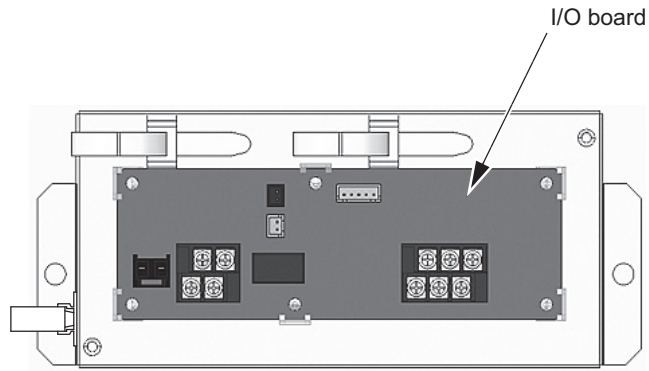

3. Transformer Box

(1) PQHY-P72, 96, 120, 144, 168, 192, 216, 240YLMU-A1, PQRY-P72, 96, 120, 144, 168, 192, 216, 240YLMU-A1

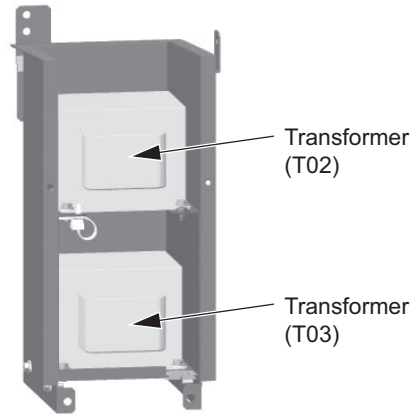

[3] Heat source Unit Circuit Board

1. Heat source unit control board

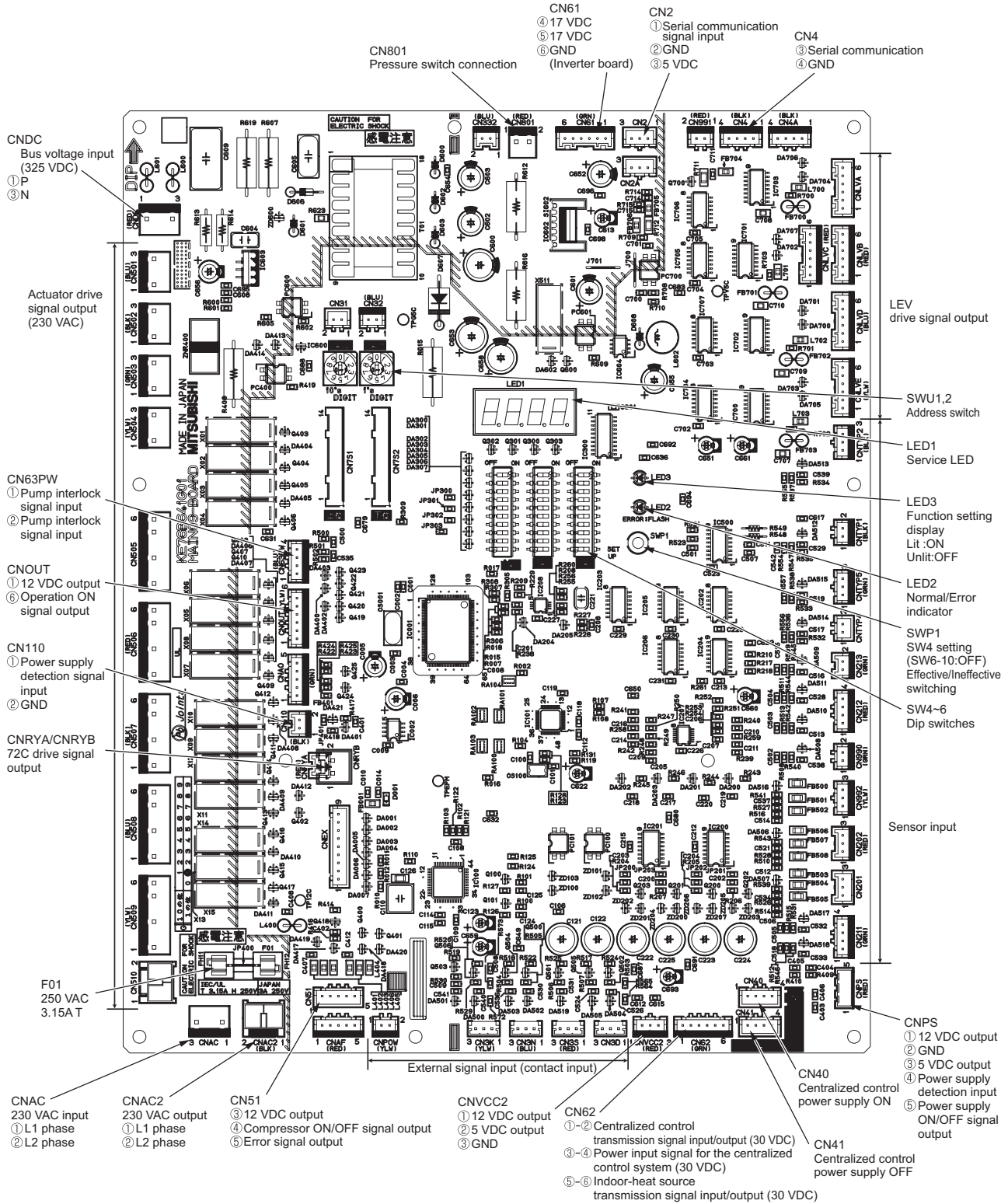

For information about the display of SW4 function settings, refer to section VII [1] Functions and Factory Settings of the Dip-switches (page 159).

2. M-NET board

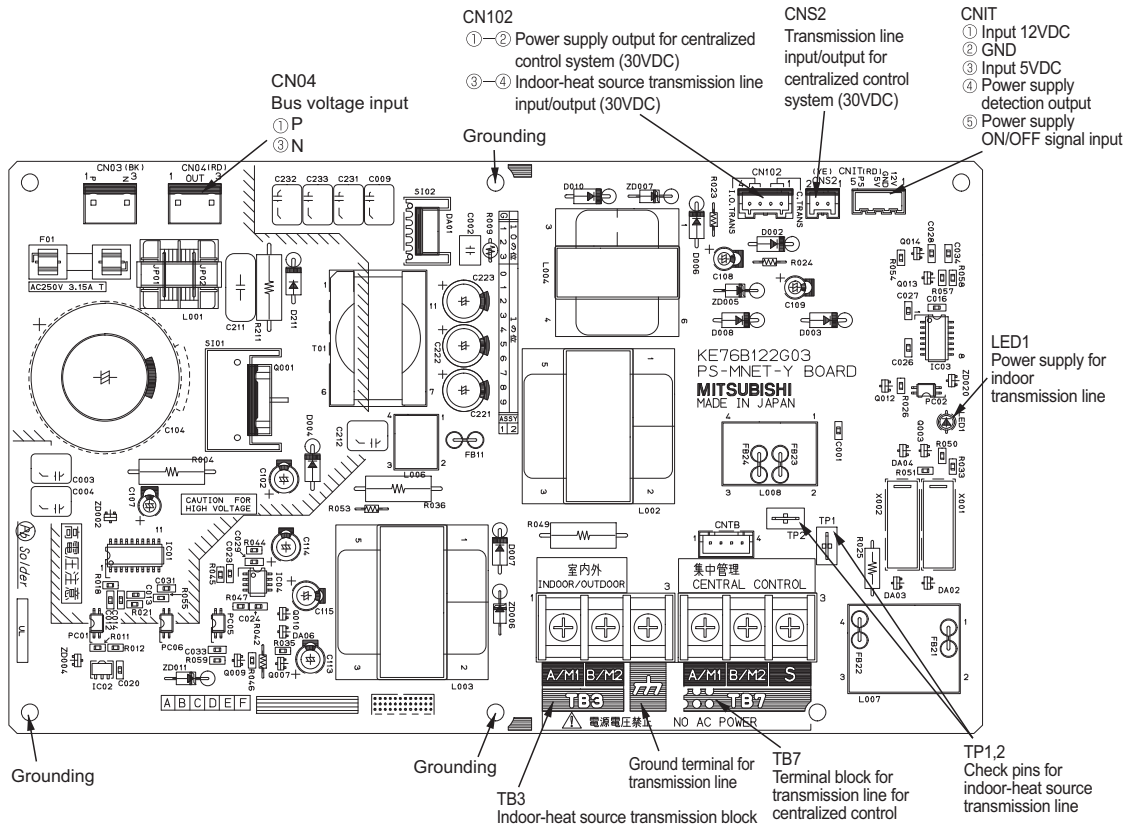

3. INV board

(1) PQHY-P72, 96, 120TLMU-A1, PQRY-P72, 96, 120TLMU-A1

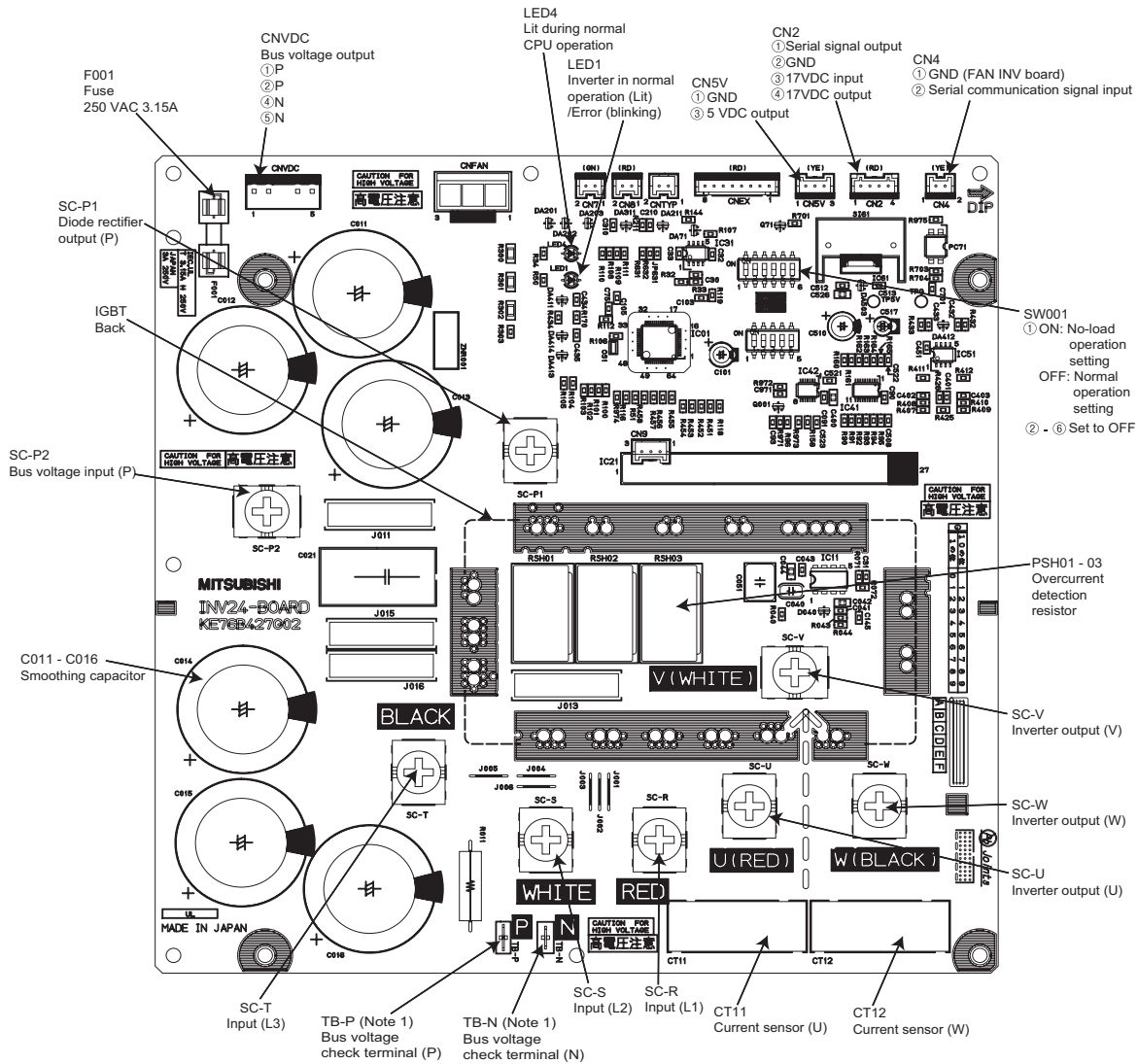

Note

- 1) When opening or closing the front panel of the control box, do not let it come into contact with any of the internal components. Before inspecting the inside of the control box, turn off the power, keep the unit off for at least 10 minutes, and confirm that the electrolytic capacitor voltage (inverter main circuit) has dropped to 20 VDC or less. It takes about 10 minutes to discharge electricity after the power supply is turned off.
- 2) Control box houses high temperature parts. Be well careful even after turning off the power source.
- 3) When the power is turned on, the compressor is energized even while it is not operating. Before turning on the power, disconnect all power supply wires from the compressor terminal block, and measure the insulation resistance of the compressor. Check the compressor for a ground fault. If the insulation resistance is 1.0 MΩ or below, connect all power supply wires to the compressor and turn on the power to the outdoor unit. The liquid refrigerant in the compressor will evaporate by energizing the compressor.

(2) PQHY-P144, 168, 192TLMU-A1, PQRY-P144, 168, 192TLMU-A1

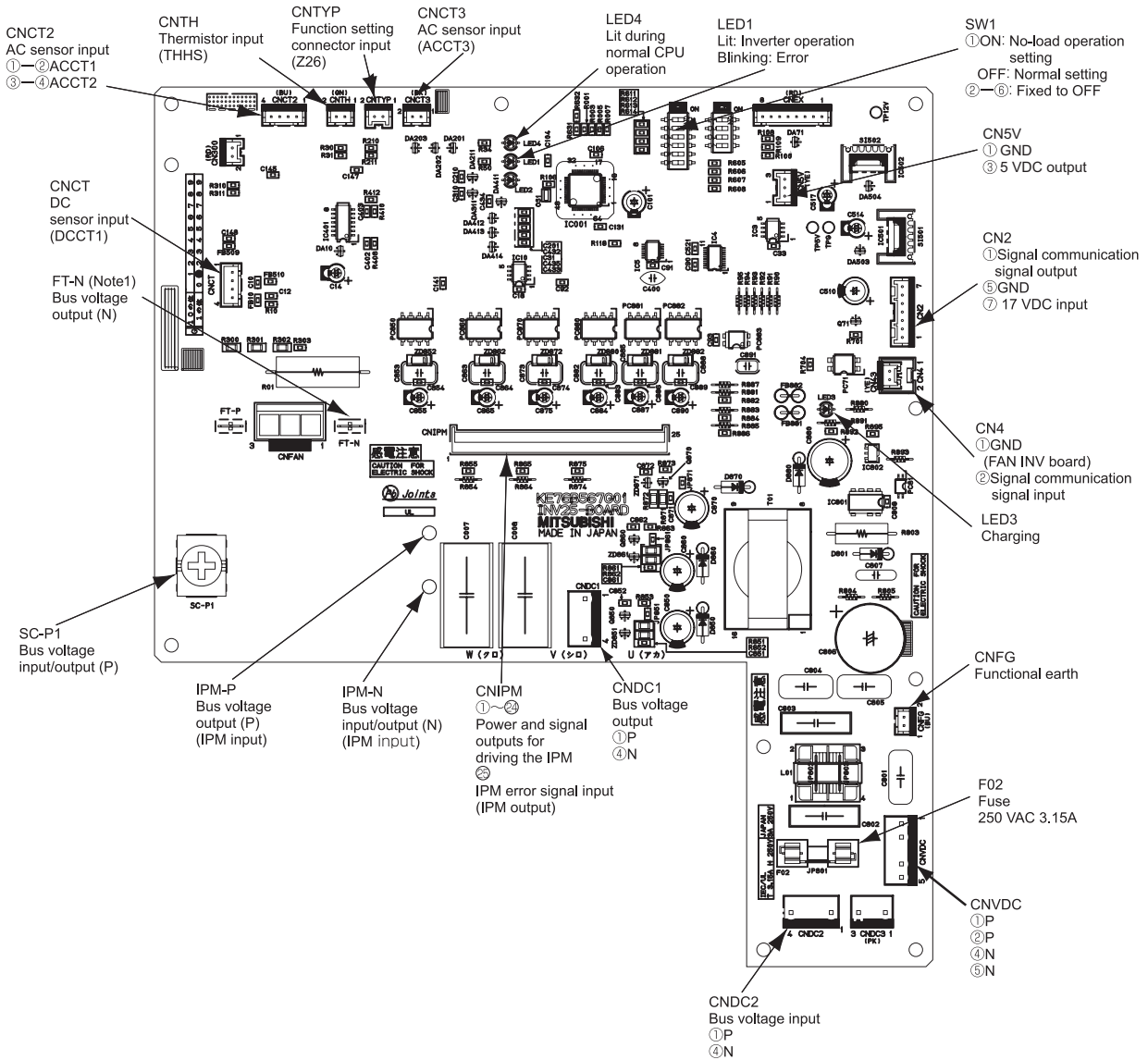

Note

- 1) Faston terminals have a locking function. Make sure the cable heads are securely locked in place. Press the tab on the terminals to remove them.
- 2) When opening or closing the front panel of the control box, do not let it come into contact with any of the internal components. Before inspecting the inside of the control box, turn off the power, keep the unit off for at least 10 minutes, and confirm that the capacitor voltage (inverter main circuit) has dropped to 20 VDC or less. It takes about 10 minutes to discharge electricity after the power supply is turned off.
- 3) Control box houses high temperature parts. Be well careful even after turning off the power source.
- 4) When the power is turned on, the compressor is energized even while it is operating. Before turning on the power, disconnect all power supply wires from the compressor AC terminal block, and measure the insulation resistance of the compressor. Check the compressor for a ground fault. If the insulation resistance is 1.0 MΩ or below, connect all power supply wires to the compressor and turn on the power to the outdoor unit. The liquid refrigerant in the compressor will evaporate by energizing the compressor.

(3) PQHY-P216, 240TLMU-A1, PQRV-P216, 240TLMU-A1

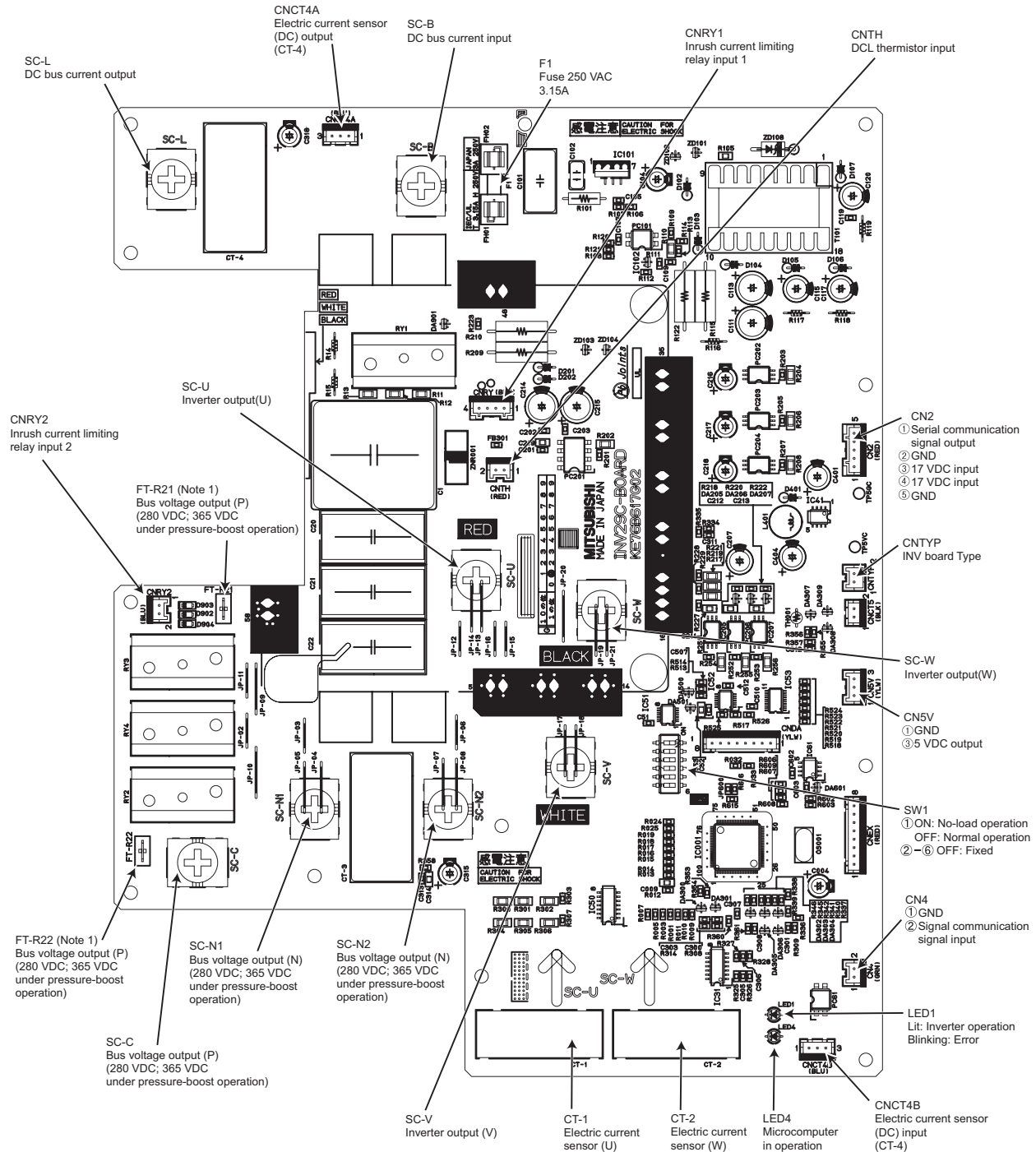

Note

- 1) Faston terminals have a locking function. Make sure the cable heads are securely locked in place. Press the tab on the terminals to remove them.
- 2) When opening or closing the front panel of the control box, do not let it come into contact with any of the internal components. Before inspecting the inside of the control box, turn off the power, keep the unit off for at least 10 minutes, and confirm that the capacitor voltage (inverter main circuit) has dropped to 20 VDC or less. It takes about 10 minutes to discharge electricity after the power supply is turned off.
- 3) Control box houses high temperature parts. Be well careful even after turning off the power source.
- 4) When the power is turned on, the compressor is energized even while it is not operating. Before turning on the power, disconnect all power supply wires from the compressor terminal block, and measure the insulation resistance of the compressor. Check the compressor for a ground fault. If the insulation resistance is 1.0 MΩ or below, connect all power supply wires to the compressor and turn on the power to the outdoor unit. The liquid refrigerant in the compressor will evaporate by energizing the compressor.

(4) PQHY-P72, 96, 120, 144, 168, 192, 216, 240YLMU-A1, PQRV-P72, 96, 120, 144, 168, 192, 216, 240YLMU-A1

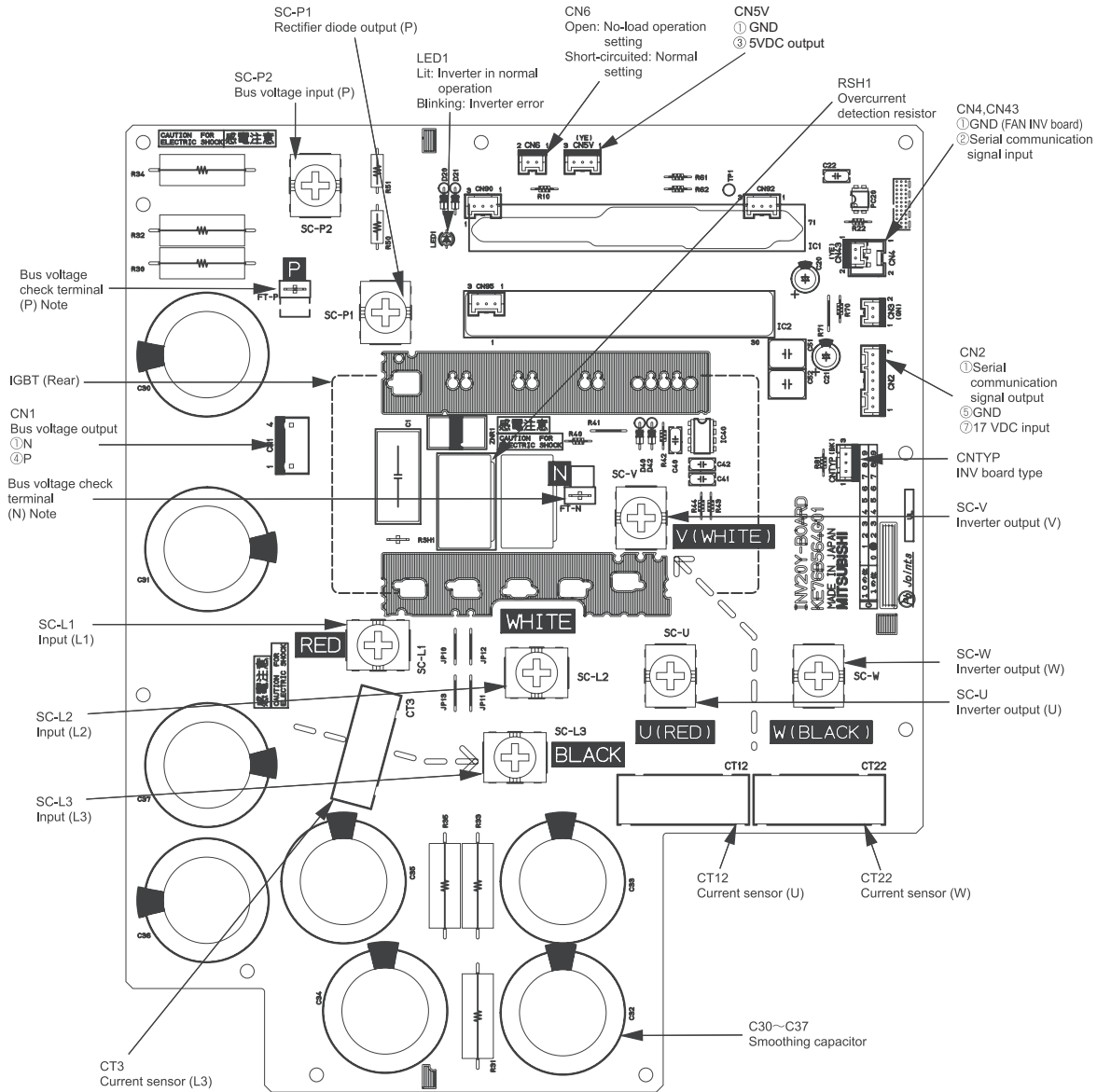

Note

- 1) When opening or closing the front panel of the control box, do not let it come into contact with any of the internal components. Before inspecting the inside of the control box, turn off the power, keep the unit off for at least 10 minutes, and confirm that the capacitor voltage (inverter main circuit) has dropped to 20 VDC or less. It takes about 10 minutes to discharge electricity after the power supply is turned off.
- 2) Control box houses high temperature parts. Be well careful even after turning off the power source.
- 3) When the power is turned on, the compressor is energized even while it is not operating. Before turning on the power, disconnect all power supply wires from the compressor terminal block, and measure the insulation resistance of the compressor. Check the compressor for a ground fault. If the insulation resistance is 1.0 MΩ or below, connect all power supply wires to the compressor and turn on the power to the outdoor unit. The liquid refrigerant in the compressor will evaporate by energizing the compressor.

4. CAP board

(1) PQHY-P216, 240TLMU-A1, PQRV-P216, 240TLMU-A1

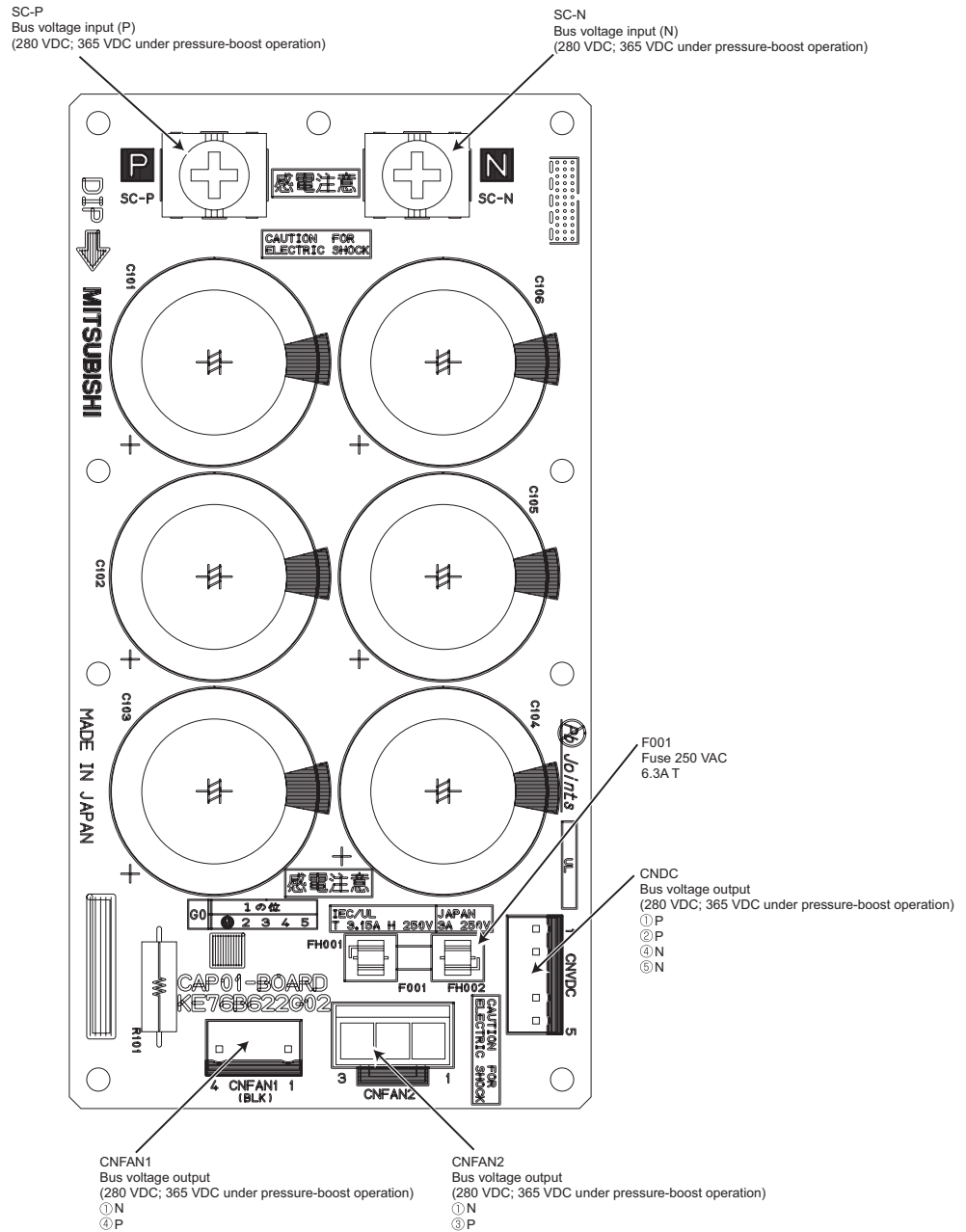

Note

- 1) When opening or closing the front panel of the control box, do not let it come into contact with any of the internal components. Before inspecting the inside of the control box, turn off the power, keep the unit off for at least 10 minutes, and confirm that the capacitor voltage (inverter main circuit) has dropped to 20 VDC or less. It takes about 10 minutes to discharge electricity after the power supply is turned off.
- 2) Control box houses high temperature parts. Be well careful even after turning off the power source.

5. I/O board

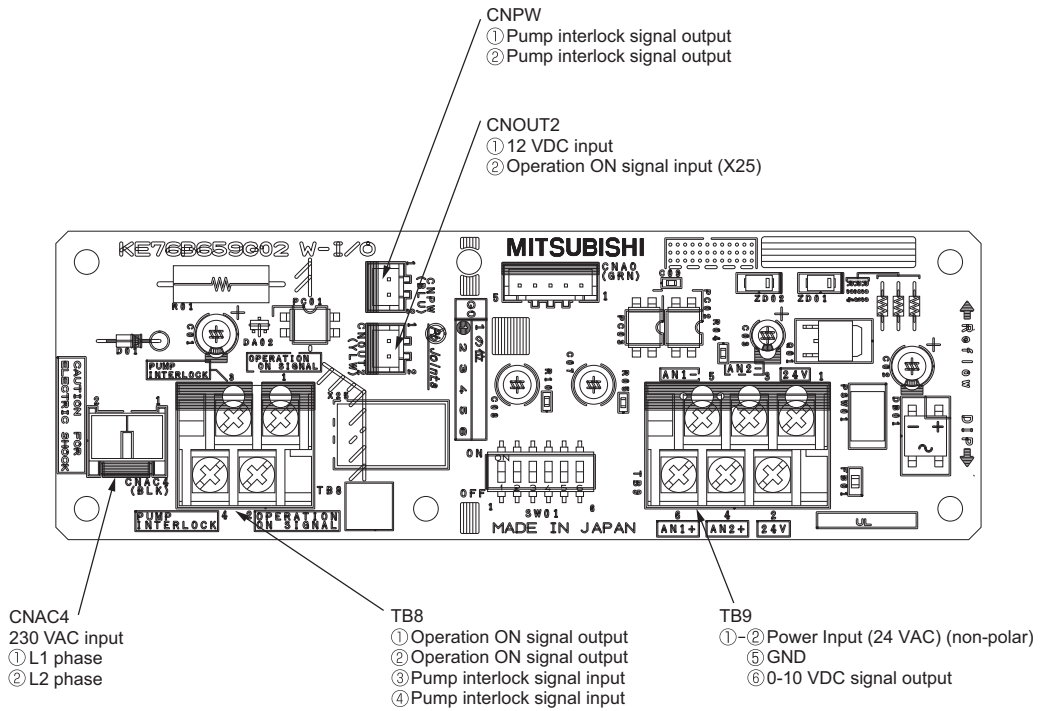

6. Noise Filter

(1) PQHY-P72, 96, 120TLMU-A1, PQRV-P72, 96, 120TLMU-A1

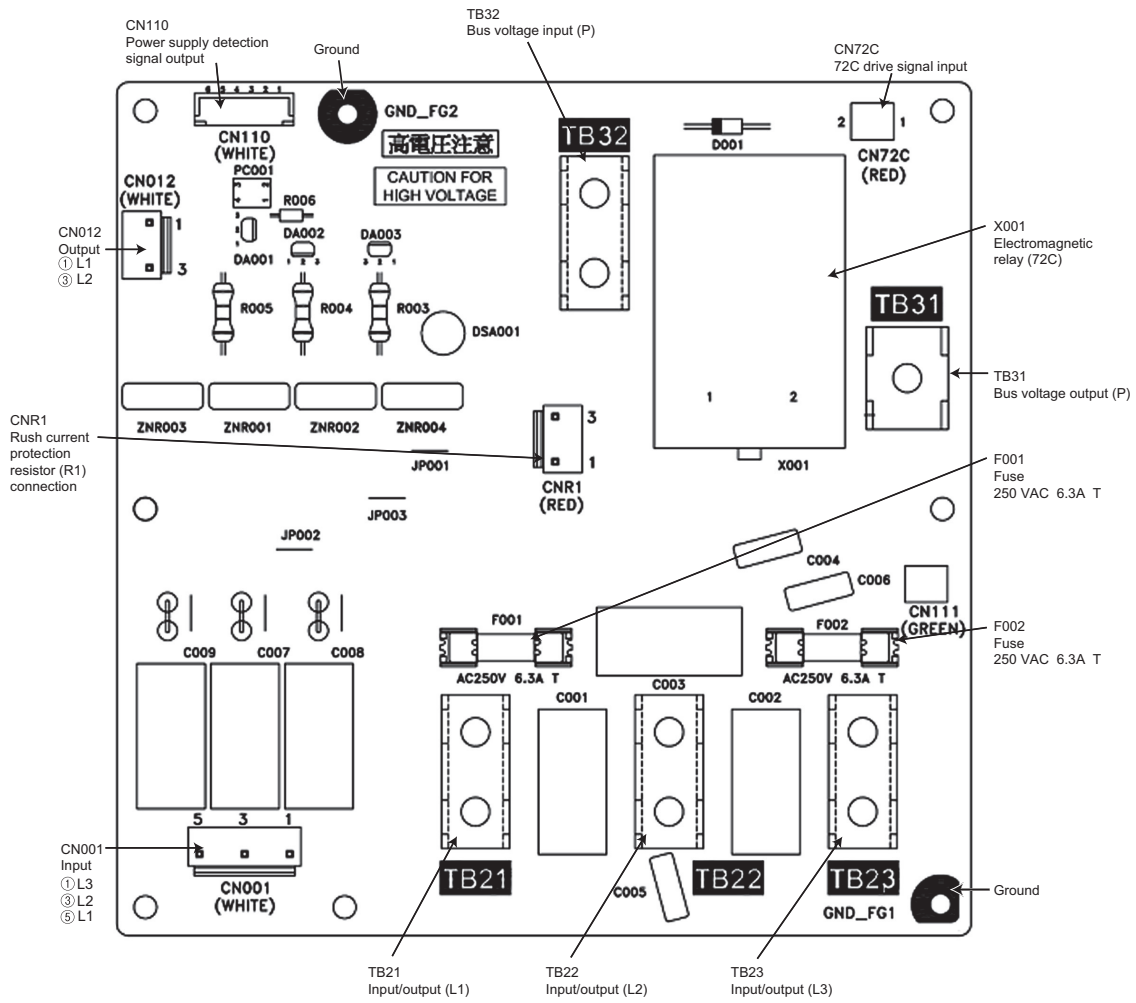

(2) PQHY-P144, 168, 192TLMU-A1, PQRY-P144, 168, 192TLMU-A1

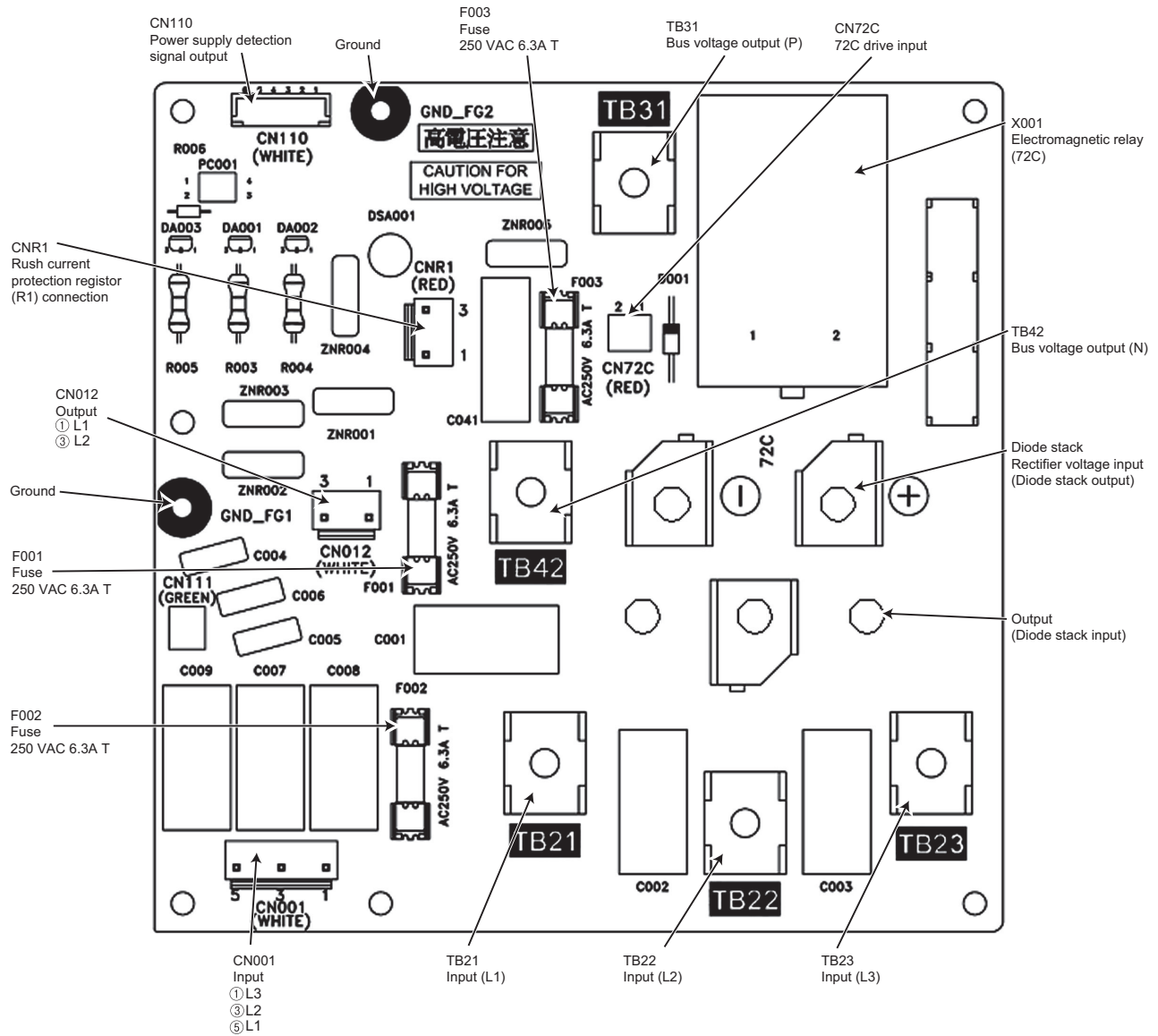

(3) PQHY-P216, 240TLMU-A1, PQRY-P216, 240TLMU-A1

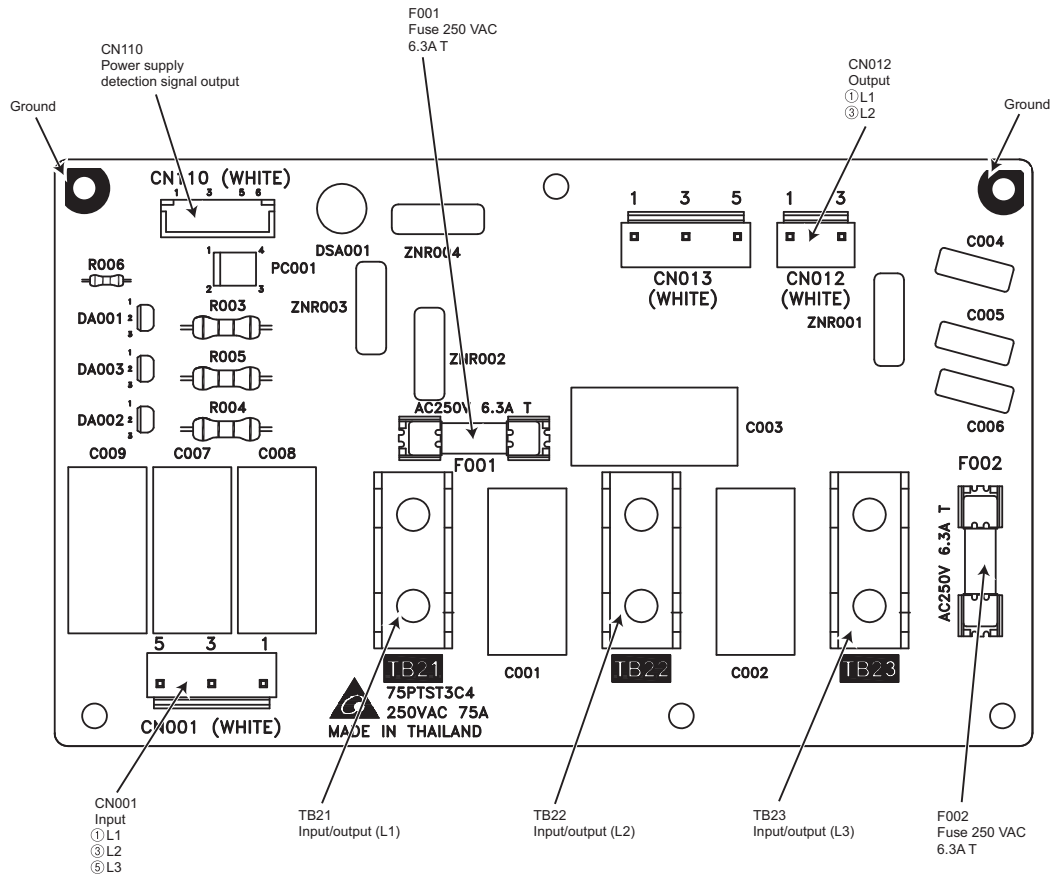

(4) PQHY-P72, 96, 120, 144, 168, 192, 216, 240YLMU-A1, PQRY-P72, 96, 120, 144, 168, 192, 216, 240YLMU-A1

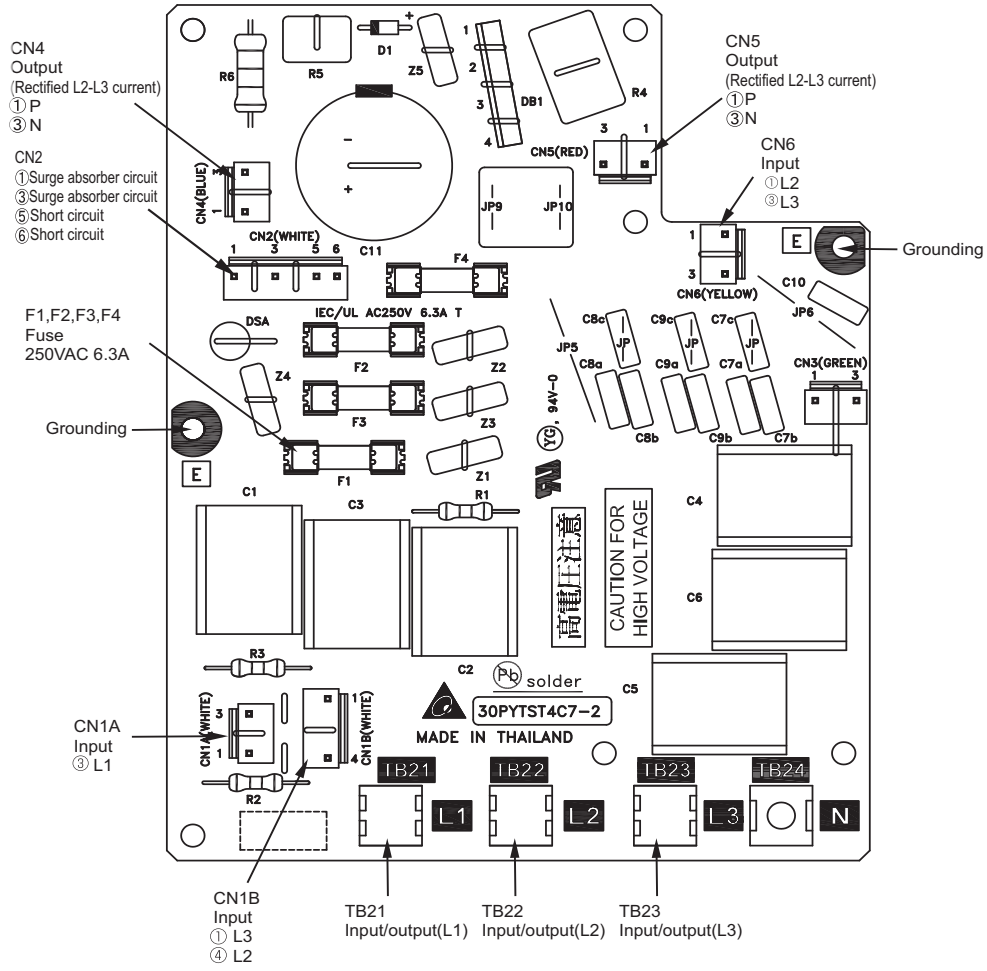

[4] BC Controller Components

1. CMB-P○○ NU-G1, GA1, HA1

(1) Front

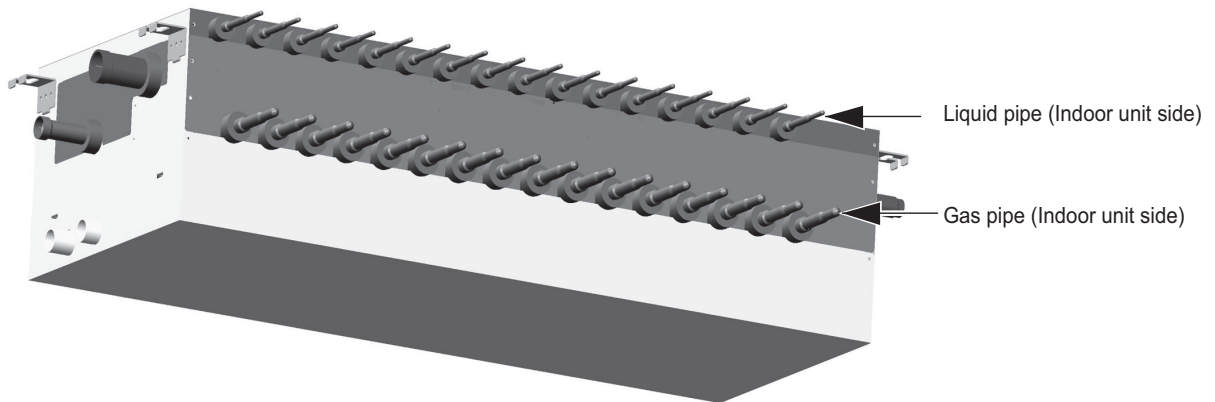

(2) Rear view <G1 type>

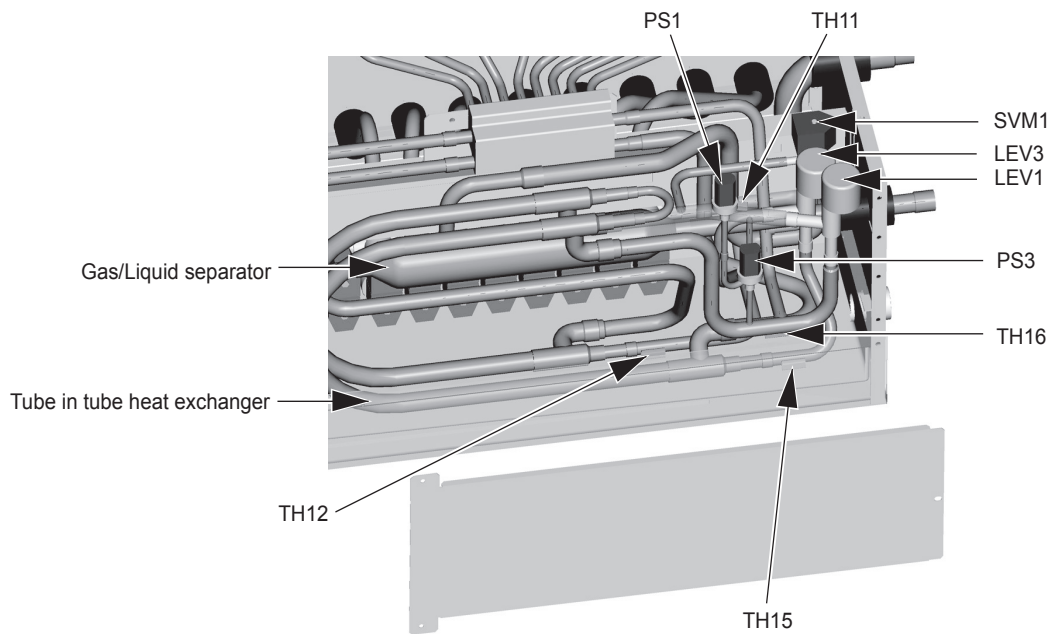

(3) Rear view <GA1 type>

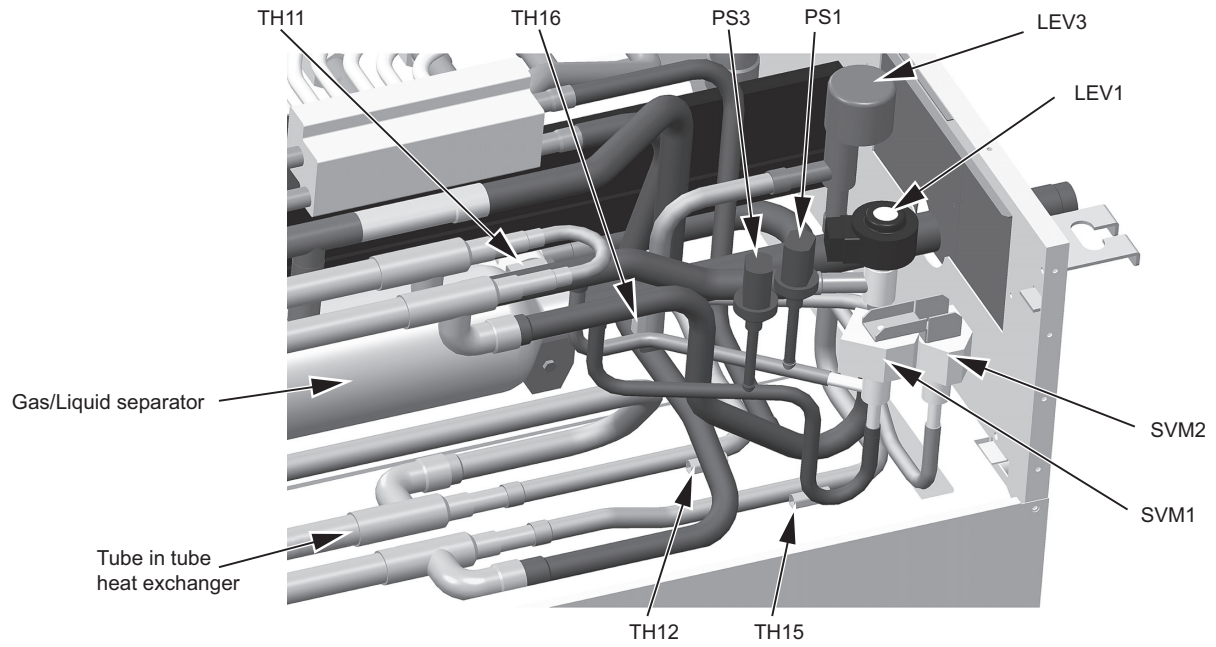

(4) Rear view <HA1 type>

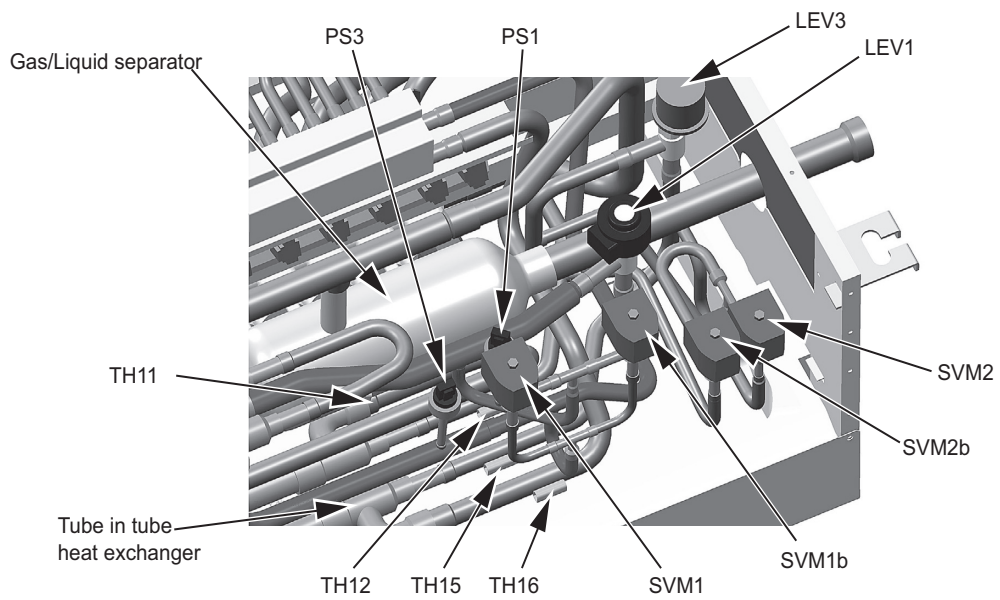

2. CMB-P〇〇 NU-GB1, HB1

(1) Front

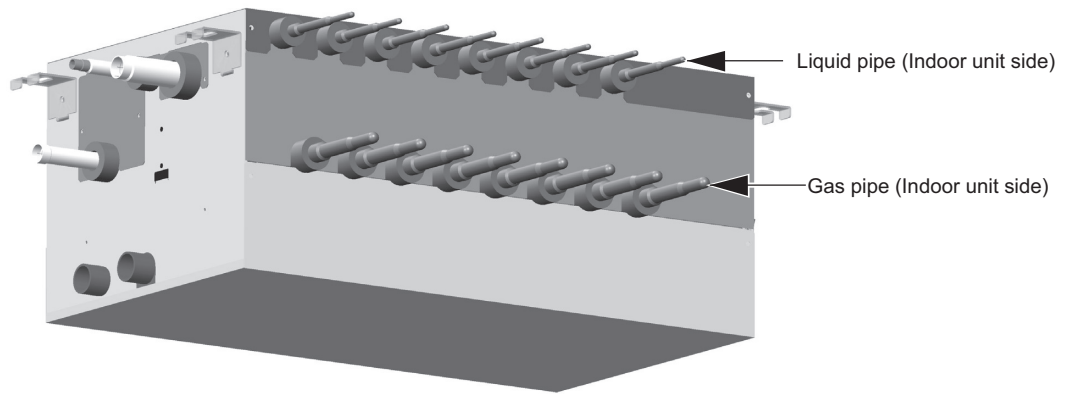

(2) Rear view

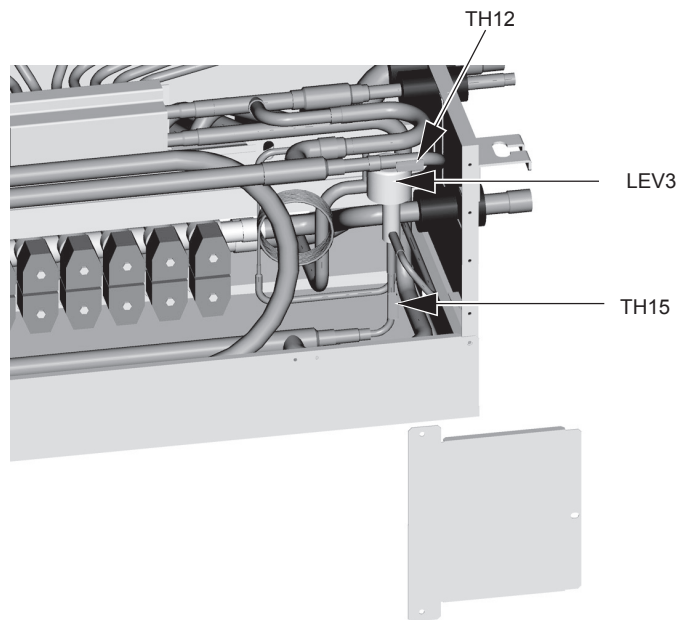

[5] Control Box of the BC Controller

1. CMB-P1016NU-G1, GA1, HA1

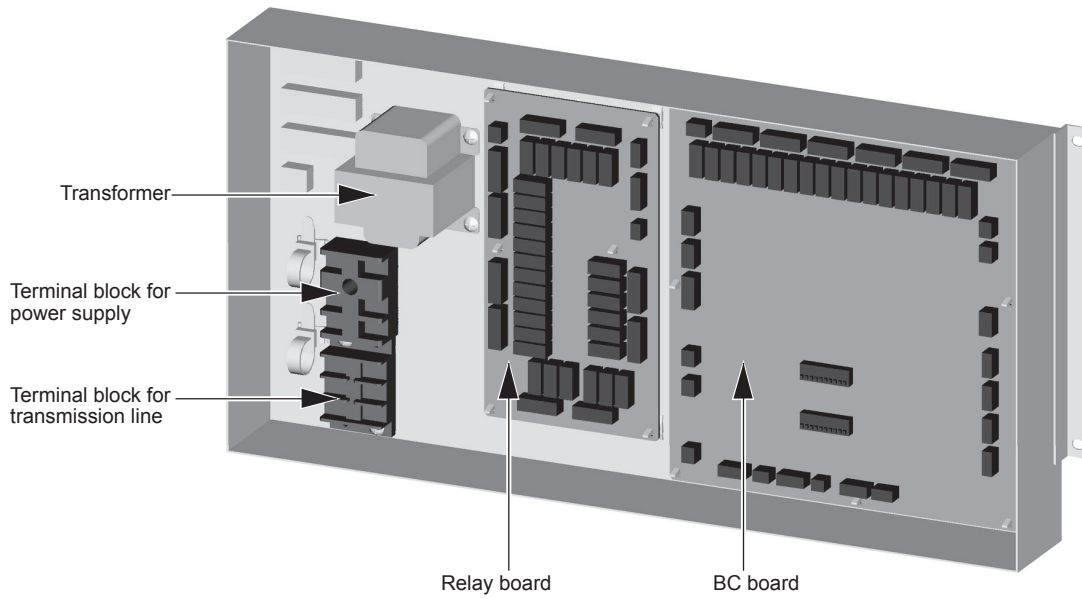

[6] BC Controller Circuit Board

1. BC controller circuit board (BC board)

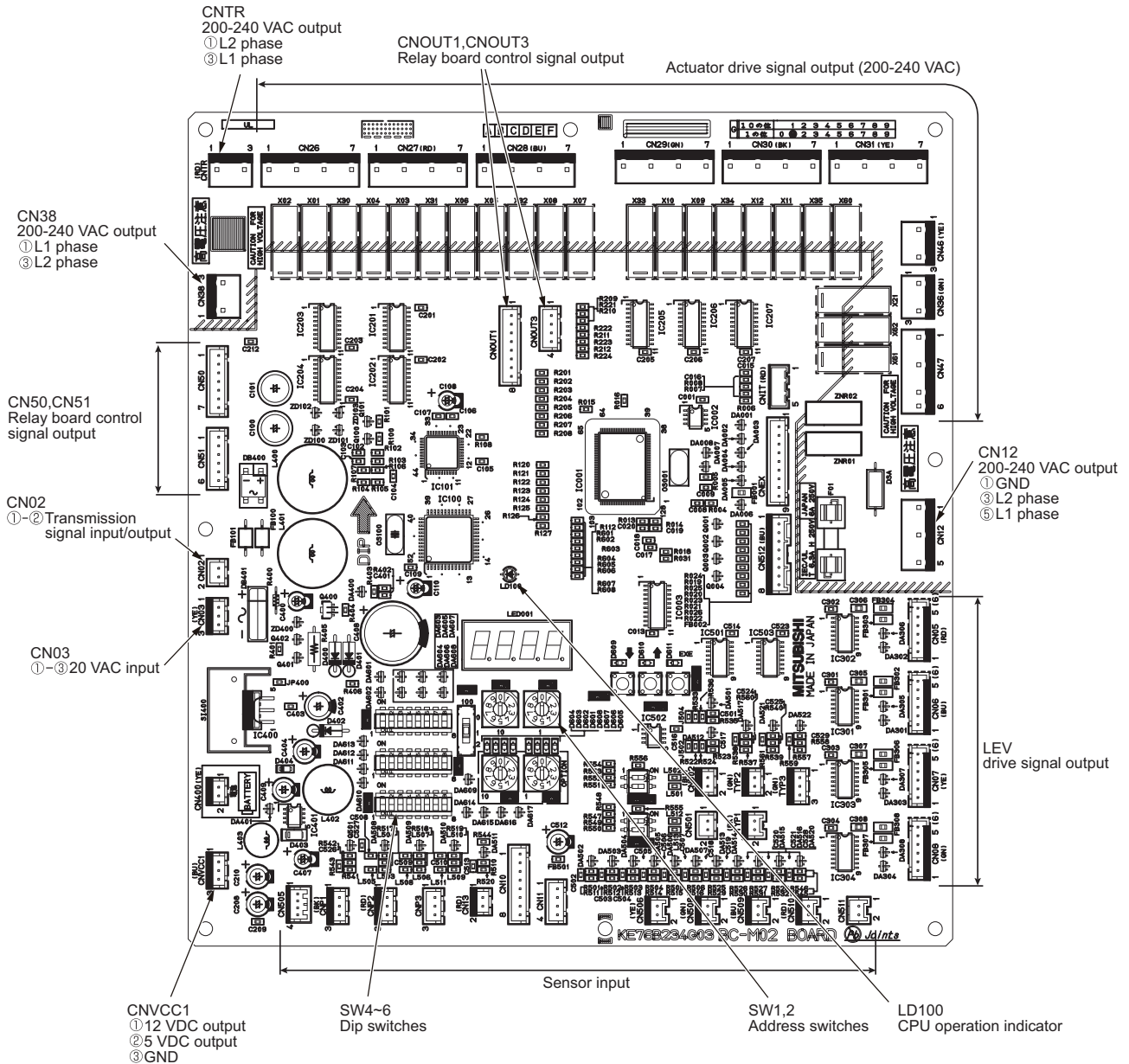

2. RELAY BOARD (RELAY 4 board)

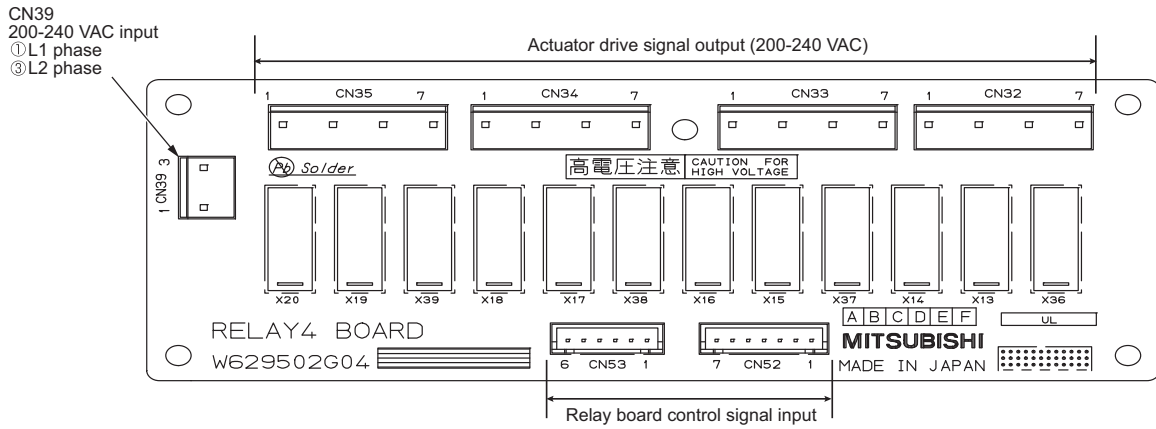

3. RELAY BOARD (RELAY 10 board)

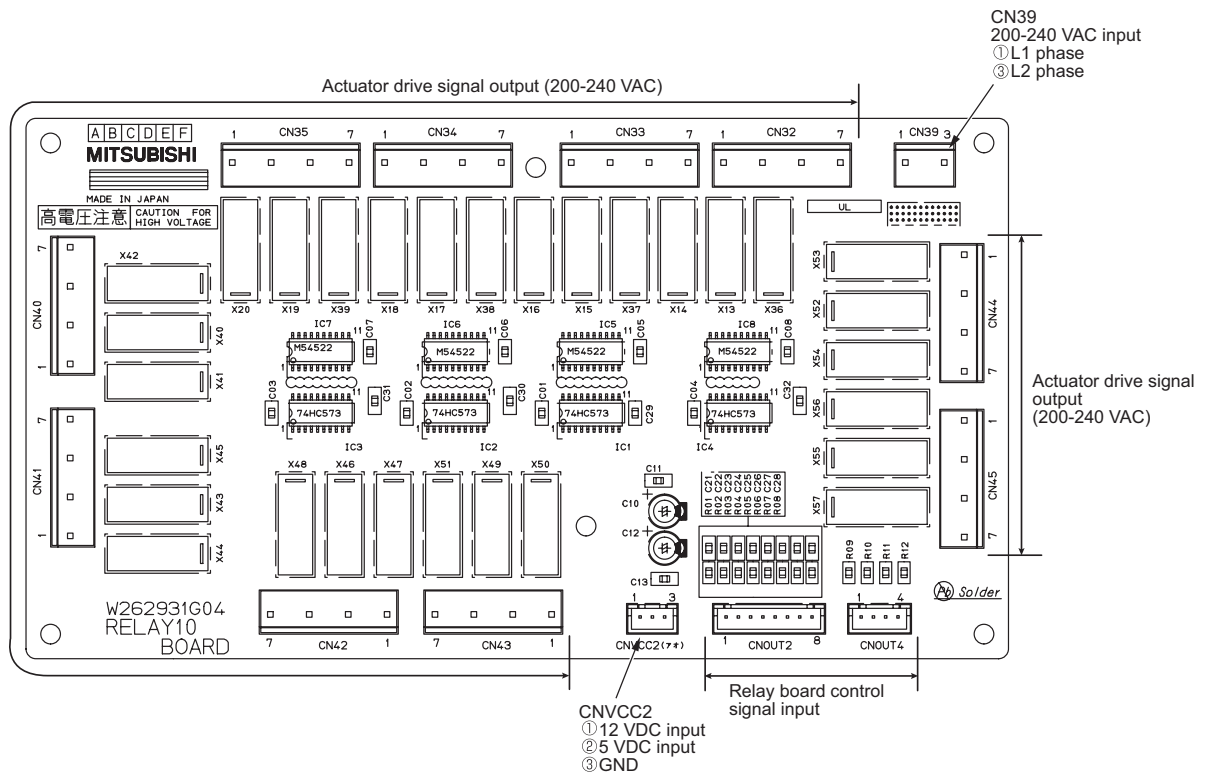

IV Remote Controller

[1] Functions and Specifications of MA and ME Remote Controllers	113
[2] Group Settings and Interlock Settings via the ME Remote Controller	114
[3] Interlock Settings via the MA Remote Controller	118
[4] Using the built-in Temperature Sensor on the Remote Controller	119



[1] Functions and Specifications of MA and ME Remote Controllers

There are two types of remote controllers: ME remote controller, which is connected on the indoor-heat source transmission line, and MA remote controller, which is connected to each indoor unit.

1. Comparison of functions and specifications between MA and ME remote controllers

Functions/specifications	MA remote controller ^{*1*2}	ME remote controller ^{*2*3}
Remote controller address settings	Not required	Required
Indoor-heat source unit address settings	Not required (required only by a system with one heat source unit) ⁴	Required
Wiring method	Non-polarized 2-core cable *To perform a group operation, daisy-chain the indoor units using non-polarized 2-core cables.	Non-polarized 2-core cable
Remote controller connection	Connectable to any indoor unit in the group	Connectable anywhere on the indoor-heat source transmission line
Interlock with the ventilation unit	Each indoor unit can individually be interlocked with a ventilation unit. (Set up via remote controller in the group.)	Each indoor unit can individually be interlocked with a ventilation unit. (Set up via remote controller.)
Changes to be made upon grouping change	MA remote controller wiring between indoor units requires rewiring.	Either the indoor unit address and remote controller address must both be changed, or the registration information must be changed via MELANS.

- *1. MA remote controller refers to MA remote controller (PAR-20MAU, PAR-21MAAU, PAR-30MAAU), MA simple remote controller, and wireless remote controller.
- *2. Either the MA remote controller or the ME remote controller can be connected when a group operation of units in a system with multiple heat source units is conducted or when a system controller is connected.
- *3. ME remote controller refers to ME remote controller and ME simple remote controller.
- *4. Depending on the system configuration, some systems with one heat source unit may require address settings.

2. Remote controller selection criteria

MA remote controller and ME remote controller have different functions and characteristics. Choose the one that better suits the requirements of a given system. Use the following criteria as a reference.

MA remote controller ^{*1*2}	ME remote controller ^{*1*2}
<ul style="list-style-type: none"> ♦There is little likelihood of system expansion and grouping changes. ♦Grouping (floor plan) has been set at the time of installation. 	<ul style="list-style-type: none"> ♦There is a likelihood of centralized installation of remote controllers, system expansion, and grouping changes. ♦Grouping (floor plan) has not been set at the time of installation. ♦To connect the remote controller directly to the OA processing unit.

- *1. ME remote controller and MA remote controller cannot both be connected to the same group of indoor units.
- *2. A system controller must be connected to a system to which both MA remote controller and ME remote controller are connected.

<System with MA remote controller>

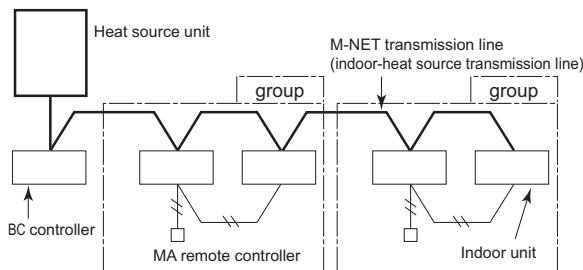

<System with ME remote controllers>

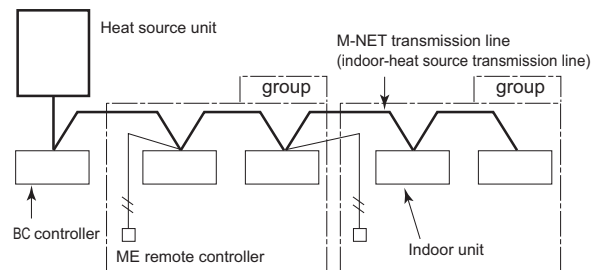

[2] Group Settings and Interlock Settings via the ME Remote Controller

1. Group settings/interlock settings

Make the following settings to perform a group operation of units that are connected to different heat source units or to manually set up the indoor/heat source unit address.

- (A) Group settings.....Registration of the indoor units to be controlled with the remote controller, and search and deletion of registered information.
- (B) Interlock settings.....Registration of LOSSNAY units to be interlocked with the indoor units, and search and deletion of registered information

[Operation Procedures]

(1) Address settings

Register the indoor unit to be controlled with the remote controller.

① Bring up either one of the following displays on the remote controller:

The blinking display of "HO," which appears when the power is turned on, or the normal display, which appears when the unit is stopped. The display window must look like one of the two figures below to proceed to the next step.

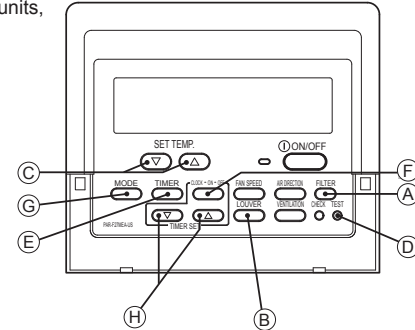

(A) Group Settings

② Bring up the "Group Setting" window.

- Press and hold buttons (A) [FILTER] and (B) [LOUVER] simultaneously for 2 seconds to bring up the display as shown below.

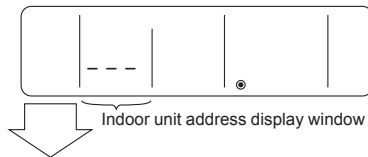

③ Select the unit address.

- Select the address of the indoor unit to be registered by pressing button (C) [SET TEMP. (▽) or (△)] to advance or go back through the addresses.

④ Register the indoor unit whose address appears on the display.

- Press button (D) [TEST] to register the indoor unit address whose address appears on the display.
- If registration is successfully completed, unit type will appear on the display as shown in the figure below.
- If the selected address does not have a corresponding indoor unit, an error message will appear on the display. Check the address, and try again.

<Successful completion of registration>

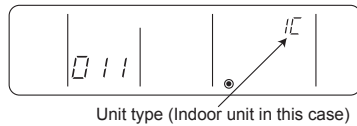

<Deletion error>

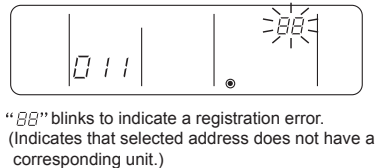

⑤ To register the addresses for multiple indoor units, repeat steps ③ and ④ above.

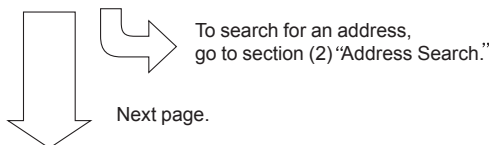

(B) Interlock Settings

⑥ Bring up the "Interlock Setting" window.

- Press button (C) [MODE] to bring up the following display. Press again to go back to the "Group Setting" window as shown under step ②.

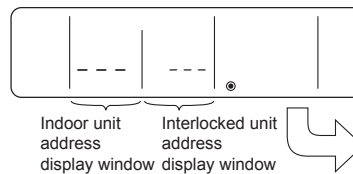

Both the "indoor unit address" and "interlocked unit address" will be displayed together.

To search for an address, go to section (2) "Address Search."

⑦ Bring up the address of the indoor unit and the address of the LOSSNAY to be interlocked on the display.

- Select the address of the indoor unit to be registered by pressing button (C) [SET TEMP. (▽) or (△)] to advance or go back through the addresses.
- Select the address of the LOSSNAY unit to be interlocked by pressing button (H) [TIMER SET (▽) or (△)] to advance or go back through the "interlocked unit addresses."



⑧ Make the settings to interlock LOSSNAY units with indoor units.

- Press button (D) [TEST] while both the indoor unit address and the address of the LOSSNAY units to be interlocked are displayed to enter the interlock setting.
- Interlock setting can also be made by bringing up the LOSSNAY address in the indoor unit address display window and the indoor unit address in the interlocked unit address display window.



If registration is successfully completed, the two displays as shown on the left will appear alternately. If the registration fails, "BB" will blink on the display. (Indicates that the selected address does not have a corresponding unit.)

NOTE : Interlock all the indoor units in the group with the LOSSNAY units; otherwise, the LOSSNAY units will not operate.

(C) To return to the normal display

When all the group settings and interlock settings are made, take the following step to go back to the normal display.

- ⑩ Press and hold buttons **A [FILTER]** and **B [LOUVER]** simultaneously for 2 seconds to go back to the window as shown in step ①.

(2) Address search

To search for the address of indoor units that have been entered into the remote controller, follow steps ① and ②.

(A) To search group settings

⑪ Bring up the "Group Setting" window.

- Each pressing of button **E [TIMER]** will bring up the address of a registered indoor unit and its unit type on the display.

<Entry found>

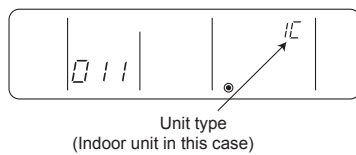

<No entries found>



- When only one unit address is registered, the same address will remain on the display regardless of how many times the button is pressed.
- When the address of multiple units are registered (i.e. "011", "012", "013"), they will be displayed one at a time in an ascending order with each pressing of button **E [TIMER]**.

To go back to the normal display, follow step ⑩

To delete an address, go to section (3) "Address Deletion."

(3) Address deletion

The addresses of the indoor units that have been entered into the remote controller can be deleted by deleting the group settings.

The interlock settings between units can be deleted by deleting the interlock settings.

Follow the steps in section (2) "Address Search" to find the address to be deleted and perform deletion with the address being displayed in the display window. To delete an address, the address must first be brought up on the display.

⑮ Delete the registered indoor unit address or the interlock setting between units.

- Press button **F [CLOCK→ON→OFF]** twice while either the indoor unit address or the address of the interlocked unit is displayed on the display to delete the interlock setting.

⑨ Repeat steps ⑦ and ⑧ in the previous page to interlock all the indoor units in a group with the LOSSNAY unit.

To go back to the normal display, follow step ⑩

To search for an address, go to section (2) "Address Search."

(B) Interlock setting search

After performing step ⑥, proceed as follows:

⑫ Bring up the address of the indoor unit to be searched on the display.

- Select the address of the indoor unit to be searched by pressing button **H [TIMER SET (▽) or (△)]** to advance or go back through the interlocked addresses.



LOSSNAY can be searched in the same manner by bringing up the LOSSNAY address in the Interlocked unit address display window.

⑬ Bring up on the display the address of the LOSSNAY unit that was interlocked with the indoor unit in step ⑫.

- With each pressing of button **E [TIMER]**, the address of the LOSSNAY and indoor unit that is interlocked with it will be displayed alternately.

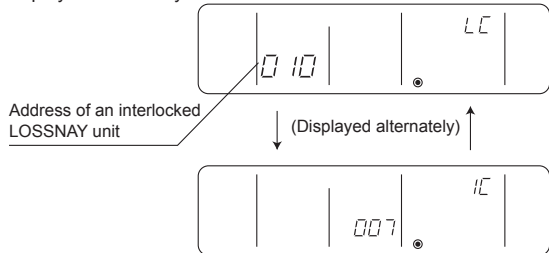

⑭ Bring up the address of another registered unit on the display.

- After completing step ⑬, a subsequent pressing of button **E [TIMER]** will bring up the address of another registered unit.

(The display method is the same as the one in step ⑬.)

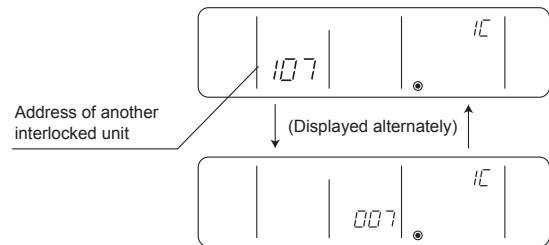

To delete an address, go to section (3) "Address Deletion."

(A) To delete group settings

<Successful completion of deletion>

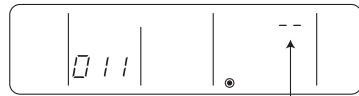

"--" will be displayed in the room temperature display window.

- If a transmission error occurs, the selected setting will not be deleted, and the display will appear as shown below. In this case, repeat the steps above.

<Deletion error>

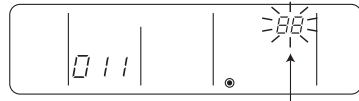

"88" will be displayed in the room temperature display window.

To go back to the normal display, follow step ⑩.

(B) To delete interlock settings



(Displayed alternately)

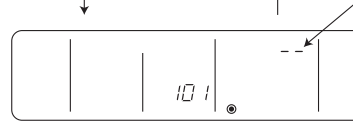

If deletion is successfully completed, "--" will appear in the unit type display window. If the deletion fails, "88" will appear in the unit type display window. In this case, repeat the steps above.

(4) Making (A) Group settings and (B) Interlock settings of a group from any arbitrary remote controller

(A) Group settings and (B) Interlock settings of a group can be made from any arbitrary remote controller. Refer to "(B) Interlock Settings" under section 1 "Group Settings/Interlock Settings" for operation procedures. Set the address as shown below.

(A) To make group settings

Interlocked unit address display window...Remote controller address
Indoor unit address display window.....The address of the indoor unit to be controlled with the remote controller

(B) To make interlock settings

Interlocked unit address display window...LOSSNAY address
Indoor unit address display window.....The address of the indoor unit to be interlocked with the LOSSNAY

2. Remote controller function selection via the ME remote controller

In the remote controller function selection mode, the settings for three types of functions can be made or changed as necessary.

1) Operation mode display selection mode (Display or non-display of COOL/HEAT during automatic operation mode)

When the automatic operation mode is selected, the indoor unit will automatically perform a cooling or heating operation based on the room temperature. In this case, "AUTO COOL" or "AUTO HEAT" will appear on the remote controller display. This setting can be changed so that only "AUTO" will appear on the display.

2) Room temperature display selection mode (Display or non-display of room temperature)

Although the suction temperature is normally displayed on the remote controller, the setting can be changed so that it will not appear on the remote controller.

3) Narrowed preset temperature range mode

The default temperature ranges are 67°F to 87°F in the cooling/dry mode and 63°F to 83°F in the heating mode.

By changing these ranges (raising the lower limit for the cooling/dry mode and lowering the upper limit for the heating mode), energy can be saved.

*The settable range varies depending on the unit to be connected.

NOTE

On the PAR-F27MEA-US model, automatic operation mode cannot be selected while the unit is in the narrowed preset temperature range mode. Only the lower limit can be set for cooling/dry mode, and upper limit for heating mode.

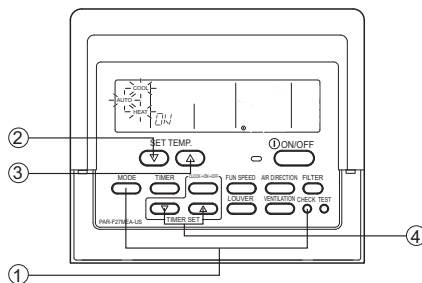

[Function selection mode sequence on the remote controller]

Normal Display (Stopped unit)

① ↑ ↓ ①

Remote controller function selection mode

Operation mode display selection mode

③ ↑ ↓ ②

Room temperature display selection mode

③ ↑ ↓ ②

Narrowed preset temperature range mode (cooling/dry mode)

③ ↑ ↓ ②

Narrowed preset temperature range mode (heating mode)



[Normal display]

①: Press and hold the [CHECK] and [MODE] buttons simultaneously for two seconds.

②: [SET TEMP. (▽)] button

③: [SET TEMP. (△)] button

[Operation Procedures]

1. Press the [ON/OFF] button on the remote controller to bring the unit to a stop. The display will appear as shown in the previous page (Normal display).
2. Press buttons ① [CHECK] and [MODE] simultaneously for 2 seconds to go into the “operation mode display selection mode” under the remote controller function selection mode. Press button ② [SET TEMP. (▽)] or ③ [SET TEMP. (△)] to go into the other three modes under the remote controller function selection mode.

Operation mode display selection mode (Display or non-display of room temperature on the remote controller.)

• “AUTO” “COOL/HEAT” will blink, and either “ON” or “OFF” will light up. Press button ④ [TIMER SET (△) or (▽)] in this state to switch between “ON” and “OFF.”



- When it is set to “ON,” “AUTO” and “COOL” or “AUTO” and “HEAT” will appear on the display during automatic operation mode.
- When it is set to “OFF,” only “AUTO” will appear on the display during automatic operation mode.

Room temperature display selection mode (Display or non-display of room temperature)

• “88°F” will blink in the room temperature display window, and either “ON” or “OFF” will light up. Press button ④ [TIMER SET (△) or (▽)] in this state to switch between “ON” and “OFF.”



- When it is set to “ON,” the room temperature will stay in the operation display window during operation.
- When it is set to “OFF,” the room temperature will not appear in the operation display window during operation.

Narrowed preset temperature range mode (The range of preset temperature can be changed.)

1) Temperature range setting for the cooling/dry mode

“COOL/DRY” and “LIMIT TEMP.” will light up in the display window, and the temperature range for the cooling/dry mode will appear on the display. The lower limit temperature will be blinking in the preset temperature display window. While it is blinking, the temperature setting can be changed.
 [Selection range for the lower limit temperature] : 67°F ↔ 87°F (Medium temperature range indoor unit 57°F ↔ 87°F)
 (The upper limit temperature is fixed at 87°F. Only the lower limit temperature is changeable.)

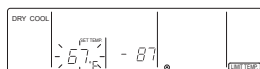

[When the temperature range for the cooling or dry mode is set to 67°F to 87°F]

- 2) Press button ④ [TIMER SET (△) or (▽)] to set the lower limit temperature to the desired temperature.

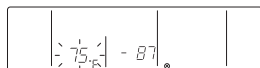

[When the temperature range is changed to 75°F - 87°F]

- 3) After completing the step above, press button ② [SET TEMP. (▽)] to go into the temperature range setting mode to set the temperature range for the heating operation.

“HEAT” and “LIMIT TEMP.” will light up, and the temperature range for the heating mode will appear on the screen.

The upper limit temperature can be changed with button ④ [TIMER SET (△) or (▽)].

[Selection range for the upper limit temperature] : 63°F ↔ 83°F (Medium temperature range indoor unit 63°F ↔ 83°F)

(The lower limit temperature is fixed at 63°F. Only the upper limit temperature is changeable.)

3. When all the necessary settings have been made, exit the remote controller function selection mode and go back to the Normal display by pressing and holding buttons ① [CHECK] and [MODE] simultaneously for 2 seconds.

[3] Interlock Settings via the MA Remote Controller

1. LOSSNAY interlock setting (Make this setting only when necessary.)

* When the upper controller is connected, make the setting using the upper controller.

NOTE: When using LOSSNAY units in conjunction, interlock the addresses of all indoor units within the group and address of LOSSNAY units.

Perform this operation to enter the interlock setting between the LOSSNAY and the indoor units to which the remote controller is connected, or to search and delete registered information.

In the following example, the address of the indoor unit is 05 and the address of the LOSSNAY unit is 30.

[Operation Procedures]

- ① Press the [ON/OFF] button on the remote controller to bring the unit to a stop.
The display window on the remote controller must look like the figure below to proceed to step ②.



- ② Press and hold the [FILTER] and [] buttons simultaneously for two seconds to perform a search for the LOSSNAY that is interlocked with the indoor unit to which the remote controller is connected.



- ③ Search result
- The indoor unit address and the interlocked LOSSNAY address will appear alternately.

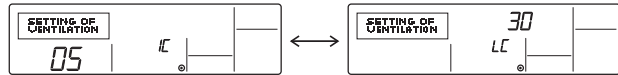

<Indoor unit address and indoor unit> <LOSSNAY address and LOSSNAY>

- Without interlocked LOSSNAY settings

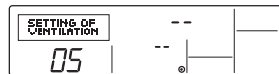

- ④ If no settings are necessary, exit the window by pressing and holding the [FILTER] and [] buttons simultaneously for 2 seconds.
Go to step 1. **Registration Procedures** to make the interlock settings with LOSSNAY units, or go to step 2. **Search Procedures** to search for a particular LOSSNAY unit.
Go to step 3. **Deletion Procedures** to delete any LOSSNAY settings.

< 1. Registration Procedures >

- ⑤ To interlock an indoor unit with a LOSSNAY unit, press the [TEMP. (▽) or (△)] button on the remote controller that is connected to the indoor unit, and select its address (01 to 50).
- ⑥ Press the [CLOCK (▽) or (△)] button to select the address of the LOSSNAY to be interlocked (01 to 50).

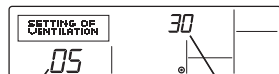

Indoor unit address LOSSNAY address

- ⑦ Press the [TEST] button to register the address of the selected indoor unit and the interlocked LOSSNAY unit.
- Registration completed
The registered indoor unit address and "IC," and the interlocked LOSSNAY address and "LC" will appear alternately.

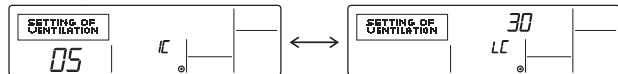

- Registration error

If the registration fails, the indoor unit address and the LOSSNAY address will be displayed alternately.

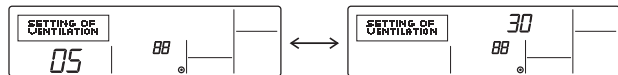

Registration cannot be completed: The selected unit address does not have a corresponding indoor unit or a LOSSNAY unit.
Registration cannot be completed: Another LOSSNAY has already been interlocked with the selected indoor unit.

2. Search Procedures >

⑧ To search for the LOSSNAY unit that is interlocked with a particular indoor unit, enter the address of the indoor unit into the remote controller that is connected to it.

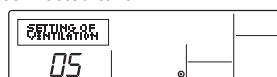

<Indoor unit address>

⑨ Press the [MENU] button to search for the address of the LOSSNAY unit that is interlocked with the selected indoor unit.

- Search completed (With a LOSSNAY connection)

The indoor unit address and "IC," and the interlocked LOSSNAY address and "LC" will appear alternately.

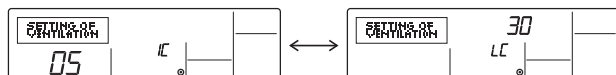

- Search completed (No interlocked settings with a LOSSNAY exist.)



- The selected address does not have a corresponding indoor unit.

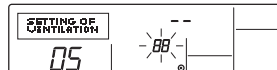

3. Deletion Procedures >

Take the following steps to delete the interlock setting between a LOSSNAY unit and the interlocked indoor unit from the remote controller that is connected to the indoor unit.

⑩ Find the address of the LOSSNAY to be deleted (See section 2. Search Procedures.), and bring up the result of the search for both the indoor unit and LOSSNAY on the display.

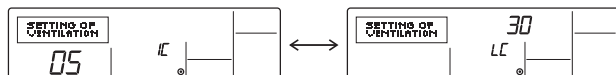

⑪ Press the [ON/OFF] button twice to delete the address of the LOSSNAY unit that is interlocked with the selected indoor unit.

- Registration completed

The indoor unit address and "--," and the interlocked LOSSNAY address and "--" will appear alternately.

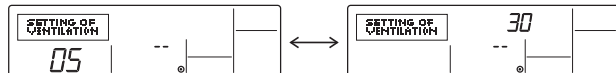

-Deletion error

If the deletion fails

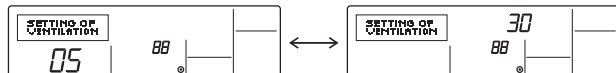

[4] Using the built-in Temperature Sensor on the Remote Controller

1. Selecting the position of temperature detection (Factory setting: SW1-1 on the controller board on the indoor unit is set to OFF.)

To use the built-in sensor on the remote controller, set the SW1-1 on the controller board on the indoor unit to ON.

- ◆ Some models of remote controllers are not equipped with a built-in temperature sensor. Use the built-in temperature sensor on the indoor unit instead.
- ◆ When using the built-in sensor on the remote controller, install the remote controller where room temperature can be detected.

V Electrical Wiring Diagram

- [1] Electrical Wiring Diagram of the Heat source Unit..... 123
- [2] Electrical Wiring Diagram of the BC Controller 127
- [3] Electrical Wiring Diagram of Transmission Booster..... 137



[1] Electrical Wiring Diagram of the Heat source Unit

(1) PQHY-P72, 96, 120TLMU-A1, PQRY-P72, 96, 120TLMU-A1

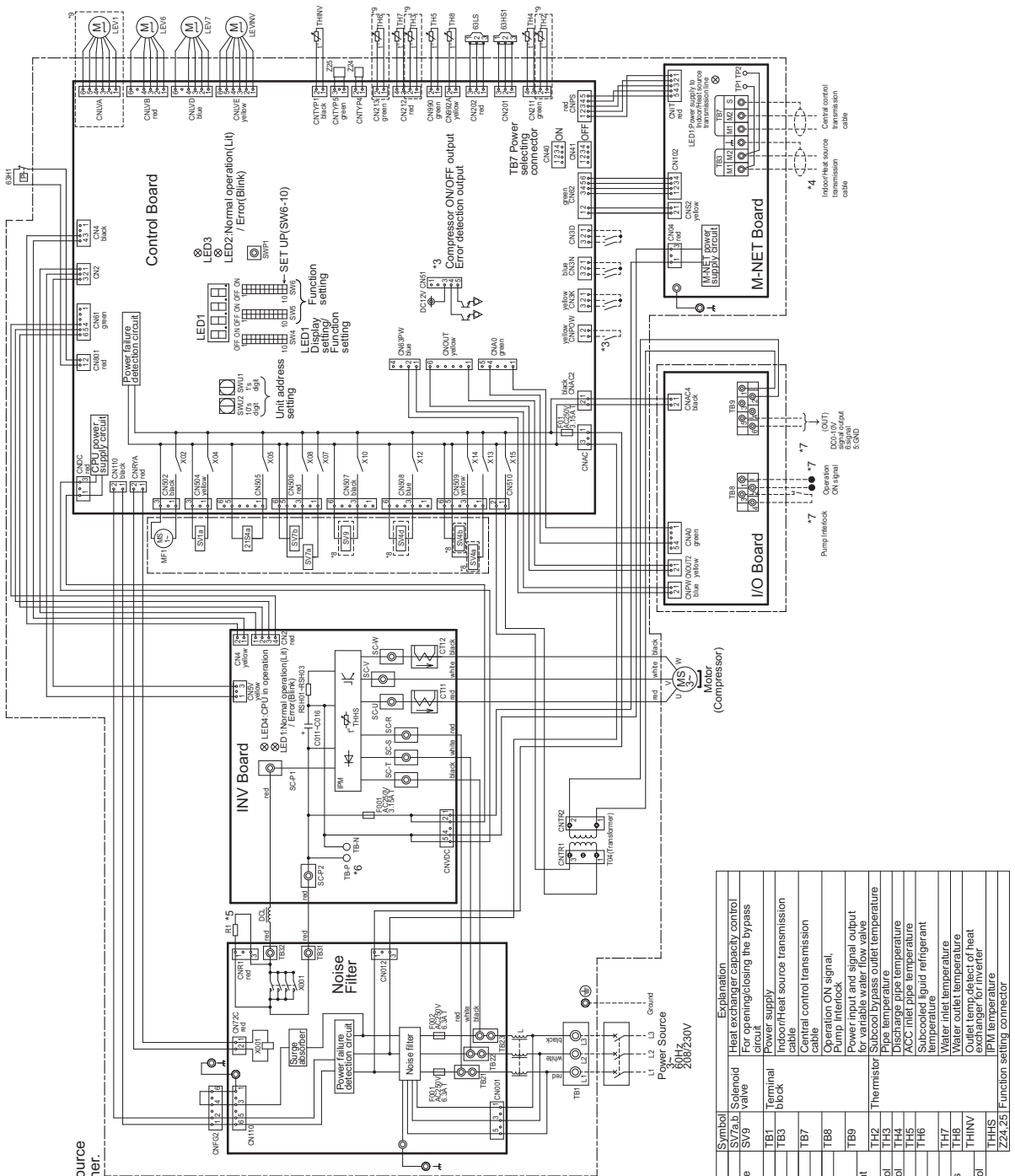

- *1. Single-dotted lines indicate wiring not supplied with the unit.
- *2. Dot-dash lines indicate the control box boundaries.
- *3. Refer to the Data book for connecting input/output signal connectors.
- *4. Daisy-chain terminals (TB3) on the heat source units in the same refrigerant system together.
- *5. Faston terminals have a locking function. Make sure the terminals are securely locked in place after insertion. Press the tab on the terminals to removed them.
- *6. Control box houses high-voltage parts. Before inspecting the inside of the control box turn off the power, keep the unit off for at least 10 minutes, and confirm that the voltage between TB-P and TB-N on INV Board has dropped to DC20V or less.
- *7. Refer to the Data book for wiring terminal block for Pump Interlock, Operation ON signal and DC0-10V signal output.
- *8. Difference of appliance.
- *9. Difference of appliance.

Model name	Appliance
PQHY	*8 do not exist
PQRY	*8 exist
Model name	Appliance
PQHY	*9 exist
PQRY	*9 do not exist

<Symbol explanation>

Symbol	Explanation
Z1, S4a	4-way valve
21, S4a	Cooling/Heating switching
63H1	Pressure switch
63H51	High pressure protection for the heat source unit
63H51	High pressure sensor
X001	Magnetic relay (inverter main circuit)
X011~X016	Capacitor (inverter main circuit)
CT11, 12	Current sensor (AC)
DCL	DC reactor
L	Choke coil (for high frequency noise reduction)
LEV1	HIC bypass
LEV6	Controls refrigerant expansion valve
LEV7	Heat exchanger capacity control valve
LEV/V	Heat exchanger capacity control
MF1	Heat exchanger for inverter
RF1	Fan motor (Radiator panel)
RS1~RS5	Resistor
SV1a	For current detection
SV1a	For current detection of the bypass circuit under the OS
SV1a,b,d	Solenoid valve
SV1a,b,d	Heat exchanger capacity control
SV7a,b	Function setting connector
SV9	Solenoid valve
TB1	Terminal block
TB3	Power supply
TB5	Terminal block
TB7	Terminal block
TB8	Terminal block
TB9	Terminal block
TH2	Thermistor
TH3	Thermistor
TH4	Thermistor
TH5	Thermistor
TH6	Thermistor
TR1	Transformer
TR2	Transformer
TR3	Transformer
TR4	Transformer
TR5	Transformer
TR6	Transformer
TR7	Transformer
TR8	Transformer
TR9	Transformer
TR10	Transformer
TR11	Transformer
TR12	Transformer
TR13	Transformer
TR14	Transformer
TR15	Transformer
TR16	Transformer
TR17	Transformer
TR18	Transformer
TR19	Transformer
TR20	Transformer
TR21	Transformer
TR22	Transformer
TR23	Transformer
TR24	Transformer
TR25	Transformer
TR26	Transformer
TR27	Transformer
TR28	Transformer
TR29	Transformer
TR30	Transformer
TR31	Transformer
TR32	Transformer
TR33	Transformer
TR34	Transformer
TR35	Transformer
TR36	Transformer
TR37	Transformer
TR38	Transformer
TR39	Transformer
TR40	Transformer
TR41	Transformer
TR42	Transformer
TR43	Transformer
TR44	Transformer
TR45	Transformer
TR46	Transformer
TR47	Transformer
TR48	Transformer
TR49	Transformer
TR50	Transformer
TR51	Transformer
TR52	Transformer
TR53	Transformer
TR54	Transformer
TR55	Transformer
TR56	Transformer
TR57	Transformer
TR58	Transformer
TR59	Transformer
TR60	Transformer
TR61	Transformer
TR62	Transformer
TR63	Transformer
TR64	Transformer
TR65	Transformer
TR66	Transformer
TR67	Transformer
TR68	Transformer
TR69	Transformer
TR70	Transformer
TR71	Transformer
TR72	Transformer
TR73	Transformer
TR74	Transformer
TR75	Transformer
TR76	Transformer
TR77	Transformer
TR78	Transformer
TR79	Transformer
TR80	Transformer
TR81	Transformer
TR82	Transformer
TR83	Transformer
TR84	Transformer
TR85	Transformer
TR86	Transformer
TR87	Transformer
TR88	Transformer
TR89	Transformer
TR90	Transformer
TR91	Transformer
TR92	Transformer
TR93	Transformer
TR94	Transformer
TR95	Transformer
TR96	Transformer
TR97	Transformer
TR98	Transformer
TR99	Transformer
TR100	Transformer

(2) PQHY-P144, 168, 192TLMU-A1, PQRY-P144, 168, 192TLMU-A1

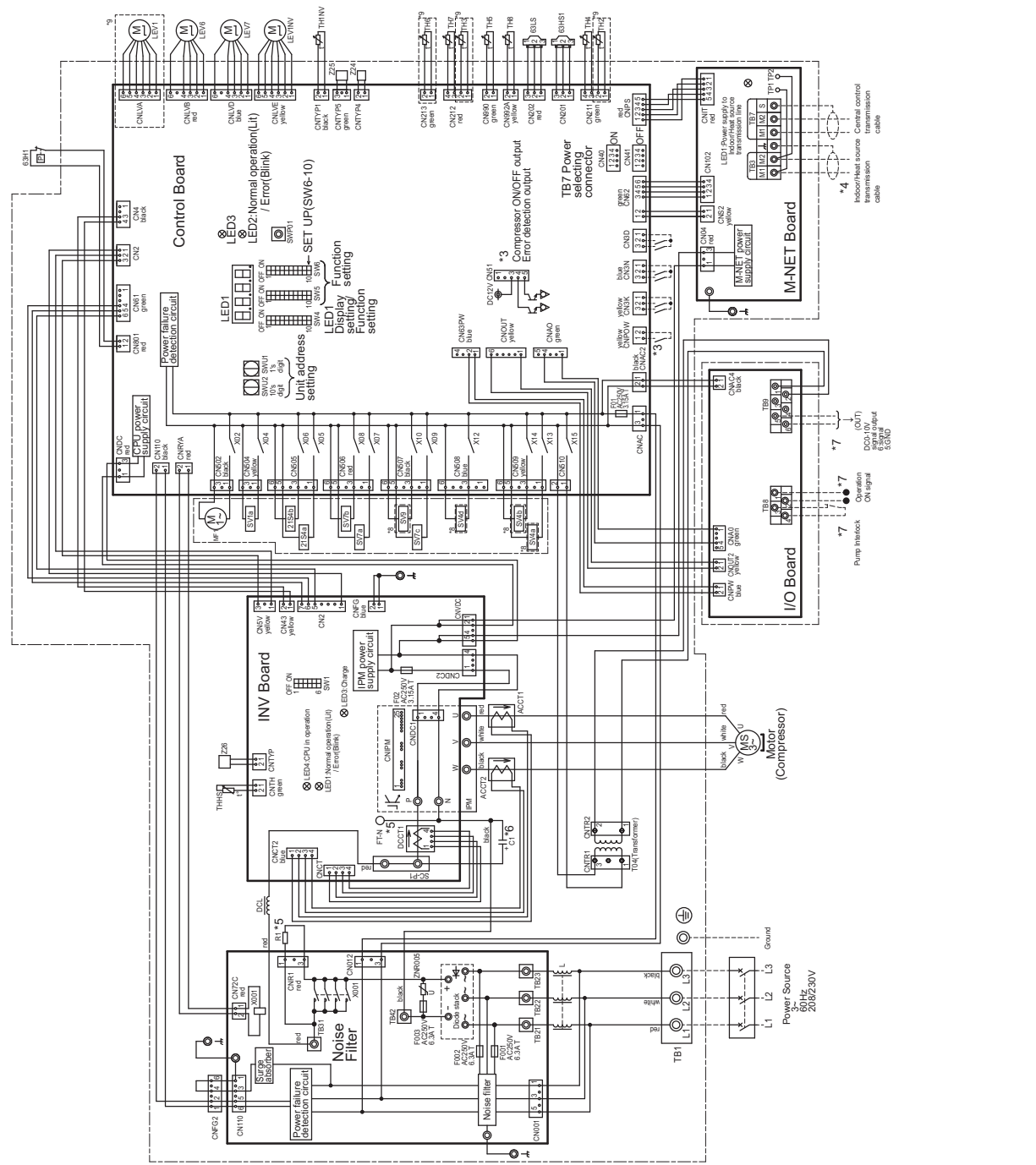

- *1. Single-dotted lines indicate wiring not supplied with the unit.
- *2. Dot-dash lines indicate the control box boundaries.
- *3. Refer to the Data book for connecting input/output signal connectors.
- *4. Daisy-chain terminals (TB3) on the heat source units in the same refrigerant system together.
- *5. Faston terminals have a locking function. Make sure the terminals are securely locked in place after insertion. Press the tab on the terminals to removed them.
- *6. Control box houses high-voltage parts. Before inspecting the inside of the control box, turn off the power, keep the unit off for at least 10 minutes, and confirm that the voltage at both ends of the main capacitor (C1) has dropped to DC20V or less.
- *7. Refer to the Databook for wiring terminal block for Pump Interlock/Operation ON signal and DC0-10V signal output.
- *8. Difference of appliance.
- Model name Appliance
PQHY *8 do not exist
PQRY *8 exist
- *9. Difference of appliance.
- Model name Appliance
PQHY *9 exist
PQRY *9 do not exist

<Symbol explanation>

Symbol	Explanation
21S4b	4-way valve (Cooling/Heating switching)
21S4b	Heat exchanger capacity control
63H1	Pressure High pressure protection for the heat source unit
63HS1	Pressure High pressure
90L5	Pressure Low pressure
90L5	Magnetic relay (main circuit)
C1	Capacitor (inverter main circuit)
ACCT.1.2	Current sensor (AC)
DCCT1	Current sensor (DC)
DCI	Choke coil (for high frequency noise reduction)
LEV1	HFC bypass Controls refrigerant expansion
LEV6	Heat exchanger capacity control
LEV7	Heat exchanger capacity control
LEV7	Heat exchanger for inverter
MF1	Fan motor (Radiator panel)
RT1	Resistor For inrush current prevention
SV1a	Solenoid Valve
SV4a,b,d	Heat exchanger capacity control
SV7a,b,c	Heat exchanger capacity control
SV9	For opening/closing the bypass circuit
TB1	Terminal block
TB3	Power supply inverter/Heat source transmission cable
TB7	Central control transmission cable
TB8	Operation ON signal, Pump Interlock
TB9	Power input and signal output for variable water flow valve
TH2	Thermistor Heat source outlet temperature
TH3	Thermistor Pipe temperature
TH4	Discharge pipe temperature
TH5	ACC inlet pipe temperature
TH6	Subcooled liquid refrigerant temperature
TH7	Water inlet temperature
TH8	Water outlet temperature
TH9	Water inlet temperature for heat exchanger for inverter
TH10	Water outlet temperature for heat exchanger for inverter
TH15	IPM temperature
Z24,25,26	Function setting connector

(3) PQHY-P216, 240TLMU-A1, PQRV-P216, 240TLMU-A1

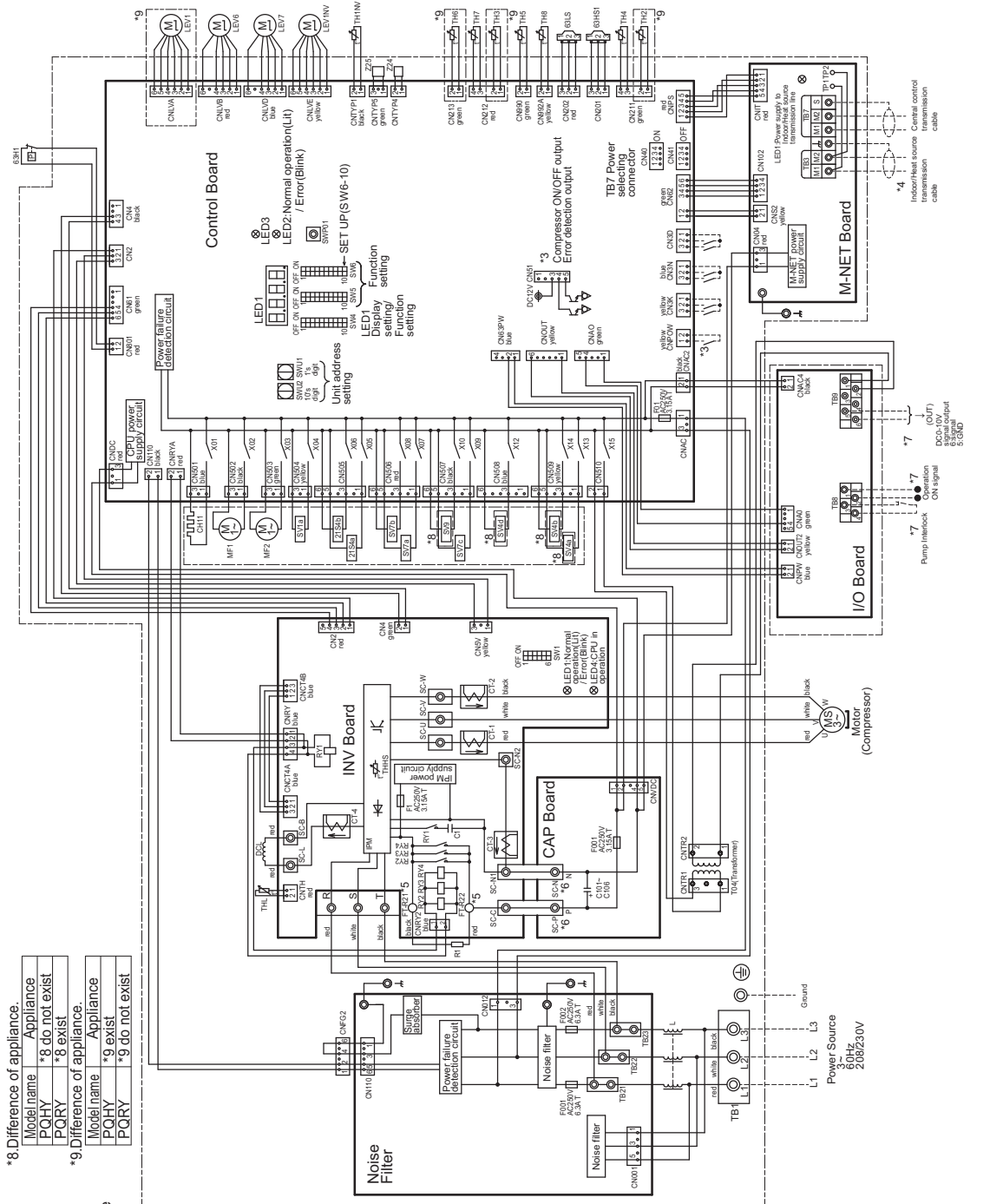

- *8. Difference of appliance.

Model name	Appliance
PQHY	*8 do. not exist
PQRY	*8 exist
- *9. Difference of appliance.

Model name	Appliance
PQHY	*9 exist
PQRY	*9 do. not exist

- *1 Single-dotted lines indicate wiring not supplied with the unit.
- *2 Dot-dash lines indicate the control box boundaries.
- *3 Refer to the Data book for connecting input/output signal connectors.
- *4 Daisy-chain terminals (TB3) on the heat source units in the same refrigerant system together.
- *5 Fasten terminals have a locking function. Make sure the terminals are securely locked in place after insertion. Press the tab on the terminals to removed them.
- *6 Control box houses high-voltage parts. Before inspecting the inside of the control box, turn off the power, keep the unit off for at least 10 minutes, and confirm that the voltage between SC-P and SC-N on CAP Board has dropped to DC20V or less.
- *7 Refer to the Data book for wiring terminal block for Pump Interlock, Operation ON signal and DC0-10V signal output.

<Symbol explanation>

Symbol	Explanation
Z1S4a	4-way valve
Z1S4b	Cooling/Heating switching
63H1	Heat exchanger capacity control
63H2	Pressure switch
63H3	High pressure protection for the heat source unit
63H4	Pressure switch
63H5	High pressure
63H6	Pressure
63H7	Low pressure
63H8	Pressure
63H9	Capacitor
C101-C106	Compressor
CH11	Crankcase heater(for heating the compressor)
CT-1,CT-2	Current sensor(AC)
CT-3,CT-4	Current sensor(DC)
DCL	DC reactor
L	Check coil(for high frequency noise)
LEV1	Linear valve
LEV6	H/C bypass Controls refrigerant flow in H/C circuit
LEV7	Heat exchanger capacity control
LEV8	Heat exchanger capacity control
LEV9	Heat exchanger capacity control
MF1-MF2	Heat exchanger capacity control
RV1	Fan motor(loadator panel)
RV2, RV3, RV4	Relay
SV1a	Solenoid valve
SV4a, b, d	For opening/closing the bypass circuit under the O/S
SV7a, b, c	Heat exchanger capacity control
SV9	Heat exchanger capacity control
SV9	For opening/closing the bypass circuit
TB1	Terminal block
TB3	Indoor/Heat source transmission cable
TB7	Central control transmission cable
TB8	Operation ON signal, Power input and signal output for variable water flow valve
TB9	Power input and signal output for variable water flow valve
TH2	Thermistor
TH3	Subcool bypass outlet temperature
TH4	Pipe temperature
TH5	Discharge pipe temperature
TH6	ACC inlet pipe temperature
TH7	Evaporator liquid refrigerant temperature
TH8	Water inlet temperature
TH9	Water outlet temperature
TH10	Outlet temp. detect of heat exchanger for inverter
TH11	Water inlet temperature
TH12	Water outlet temperature
TH13	Water inlet temperature
TH14	Water outlet temperature
TH15	Water inlet temperature
TH16	Water outlet temperature
TH17	Water inlet temperature
TH18	Water outlet temperature
TH19	Water inlet temperature
TH20	Water outlet temperature
TH21	Water inlet temperature
TH22	Water outlet temperature
TH23	Water inlet temperature
TH24	Water outlet temperature
TH25	Water inlet temperature
TH26	Water outlet temperature
TH27	Water inlet temperature
TH28	Water outlet temperature
TH29	Water inlet temperature
TH30	Water outlet temperature
TH31	Water inlet temperature
TH32	Water outlet temperature
TH33	Water inlet temperature
TH34	Water outlet temperature
TH35	Water inlet temperature
TH36	Water outlet temperature
TH37	Water inlet temperature
TH38	Water outlet temperature
TH39	Water inlet temperature
TH40	Water outlet temperature
TH41	Water inlet temperature
TH42	Water outlet temperature
TH43	Water inlet temperature
TH44	Water outlet temperature
TH45	Water inlet temperature
TH46	Water outlet temperature
TH47	Water inlet temperature
TH48	Water outlet temperature
TH49	Water inlet temperature
TH50	Water outlet temperature
TH51	Water inlet temperature
TH52	Water outlet temperature
TH53	Water inlet temperature
TH54	Water outlet temperature
TH55	Water inlet temperature
TH56	Water outlet temperature
TH57	Water inlet temperature
TH58	Water outlet temperature
TH59	Water inlet temperature
TH60	Water outlet temperature
TH61	Water inlet temperature
TH62	Water outlet temperature
TH63	Water inlet temperature
TH64	Water outlet temperature
TH65	Water inlet temperature
TH66	Water outlet temperature
TH67	Water inlet temperature
TH68	Water outlet temperature
TH69	Water inlet temperature
TH70	Water outlet temperature
TH71	Water inlet temperature
TH72	Water outlet temperature
TH73	Water inlet temperature
TH74	Water outlet temperature
TH75	Water inlet temperature
TH76	Water outlet temperature
TH77	Water inlet temperature
TH78	Water outlet temperature
TH79	Water inlet temperature
TH80	Water outlet temperature
TH81	Water inlet temperature
TH82	Water outlet temperature
TH83	Water inlet temperature
TH84	Water outlet temperature
TH85	Water inlet temperature
TH86	Water outlet temperature
TH87	Water inlet temperature
TH88	Water outlet temperature
TH89	Water inlet temperature
TH90	Water outlet temperature
TH91	Water inlet temperature
TH92	Water outlet temperature
TH93	Water inlet temperature
TH94	Water outlet temperature
TH95	Water inlet temperature
TH96	Water outlet temperature
TH97	Water inlet temperature
TH98	Water outlet temperature
TH99	Water inlet temperature
TH100	Water outlet temperature
TH101	Water inlet temperature
TH102	Water outlet temperature
TH103	Water inlet temperature
TH104	Water outlet temperature
TH105	Water inlet temperature
TH106	Water outlet temperature
TH107	Water inlet temperature
TH108	Water outlet temperature
TH109	Water inlet temperature
TH110	Water outlet temperature
TH111	Water inlet temperature
TH112	Water outlet temperature
TH113	Water inlet temperature
TH114	Water outlet temperature
TH115	Water inlet temperature
TH116	Water outlet temperature
TH117	Water inlet temperature
TH118	Water outlet temperature
TH119	Water inlet temperature
TH120	Water outlet temperature
TH121	Water inlet temperature
TH122	Water outlet temperature
TH123	Water inlet temperature
TH124	Water outlet temperature
TH125	Water inlet temperature
TH126	Water outlet temperature
TH127	Water inlet temperature
TH128	Water outlet temperature
TH129	Water inlet temperature
TH130	Water outlet temperature
TH131	Water inlet temperature
TH132	Water outlet temperature
TH133	Water inlet temperature
TH134	Water outlet temperature
TH135	Water inlet temperature
TH136	Water outlet temperature
TH137	Water inlet temperature
TH138	Water outlet temperature
TH139	Water inlet temperature
TH140	Water outlet temperature
TH141	Water inlet temperature
TH142	Water outlet temperature
TH143	Water inlet temperature
TH144	Water outlet temperature
TH145	Water inlet temperature
TH146	Water outlet temperature
TH147	Water inlet temperature
TH148	Water outlet temperature
TH149	Water inlet temperature
TH150	Water outlet temperature
TH151	Water inlet temperature
TH152	Water outlet temperature
TH153	Water inlet temperature
TH154	Water outlet temperature
TH155	Water inlet temperature
TH156	Water outlet temperature
TH157	Water inlet temperature
TH158	Water outlet temperature
TH159	Water inlet temperature
TH160	Water outlet temperature
TH161	Water inlet temperature
TH162	Water outlet temperature
TH163	Water inlet temperature
TH164	Water outlet temperature
TH165	Water inlet temperature
TH166	Water outlet temperature
TH167	Water inlet temperature
TH168	Water outlet temperature
TH169	Water inlet temperature
TH170	Water outlet temperature
TH171	Water inlet temperature
TH172	Water outlet temperature
TH173	Water inlet temperature
TH174	Water outlet temperature
TH175	Water inlet temperature
TH176	Water outlet temperature
TH177	Water inlet temperature
TH178	Water outlet temperature
TH179	Water inlet temperature
TH180	Water outlet temperature
TH181	Water inlet temperature
TH182	Water outlet temperature
TH183	Water inlet temperature
TH184	Water outlet temperature
TH185	Water inlet temperature
TH186	Water outlet temperature
TH187	Water inlet temperature
TH188	Water outlet temperature
TH189	Water inlet temperature
TH190	Water outlet temperature
TH191	Water inlet temperature
TH192	Water outlet temperature
TH193	Water inlet temperature
TH194	Water outlet temperature
TH195	Water inlet temperature
TH196	Water outlet temperature
TH197	Water inlet temperature
TH198	Water outlet temperature
TH199	Water inlet temperature
TH200	Water outlet temperature
TH201	Water inlet temperature
TH202	Water outlet temperature
TH203	Water inlet temperature
TH204	Water outlet temperature
TH205	Water inlet temperature
TH206	Water outlet temperature
TH207	Water inlet temperature
TH208	Water outlet temperature
TH209	Water inlet temperature
TH210	Water outlet temperature
TH211	Water inlet temperature
TH212	Water outlet temperature
TH213	Water inlet temperature
TH214	Water outlet temperature
TH215	Water inlet temperature
TH216	Water outlet temperature
TH217	Water inlet temperature
TH218	Water outlet temperature
TH219	Water inlet temperature
TH220	Water outlet temperature
TH221	Water inlet temperature
TH222	Water outlet temperature
TH223	Water inlet temperature
TH224	Water outlet temperature
TH225	Water inlet temperature
TH226	Water outlet temperature
TH227	Water inlet temperature
TH228	Water outlet temperature
TH229	Water inlet temperature
TH230	Water outlet temperature
TH231	Water inlet temperature
TH232	Water outlet temperature
TH233	Water inlet temperature
TH234	Water outlet temperature
TH235	Water inlet temperature
TH236	Water outlet temperature
TH237	Water inlet temperature
TH238	Water outlet temperature
TH239	Water inlet temperature
TH240	Water outlet temperature
TH241	Water inlet temperature
TH242	Water outlet temperature
TH243	Water inlet temperature
TH244	Water outlet temperature
TH245	Water inlet temperature
TH246	Water outlet temperature
TH247	Water inlet temperature
TH248	Water outlet temperature
TH249	Water inlet temperature
TH250	Water outlet temperature
TH251	Water inlet temperature
TH252	Water outlet temperature
TH253	Water inlet temperature
TH254	Water outlet temperature
TH255	Water inlet temperature
TH256	Water outlet temperature
TH257	Water inlet temperature
TH258	Water outlet temperature
TH259	Water inlet temperature
TH260	Water outlet temperature
TH261	Water inlet temperature
TH262	Water outlet temperature
TH263	Water inlet temperature
TH264	Water outlet temperature
TH265	Water inlet temperature
TH266	Water outlet temperature
TH267	Water inlet temperature
TH268	Water outlet temperature
TH269	Water inlet temperature
TH270	Water outlet temperature
TH271	Water inlet temperature
TH272	Water outlet temperature
TH273	Water inlet temperature
TH274	Water outlet temperature
TH275	Water inlet temperature
TH276	Water outlet temperature
TH277	Water inlet temperature
TH278	Water outlet temperature
TH279	Water inlet temperature
TH280	Water outlet temperature
TH281	Water inlet temperature
TH282	Water outlet temperature
TH283	Water inlet temperature
TH284	Water outlet temperature
TH285	Water inlet temperature
TH286	Water outlet temperature
TH287	Water inlet temperature
TH288	Water outlet temperature
TH289	Water inlet temperature
TH290	Water outlet temperature
TH291	Water inlet temperature
TH292	Water outlet temperature
TH293	Water inlet temperature
TH294	Water outlet temperature
TH295	Water inlet temperature
TH296	Water outlet temperature
TH297	Water inlet temperature
TH298	Water outlet temperature
TH299	Water inlet temperature
TH300	Water outlet temperature
TH301	Water inlet temperature
TH302	Water outlet temperature
TH303	Water inlet temperature
TH304	Water outlet temperature
TH305	Water inlet temperature
TH306	Water outlet temperature
TH307	Water inlet temperature
TH308	Water outlet temperature
TH309	Water inlet temperature
TH310	Water outlet temperature
TH311	Water inlet temperature
TH312	Water outlet temperature
TH313	Water inlet temperature
TH314	Water outlet temperature
TH315	Water inlet temperature
TH316	Water outlet temperature
TH317	Water inlet temperature
TH318	Water outlet temperature
TH319	Water inlet temperature
TH320	Water outlet temperature
TH321	Water inlet temperature
TH322	Water outlet temperature
TH323	Water inlet temperature
TH324	Water outlet temperature
TH325	Water inlet temperature
TH326	Water outlet temperature
TH327	Water inlet temperature
TH328	Water outlet temperature
TH329	Water inlet temperature
TH330	Water outlet temperature
TH331	Water inlet temperature
TH332	Water outlet temperature
TH333	Water inlet temperature
TH334	Water outlet temperature
TH335	Water inlet temperature
TH336	Water outlet temperature
TH337	Water inlet temperature
TH338	Water outlet temperature
TH339	Water inlet temperature
TH340	Water outlet temperature
TH341	Water inlet temperature
TH342	Water outlet temperature
TH343	Water inlet temperature
TH344	Water outlet temperature
TH345	Water inlet temperature
TH346	Water outlet temperature
TH347	Water inlet temperature
TH348	Water outlet temperature
TH349	Water inlet temperature
TH350	Water outlet temperature
TH351	Water inlet temperature
TH352	Water outlet temperature
TH353	Water inlet temperature
TH354	Water outlet temperature
TH355	Water inlet temperature
TH356	Water outlet temperature
TH357	Water inlet temperature
TH358	Water outlet temperature
TH359	Water inlet temperature
TH360	Water outlet temperature
TH361	Water inlet temperature
TH362	Water outlet temperature
TH363	Water inlet temperature
TH364	Water outlet temperature
TH365	Water inlet temperature
TH366	Water outlet temperature
TH367	Water inlet temperature
TH368	Water outlet temperature
TH369	Water inlet temperature
TH370	Water outlet temperature
TH371	Water inlet temperature
TH372	Water outlet temperature
TH373	Water inlet temperature
TH374	Water outlet temperature
TH375	Water inlet temperature
TH376	Water outlet temperature
TH377	Water inlet temperature
TH378	Water outlet temperature
TH379	Water inlet temperature
TH380	Water outlet temperature
TH381	Water inlet temperature
TH382	Water outlet temperature
TH383	Water inlet temperature
TH384	Water outlet temperature
TH385	Water inlet temperature
TH386	Water outlet temperature
TH387	Water inlet temperature
TH388	Water outlet temperature
TH389	Water inlet temperature
TH390	Water outlet temperature
TH391	Water inlet temperature
TH392	Water outlet temperature
TH393	Water inlet temperature
TH394	Water outlet temperature
TH395	Water inlet temperature
TH396	Water outlet temperature
TH397	Water inlet temperature
TH398	Water outlet temperature
TH399	Water inlet temperature
TH400	Water outlet temperature
TH401	Water inlet temperature
TH402	Water outlet temperature
TH403	Water inlet temperature
TH404	Water outlet temperature
TH405	Water inlet temperature
TH406	Water outlet temperature
TH407	Water inlet temperature
TH408	Water outlet temperature
TH409	Water inlet temperature
TH410	Water outlet temperature
TH411	Water inlet temperature
TH412	

(4) PQHY-P72, 96, 120, 144, 168, 192, 216, 240YLMU-A1
PQRY-P72, 96, 120, 144, 168, 192, 216, 240YLMU-A1

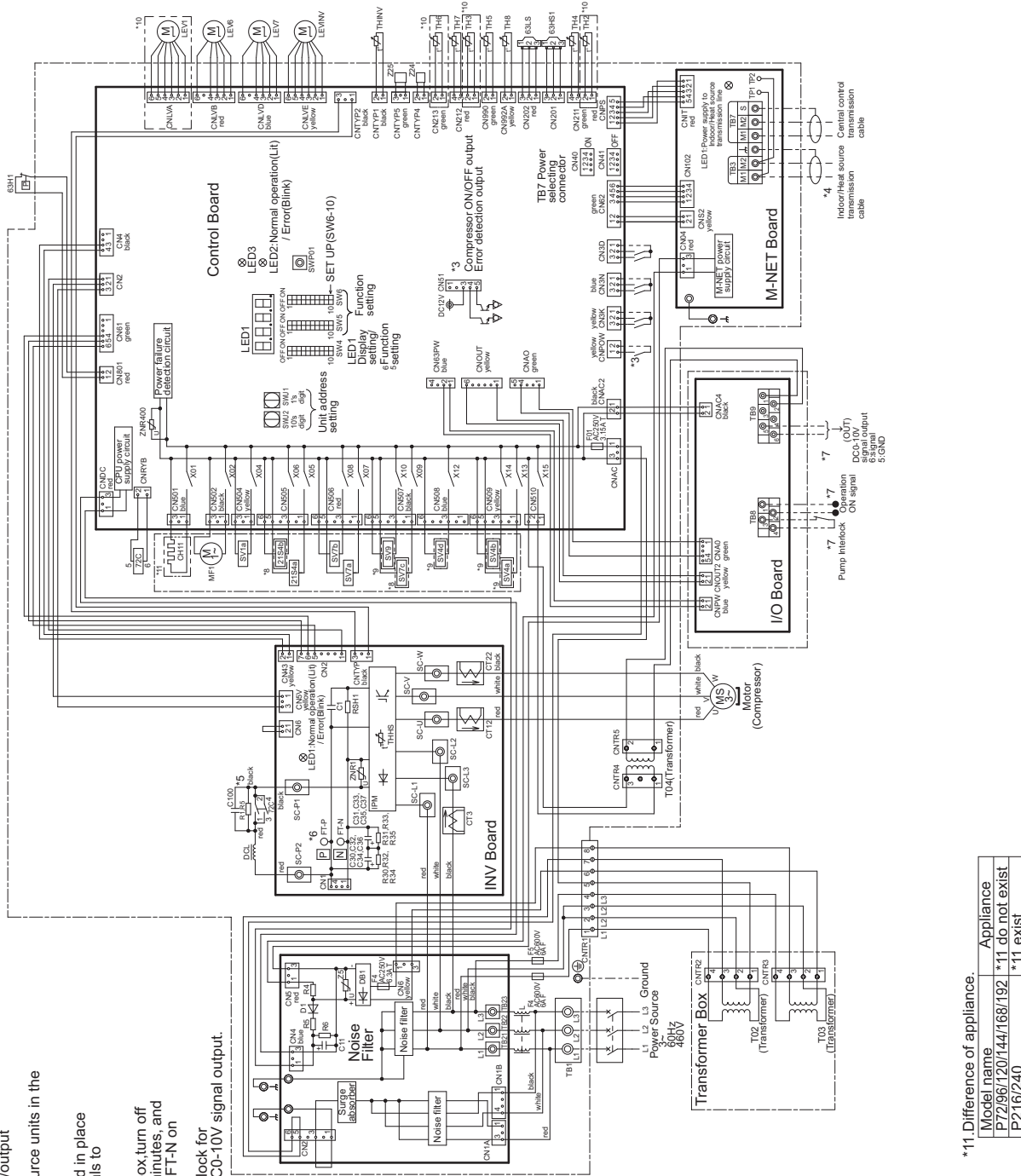

- *1. Single-dotted lines indicate wiring not supplied with the unit.
- *2. Dot-dash lines indicate the control box boundaries.
- *3. Refer to the Data book for connecting input/output signal connectors.
- *4. Daisy-chain terminals (TB3) on the heat source units in the same refrigerant system together.
- *5. Faston terminals have a locking function. Make sure the terminals are securely locked in place after insertion. Press the tab on the terminals to removed them.
- *6. Control box houses high-voltage parts. Before inspecting the inside of the control box turn off the power, keep the unit off for at least 10 minutes, and confirm that the voltage between FT-P and FT-N on INV Board has dropped to DC20V or less.
- *7. Refer to the Data book for wiring terminal block for Pump Interlock, Operation ON signal and DC0-10V signal output.
- *8. Difference of appliance.

Model name	Appliance
P72/96/120	*8 do not exist
P144/168/192/216/240	*8 exist

Model name	Appliance
PQHY	*9 do not exist
PQRY	*9 exist

Model name	Appliance
PQHY	*10 exist
PQRY	*10 do not exist

<Symbol explanation>

Symbol	Explanation
21SA4	4-way valve
21S4B	Cooling/Heating switching
63H1	Heat exchanger capacity control
63HS1	Pressure
63HS1	High pressure protection for the heat source unit
63HS1	Pressure
63HS1	High pressure
63HS1	Low pressure
63HS1	Capacitor (main circuit)
C30-C37	Capacitor (main circuit)
CH11	Crankcase heater (for heating the compressor)
CH12,22,3	Current sensor (AC)
L	DC reactor
L	Choke coil (for high frequency noise reduction)
LEV1	Linear expansion valve
LEV6	HFC bypass Controls refrigerant
LEV7	Heat exchanger capacity control
LEV8	Heat exchanger capacity control
LEV9	Heat exchanger capacity control
MF1	Heat exchanger for inverter
RF1	Heat exchanger (Radiator panel)
RL5	Resistor
RSH1	For inrush current prevention
SV1a	Solenoid valve
SV4a,b,d	For opening/closing the bypass circuit under the O/S
SV7a,b,c	Heat exchanger capacity control
SV9	For opening/closing the bypass circuit
TB1	Power supply
TB3	Indoor/Heat source transmission cable
TB7	Central control transmission
TB8	Operation ON signal,
TB9	Pump Interlock
TB9	Power input and signal output for variable water flow valve
TH2	Subcool bypass outlet temperature
TH3	Pipe temperature
TH4	Discharge pipe temperature
TH5	Suction pipe temperature
TH6	Subcool bypass refrigerant temperature
TH7	Water inlet temperature
TH8	Water outlet temperature
THINV	Outlet temp. detect of heat exchanger for inverter
THHS	IPM temperature
ZZ4,Z5	Function setting connector

*11. Difference of appliance.
 Model name Appliance
 P72/96/120/144/168/192 *11 do not exist
 P216/240 *11 exist

[2] Electrical Wiring Diagram of the BC Controller

(1) CMB-P104NU-G1 model

(Symbol explanation)

Symbol	Name
TR	Transformer
TH11,12,15,16	Thermistor sensor
LEV1,3	Expansion valve
PS1,3	Pressure sensor
CONT.B	Circuit board
TB01	Terminal block (for power source)
TB02	Terminal block (for Transmission)
SV1~4A,B,C	Solenoid valve
SVM1	Solenoid valve
T1~4	Terminal
F01	Fuse AC250V 6.3A F

Note: 1. TB02 is transmission terminal block. Never connect power line to it.
 2. The initial set values of switch on CONT.B are as follows.
 SW1:0
 SW2:0

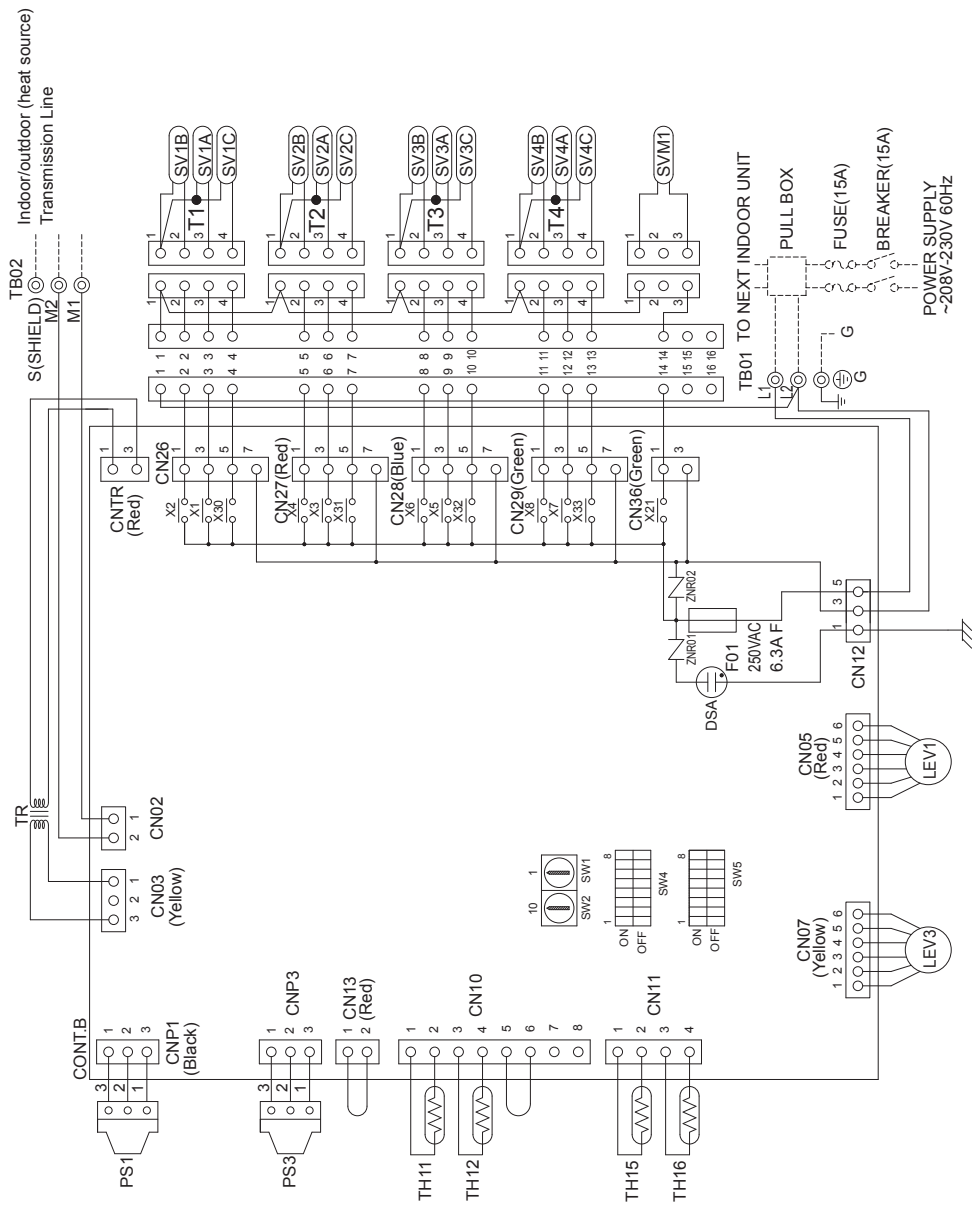

(2) CMB-P105,106NU-G1 models

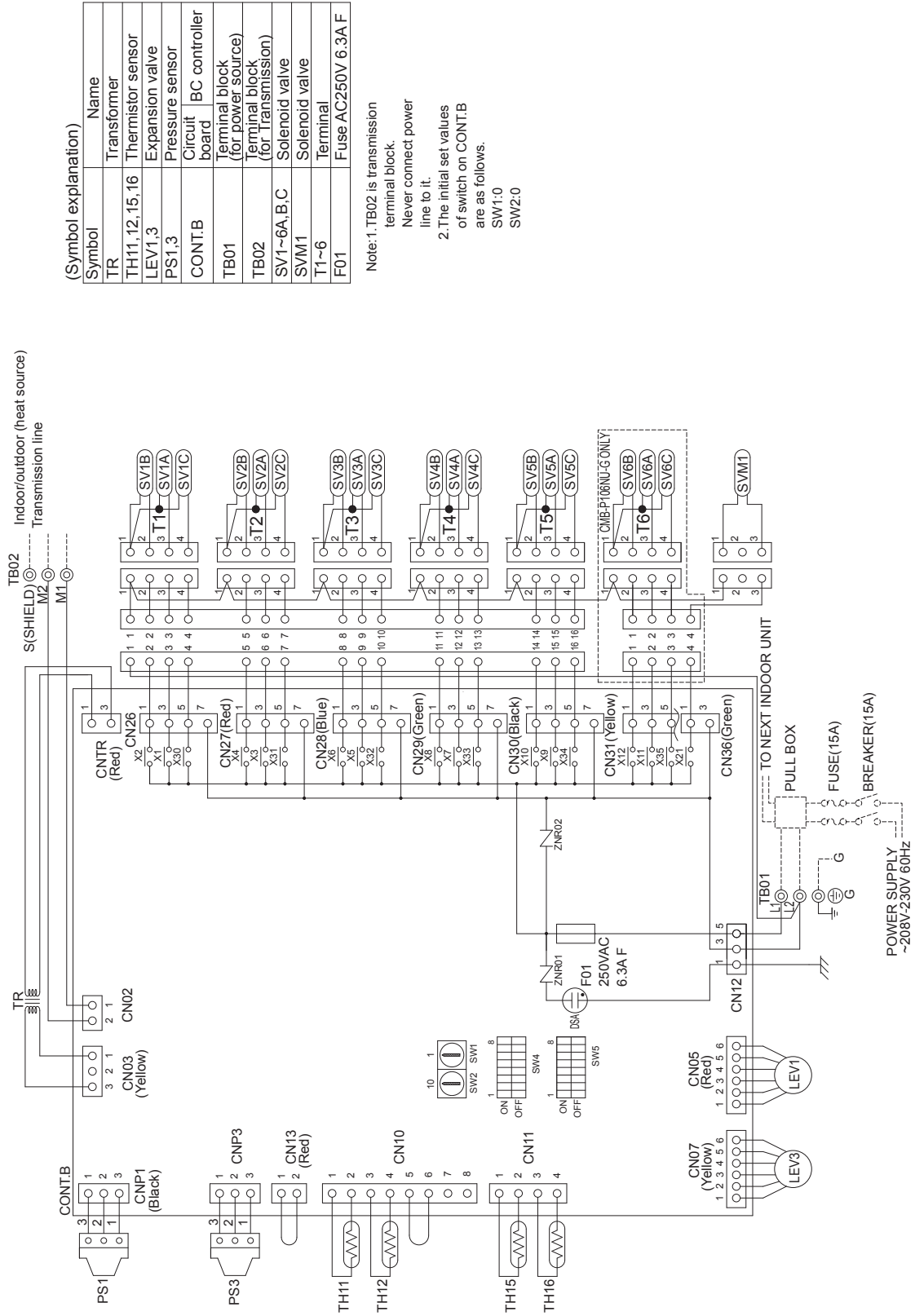

(Symbol explanation)

Symbol	Name
TR	Transformer
TH11, 12, 15, 16	Thermistor sensor
LEV1, 3	Expansion valve
PS1, 3	Pressure sensor
CONT.B	Circuit board
TB01	Terminal block (for power source)
TB02	Terminal block (for Transmission)
SV1~6A, B, C	Solenoid valve
SVM1	Solenoid valve
T1~6	Terminal
F01	Fuse AC250V 6.3A F

Note: 1. TB02 is transmission terminal block.
 Never connect power line to it.
 2. The initial set values of switch on CONT.B are as follows.
 SW1:0
 SW2:0

(3) CMB-P108,1010NU-G1 models

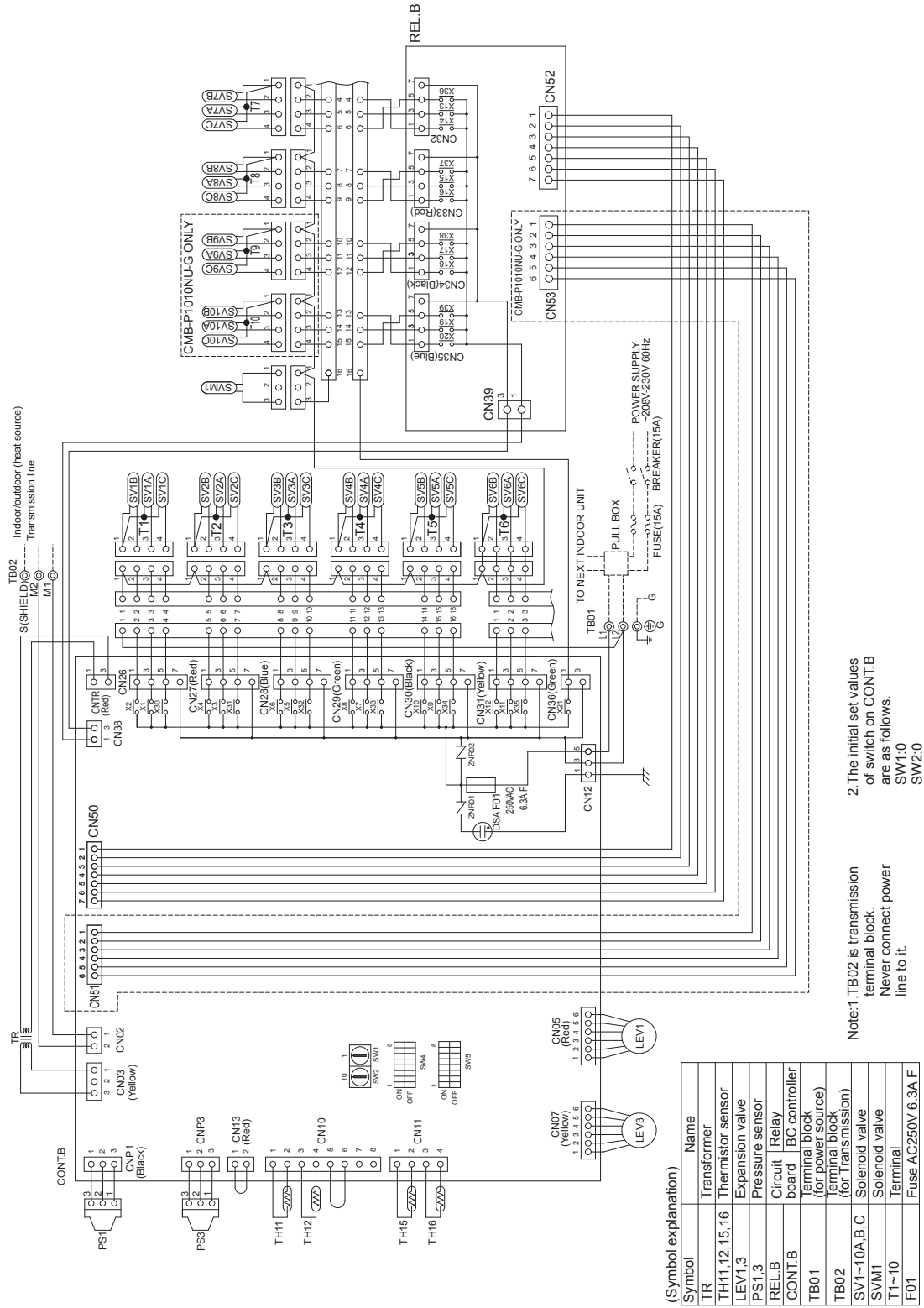

(4) CMB-P1013,1016NU-G1 models

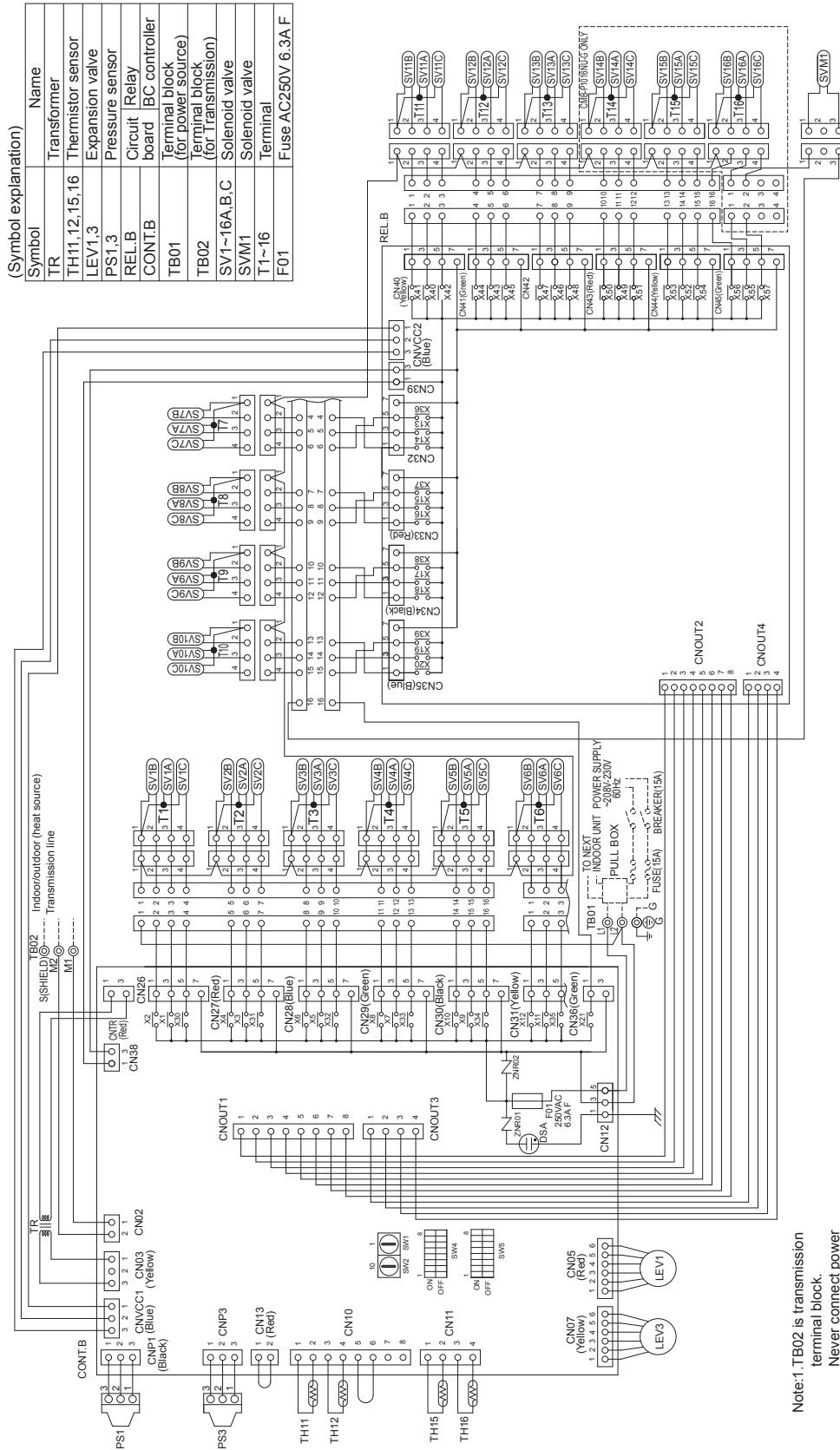

(5) CMB-P108,1010NU-GA1 models

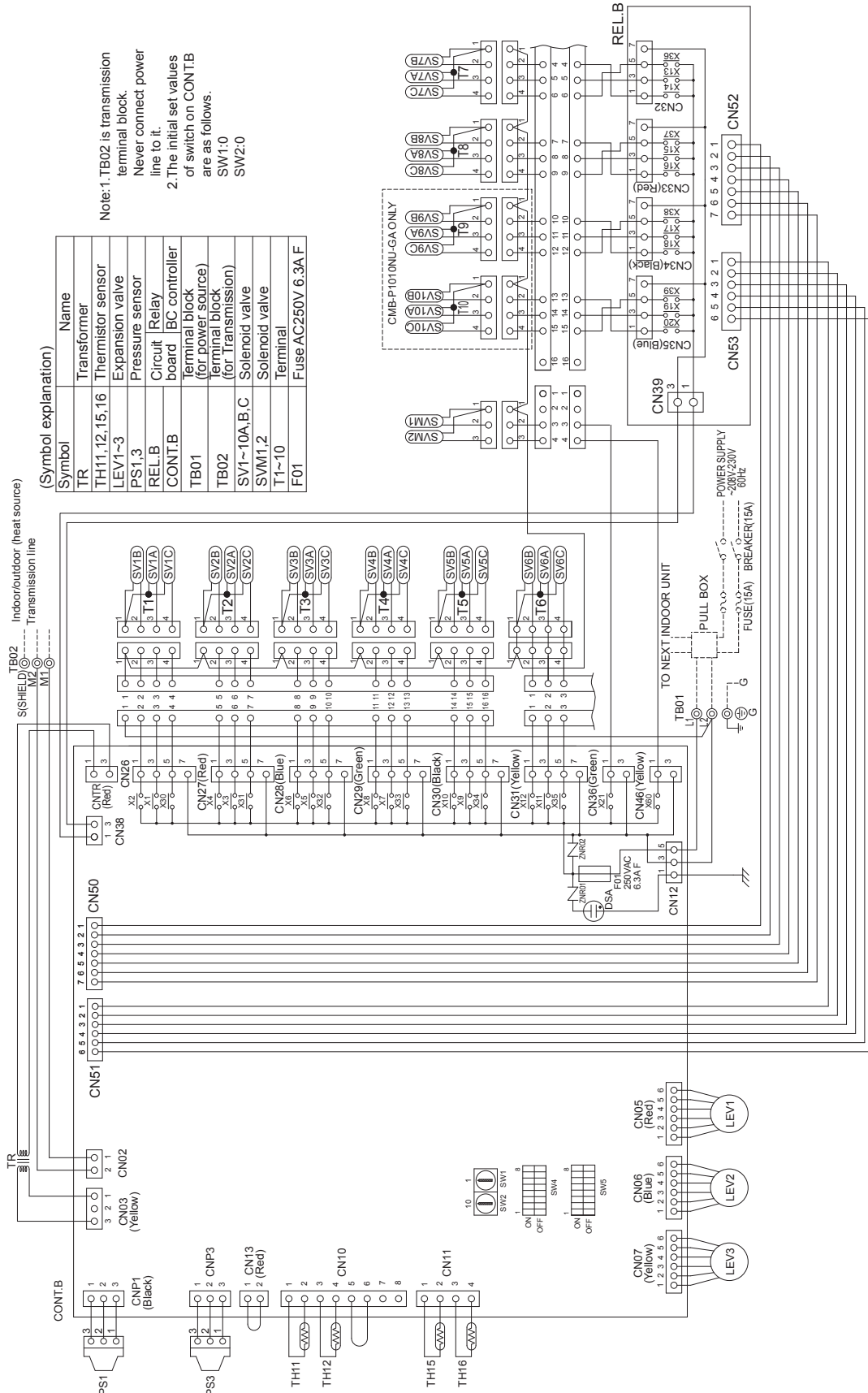

(6) CMB-P1013,1016NU-GA1 models

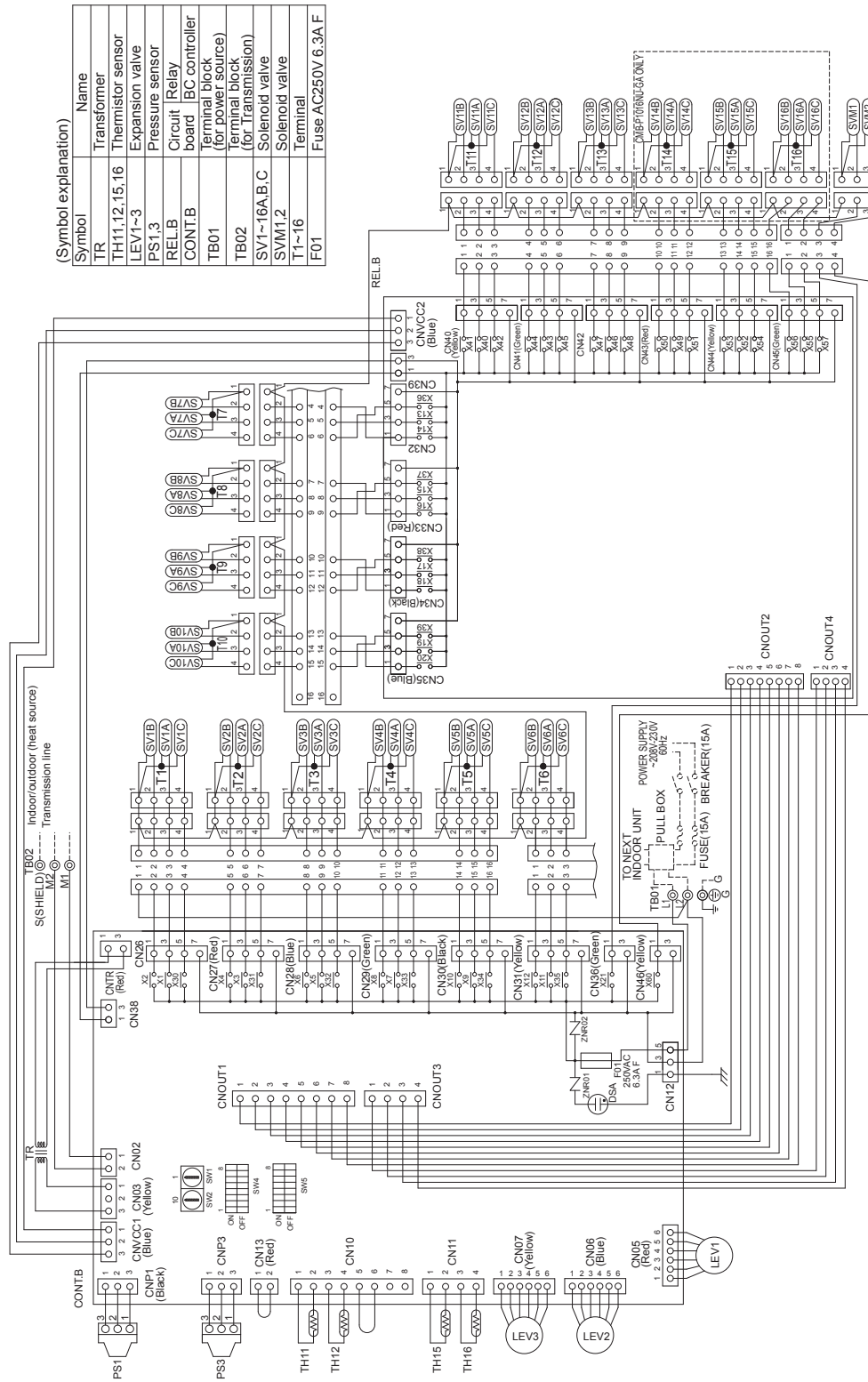

Note:1. TB02 is transmission terminal block. Never connect power line to it.
 2. The initial set values of switch on CONT.B are as follows.
 SW1:0
 SW2:0

(7) CMB-P104NU-GB1 model

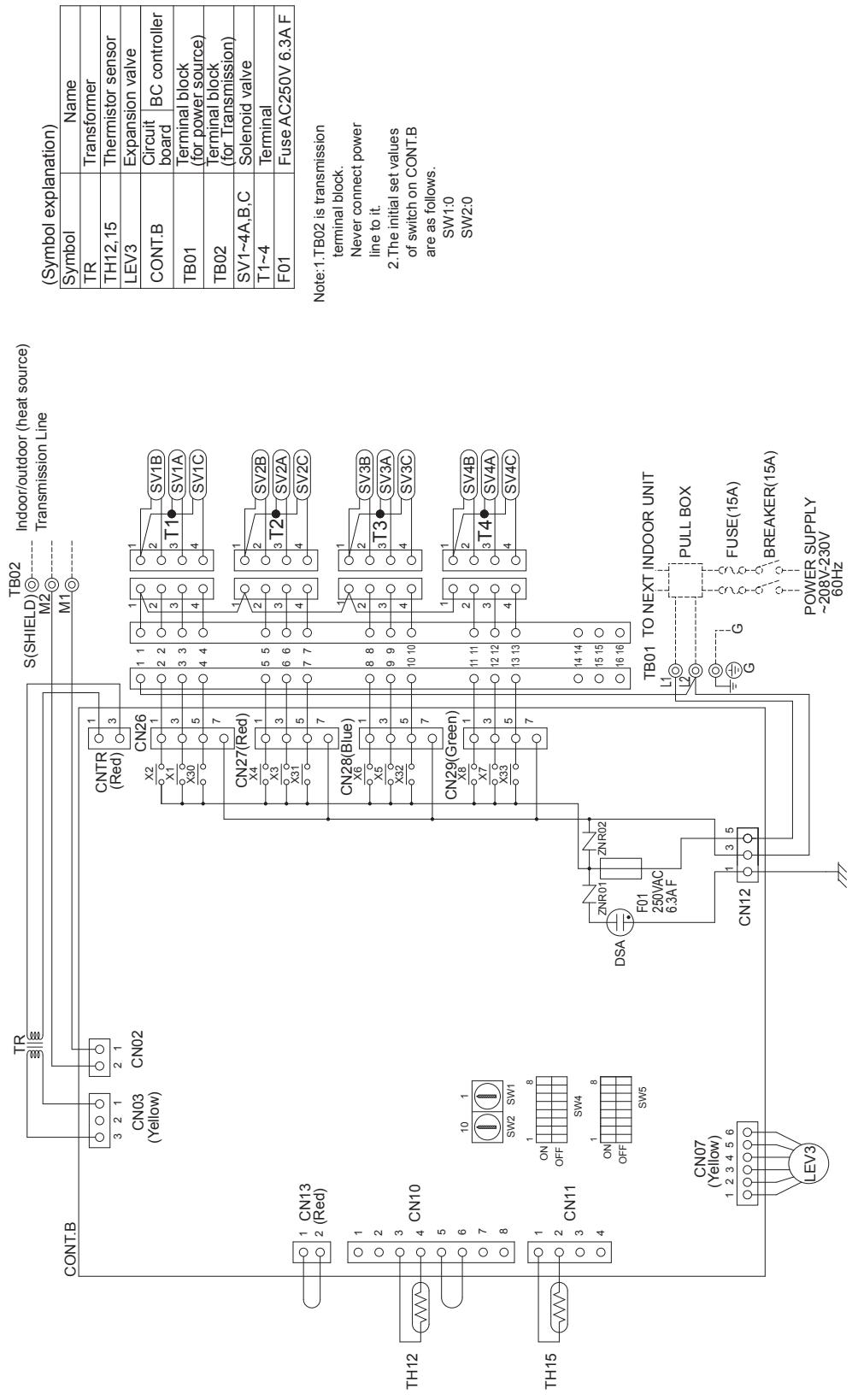

(Symbol explanation)

Symbol	Name
TR	Transformer
TH12, 15	Thermistor sensor
LEV3	Expansion valve
CONT.B	Circuit board
TB01	Terminal block (for power source)
TB02	Terminal block (for Transmission)
SV1~4A, B, C	Solenoid valve
T1~4	Terminal
F01	Fuse AC250V 6.3A F

Note: 1. TB02 is transmission terminal block.
 Never connect power line to it.
 2. The initial set values of switch on CONT.B are as follows.
 SW1:0
 SW2:0

(8) CMB-P108NU-GB1 model

(Symbol explanation)

Symbol	Name
TR	Transformer
TH1,2,15	Thermistor sensor
LEV3	Expansion valve
RELB	Circuit Relay
CONT.B	BC controller board
TB01	Terminal block (for power source)
TB02	Terminal block (for Transmission)
SV1~8A,B,C	Solenoid valve
T1~8	Terminal
F01	Fuse AC250V 6.3AF

Note: 1. TB02 is transmission terminal block.
 Never connect power line to it.
 2. The initial set values of switch on CONT.B are as follows.
 SW1:0
 SW2:0

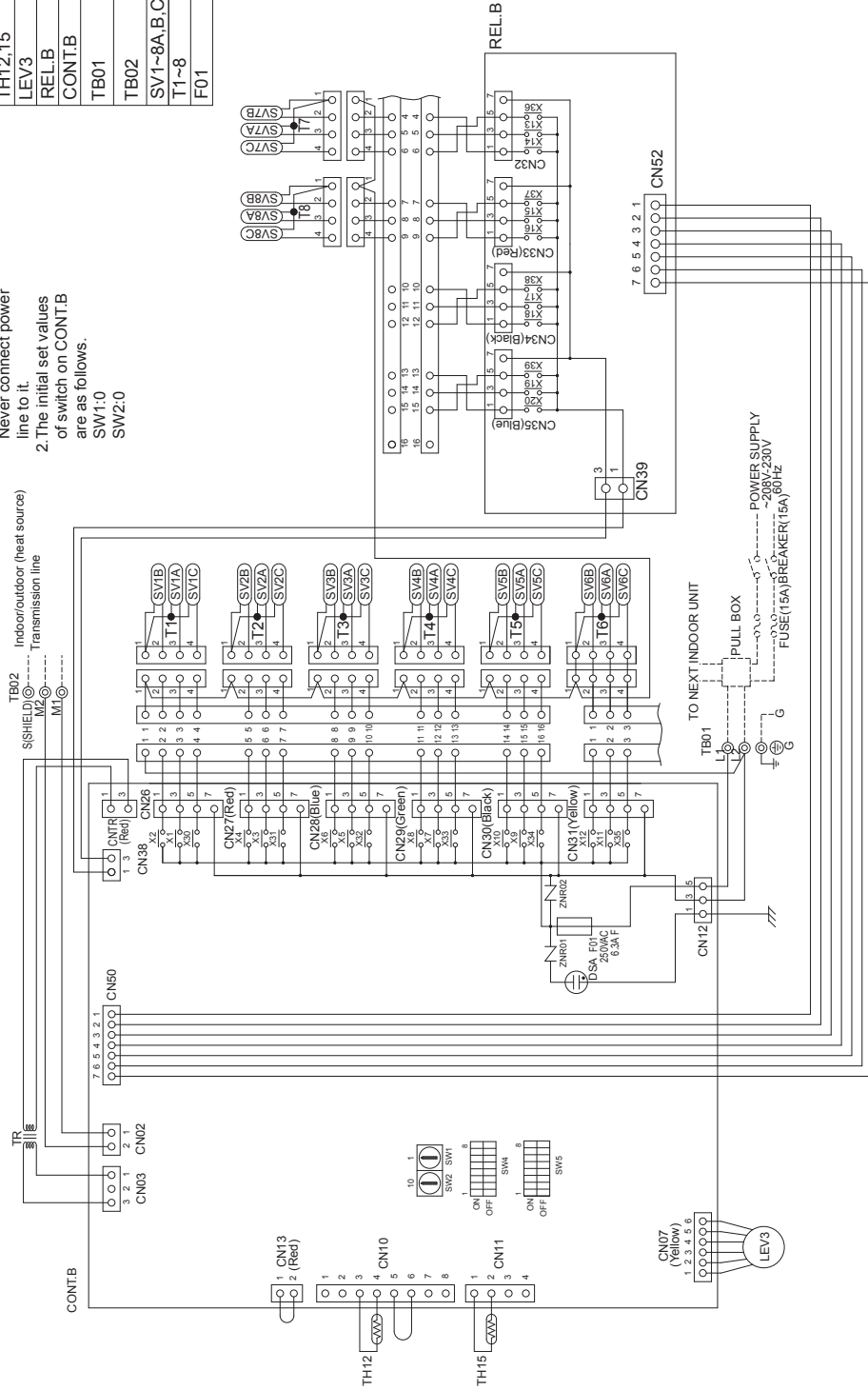

(9) CMB-P1016NU-HA1 model

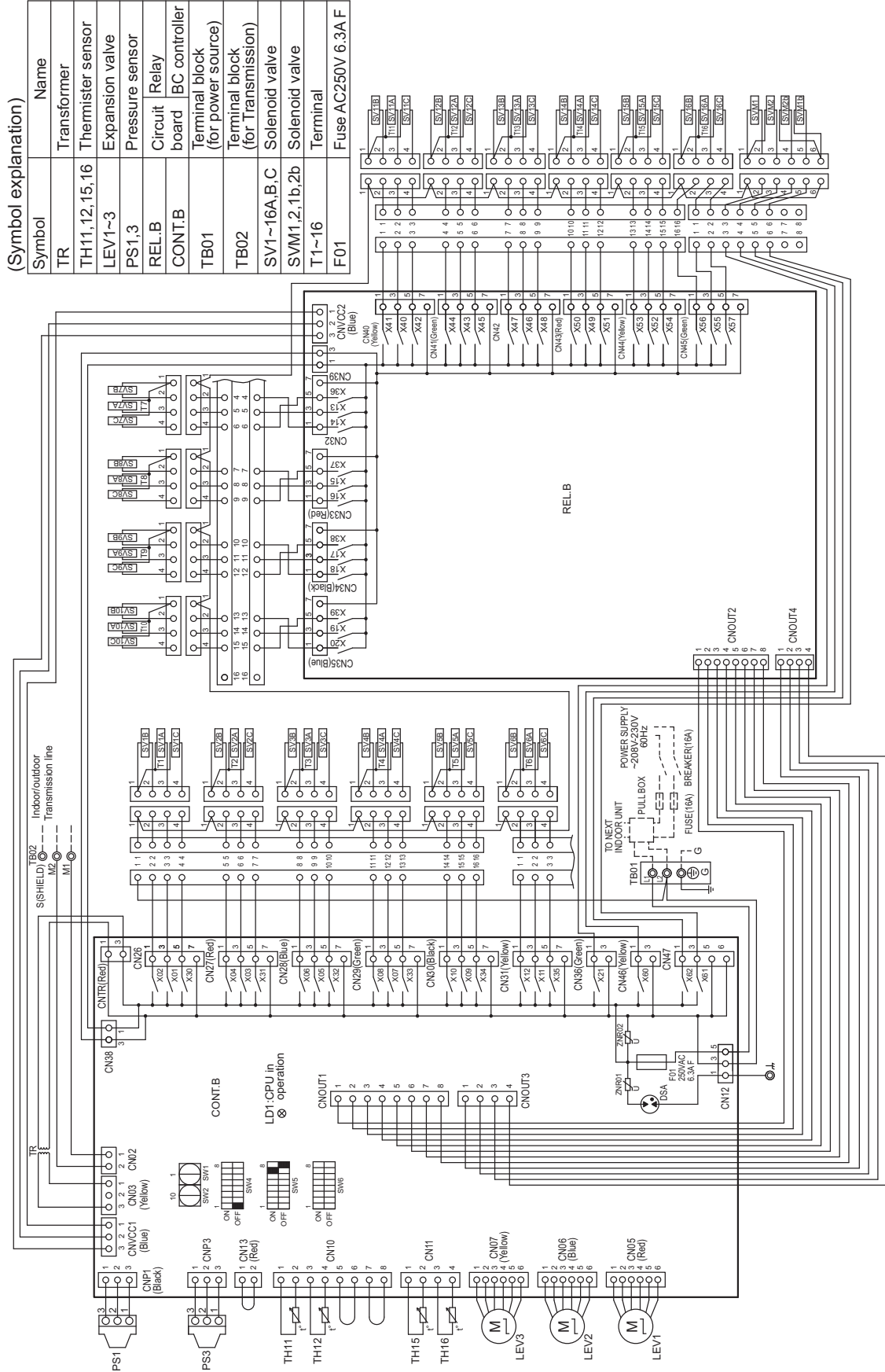

(10) CMB-P1016NU-HB1 model

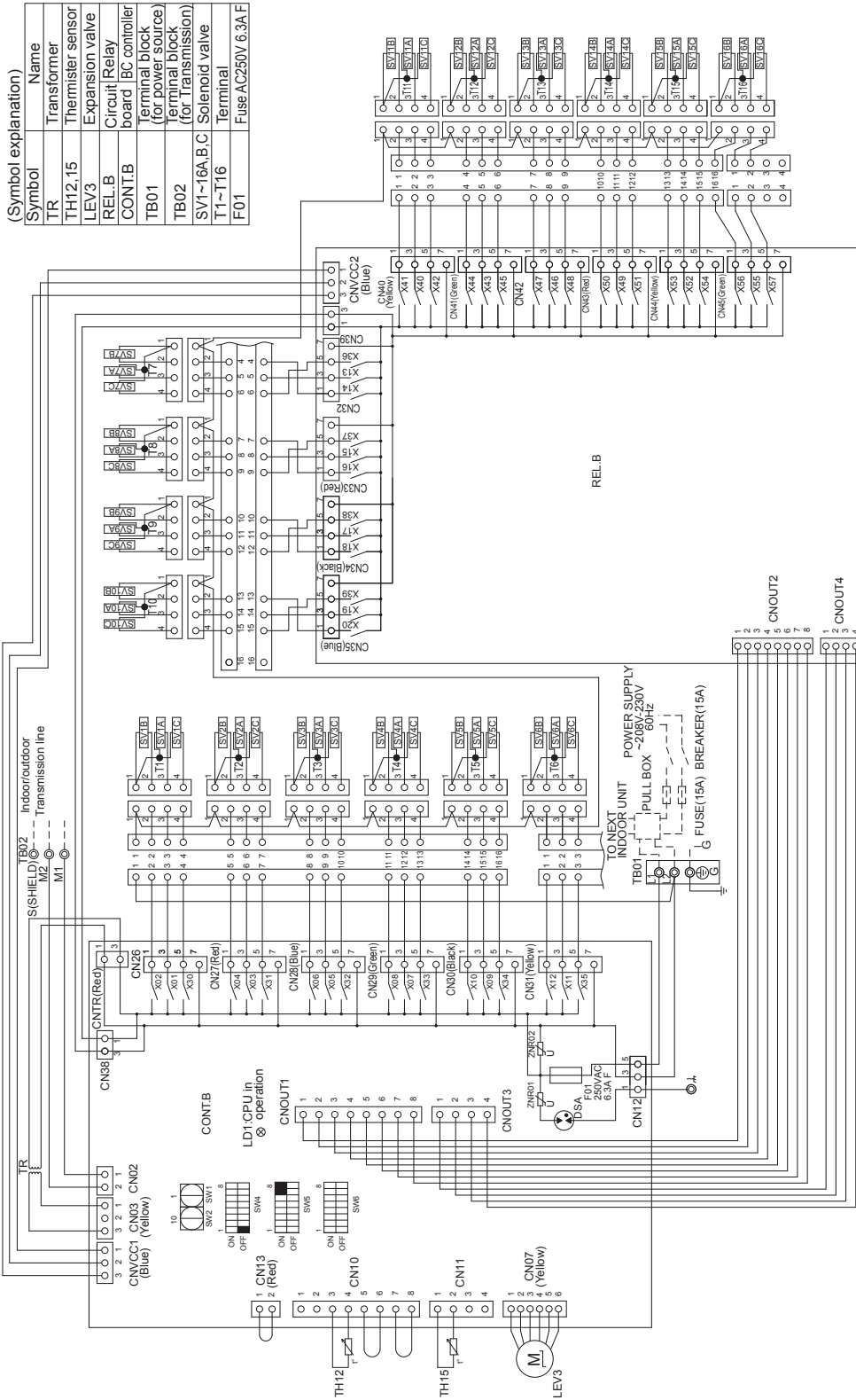

Symbol	Name
TR	Transformer
TH12,15	Thermister sensor
LEV3	Expansion valve
RELB	Circuit Relay
CONTB	board IC controller
TB01	Terminal block (for power source)
TB02	Terminal block (for Transmission)
SV1~16A,B,C	Solenoid valve
T1~T16	Terminal
F01	Fuse AC250V 6.3A F

(Symbol explanation)

2. The initial set values of switch on CONT.B are as follows.
 SW1:0
 SW2:0

Note:1. TB02 is transmission terminal block. Never connect power line to it.

[3] Electrical Wiring Diagram of Transmission Booster

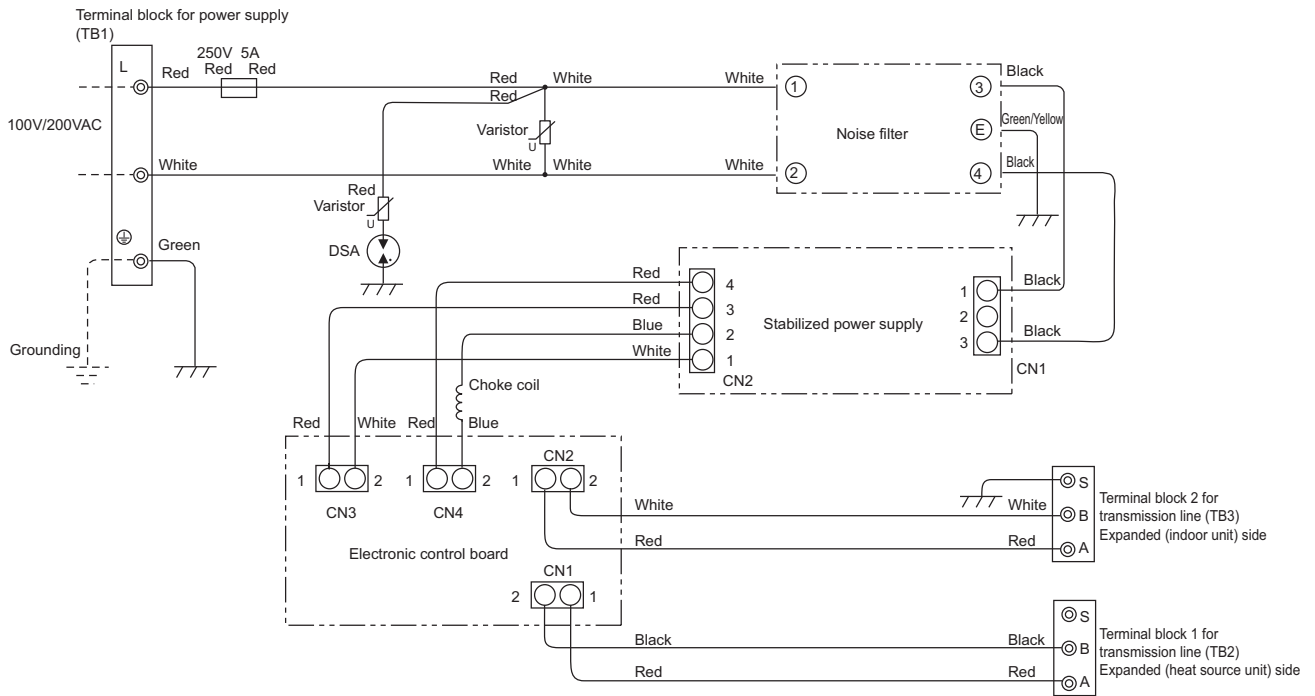

VI Refrigerant Circuit

[1] Refrigerant Circuit Diagram	141
[2] Principal Parts and Functions	147



[1] Refrigerant Circuit Diagram

1. Heat source unit

(1) PQHY-P72, P96, P120 models

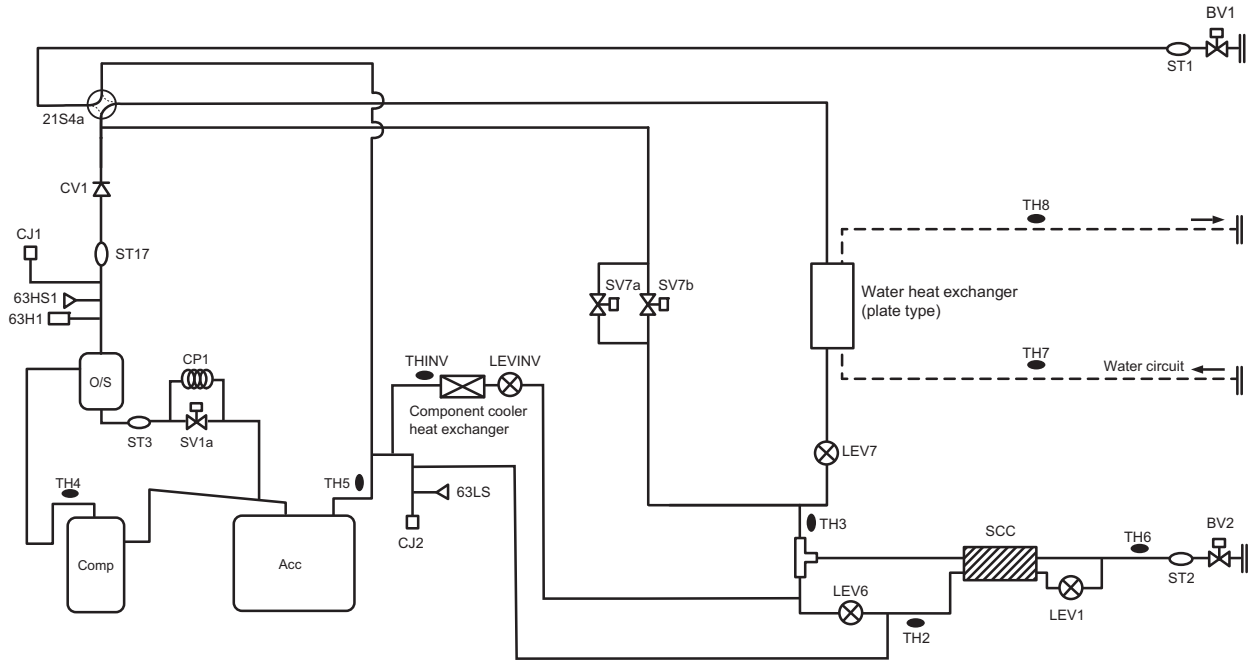

(2) PQRY-P72, P96, P120 models

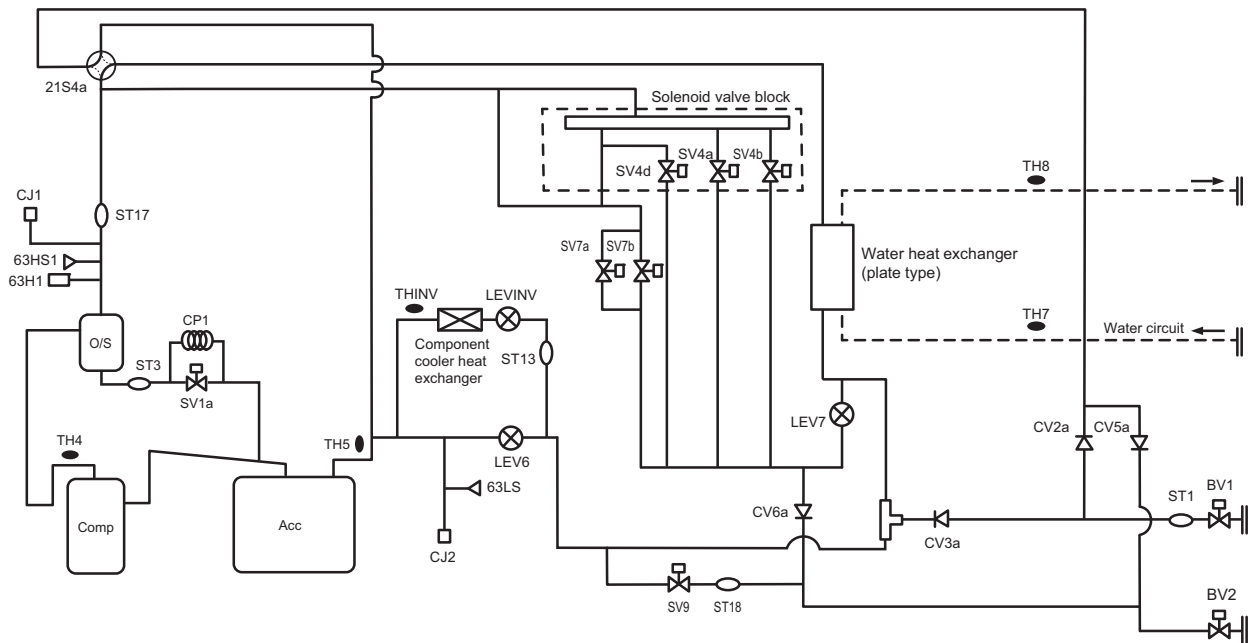

(3) PQHY-P144, P168, P192 models

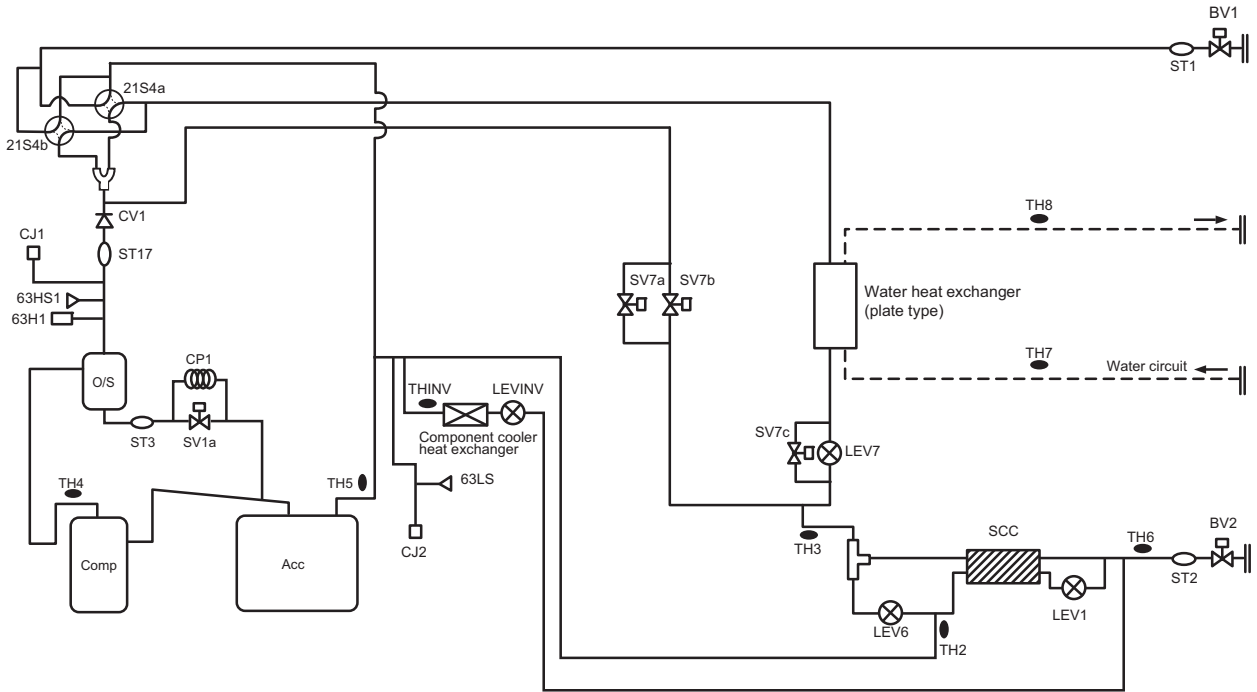

(4) PQRY-P144, P168, P192 models

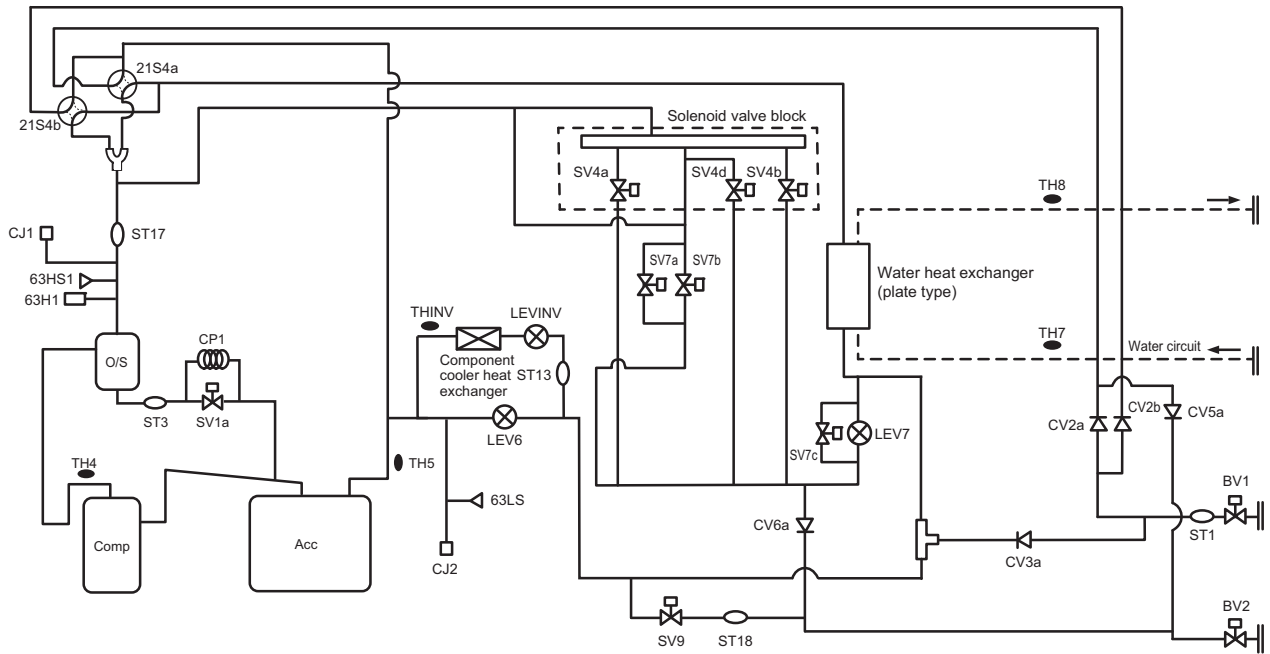

(5) PQHY-P216, P240 models

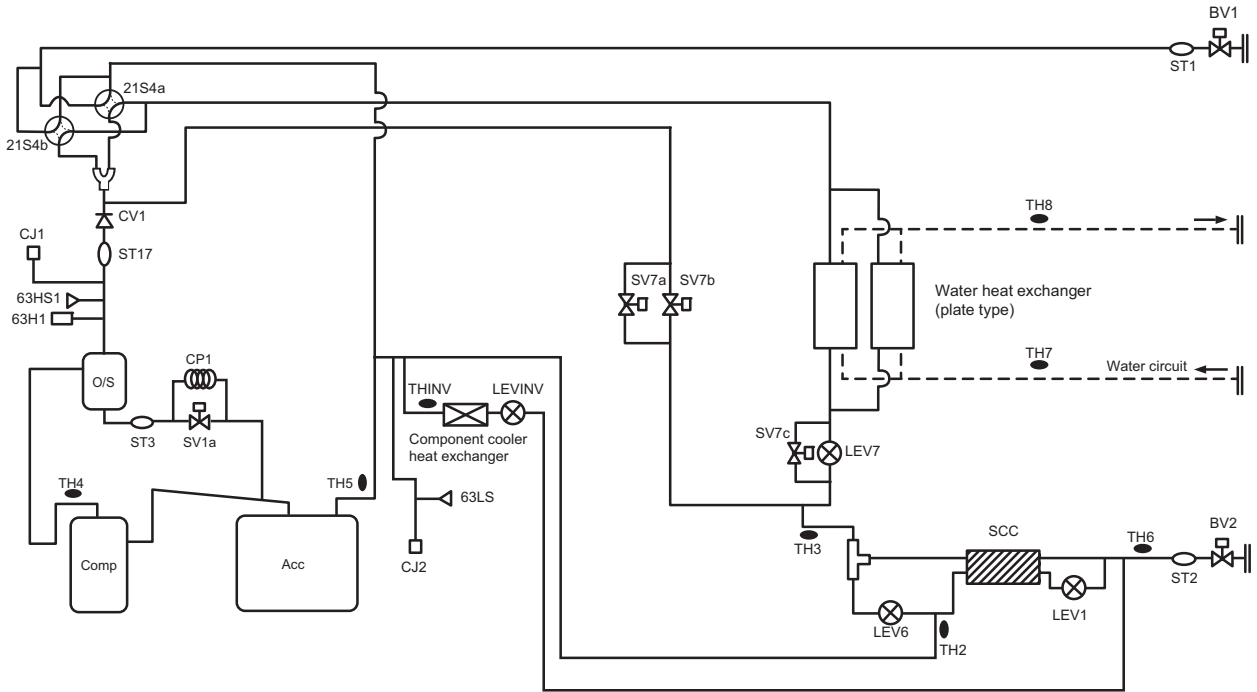

(6) PQRy-P216, P240 models

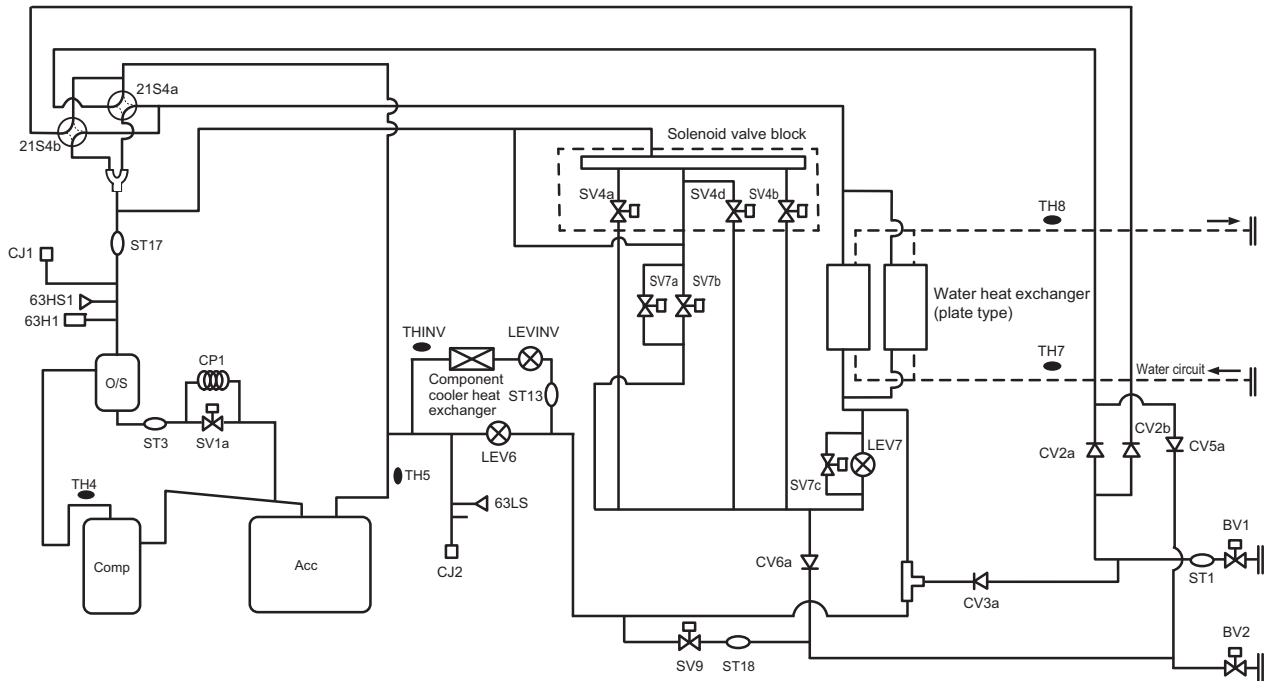

2. BC controller
(1) CMB-P104 - P1016NU-G1

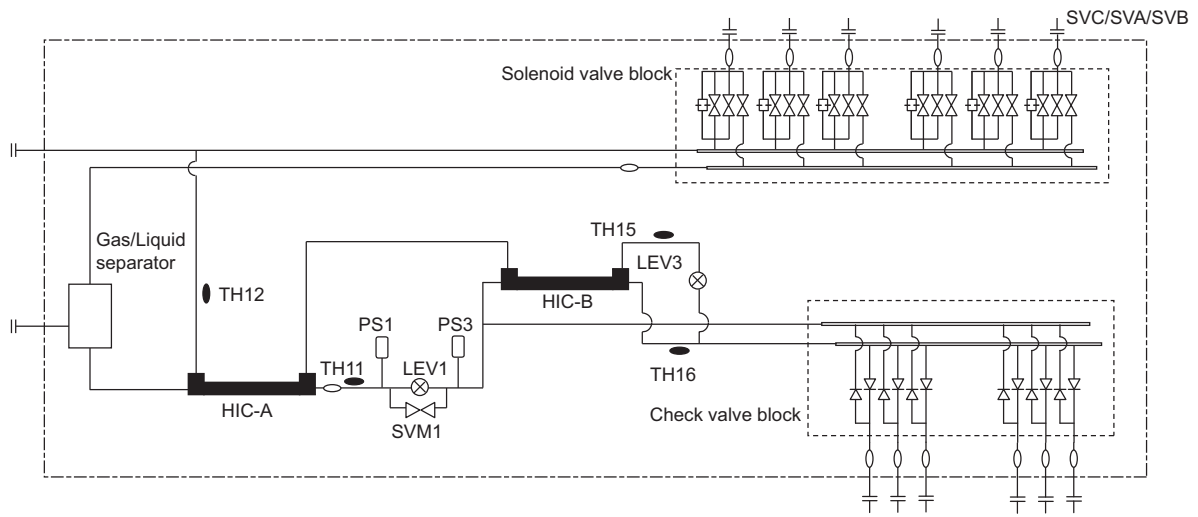

(2) CMB-P108, P1010, P1013, P1016NU-GA1 (main)

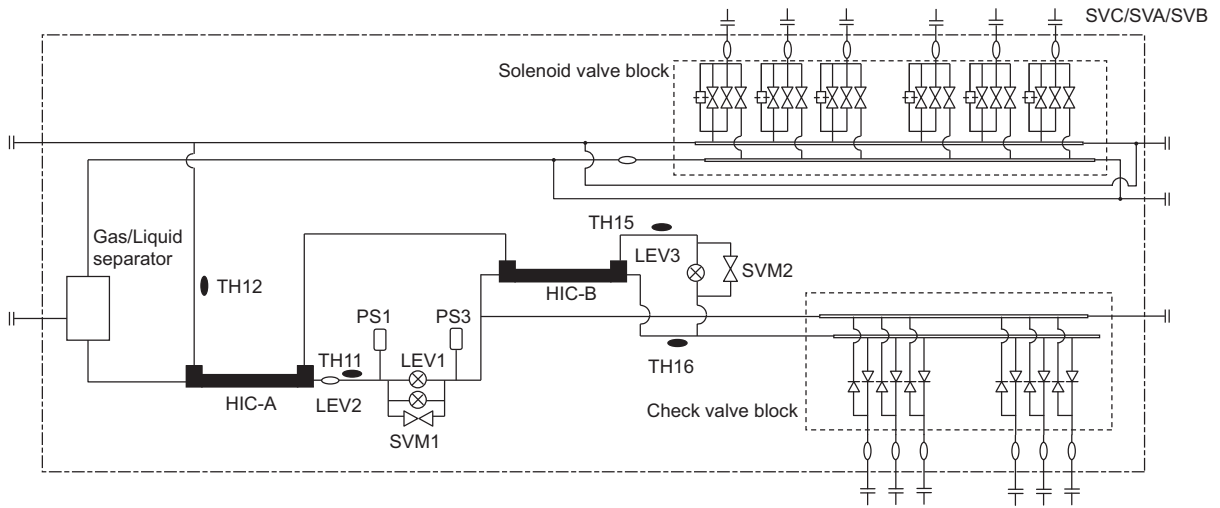

(3) CMB-P104, P108NU-GB1 (sub)

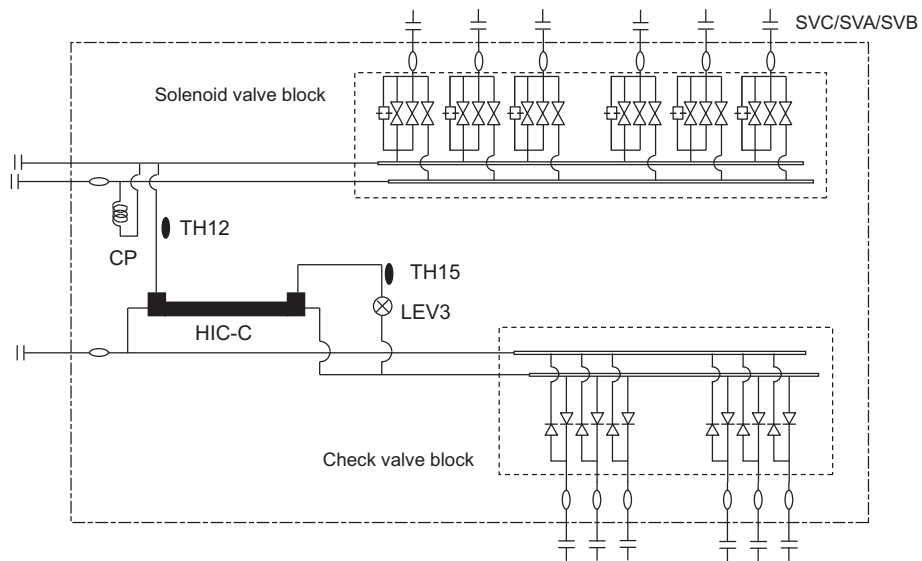

(4) CMB-P108, P1010, P1016NU-HA1 (main)

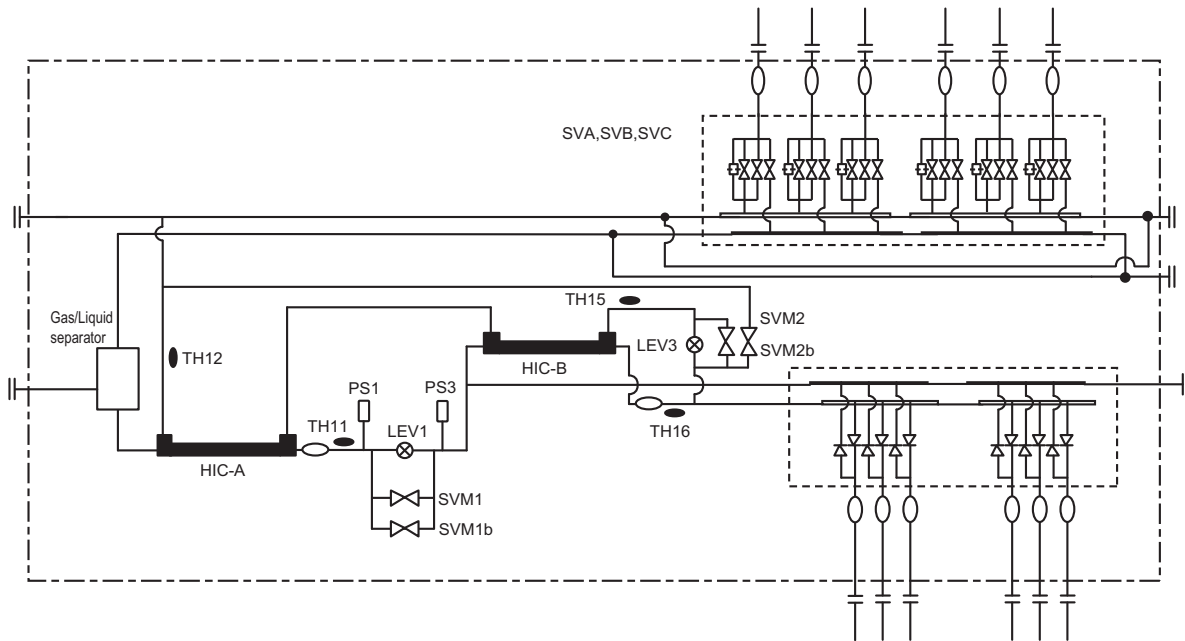

(5) CMB-P1016NU-HB1 (sub)

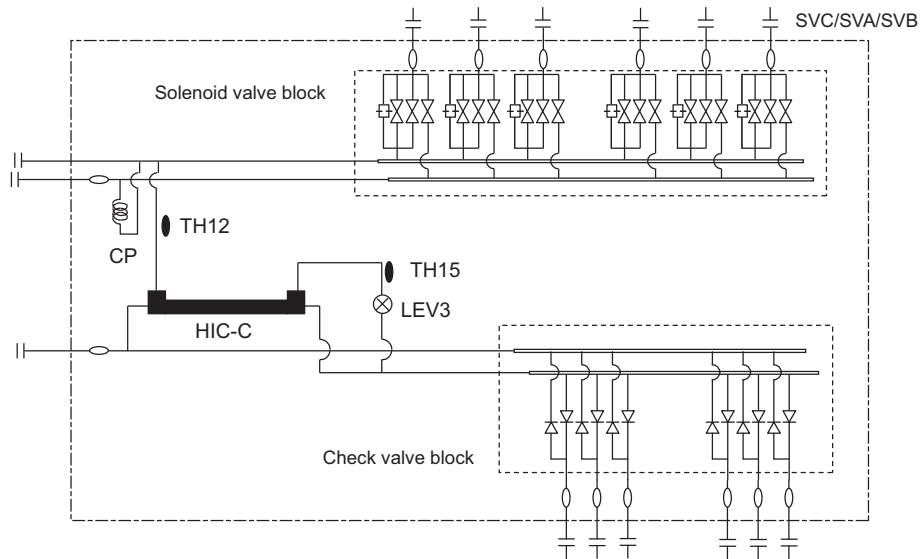

[2] Principal Parts and Functions

1. Heat source unit

Part name	Symbols (functions)	Notes	Usage	Specifications	Check method
Com-pressor	MC1 (Comp1)		Adjusts the amount of circulating refrigerant by adjusting the operating frequency based on the operating pressure data	Low-pressure shell scroll compressor Wirewound resistance 20°C[68°F] : 0.268ohm(THMU) 0.981ohm(YHMU)	
High pressure sensor	63HS1		1) Detects high pressure 2) Regulates frequency and provides high-pressure protection	<p>63HS1 Pressure 0-4.15 MPa [601psi] Vout 0.5-3.5V 0.071V/0.098 MPa [14psi] Pressure [MPa] =1.38 x Vout [V]-0.69 Pressure [psi] =(1.38 x Vout [V] - 0.69) x 145 1 GND (Black) 2 Vout (White) 3 Vcc (DC5V) (Red)</p>	
Low pressure sensor	63LS		1) Detects low pressure 2) Provides low-pressure protection	<p>63LS Pressure 0-1.7 MPa [247psi] Vout 0.5-3.5V 0.173V/0.098 MPa [14psi] Pressure [MPa] =0.566 x Vout [V] - 0.283 Pressure [psi] =(0.566 x Vout [V] - 0.283) x 145 1 GND (Black) 2 Vout (White) 3 Vcc (DC5V) (Red)</p>	
Pressure switch	63H1		1) Detects high pressure 2) Provides high-pressure protection	4.15MPa[601psi] OFF setting	
Thermistor	TH4 (Discharge)		1) Detects discharge air temperature 2) Provides high-pressure protection	<p>Degrees Celsius</p> $R_{120} = 7.465k\Omega$ $R_{25/120} = 4057$ $R_t = 7.465 \exp\{4057(\frac{1}{273+t} - \frac{1}{393})\}$	Resistance check
			<p>0°C[32°F] :698kohm 10°C[50°F] :413kohm 20°C[68°F] :250kohm 30°C[86°F] :160kohm 40°C[104°F] :104kohm 50°C[122°F] :70kohm 60°C[140°F] :48kohm 70°C[158°F] :34kohm 80°C[176°F] :24kohm 90°C[194°F] :17.5kohm 100°C[212°F] :13.0kohm 110°C[230°F] :9.8kohm</p>		

Part name	Symbols (functions)	Notes	Usage	Specifications	Check method
Thermistor	TH2	PQHY only	LEV1 is controlled based on the TH2, TH3, and TH6 values	Degrees Celsius $R_0 = 15k\Omega$ $R_{0/80} = 3460$ $R_t = 15 \exp\{3460 (\frac{1}{273+t} - \frac{1}{273})\}$ 0°C[32°F]: 15kohm 10°C[50°F]: 9.7kohm 20°C[68°F]: 6.4kohm 25°C[77°F]: 5.3kohm 30°C[86°F]: 4.3kohm 40°C[104°F]: 3.1kohm	Resistance check
	TH3 (Pipe temperature)	PQHY only	Controls defrosting during heating operation 1) Frequency control 2) LEV1 is controlled according to the amount of subcool at the heat exchanger outlet, which is calculated based on the HPS data and TH3 value.		
	TH7 (Water inlet temperature)		1) Detects water inlet temperature 2) Protects water heat exchanger from high and low temperatures 3) Controls water heat exchanger		
	TH8 (Water outlet temperature)		1) Detects water inlet temperature 2) Protects water heat exchanger from freezing up		
	TH5		Water heat exchanger is controlled based on the 63LS and TH5 values.		
	TH6	PQHY only	LEV1 is controlled based on the TH2, TH3, and TH6 values		
	THINV		Determines the LEV that controls refrigerant flow on the component cooler		
	THHS Inverter heat sink temperature		Controls inverter cooling fan based on THHS temperature	Degrees Celsius $R_{50} = 17k\Omega$ $R_{25/120} = 4016$ $R_t = 17 \exp\{4016 (\frac{1}{273+t} - \frac{1}{323})\}$ 0°C[32°F]: 161kohm 10°C[50°F]: 97kohm 20°C[68°F]: 60kohm 25°C[77°F]: 48kohm 30°C[86°F]: 39kohm 40°C[104°F]: 25kohm	

Part name	Symbols (functions)	Notes	Usage	Specifications	Check method
Solenoid valve	SV1a Discharge-suction bypass		1) High/low pressure bypass at start-up and stopping, and capacity control during low-load operation 2) High-pressure-rise prevention	AC208 - 230V Open while being powered/ closed while not being powered	Continuity check with a tester
	SV4a, SV4b, SV4d Heat exchanger capacity control	PQRY only	Controls heat source unit heat exchanger capacity		
	SV7a,7b Heat exchanger capacity control		Controls heat source unit heat exchanger capacity	AC208 - 230V Open while being powered/ closed while not being powered	
	SV7c Heat exchanger capacity control	P144 P168 P192 P216 P240 models only	Controls heat source unit heat exchanger capacity	AC208 - 230V Open while being powered/ closed while not being powered	
	SV9	PQRY only	High-pressure-rise prevention	AC208 - 230V Closed while being powered/ open while not being powered	
Heater	CH11		Heats the refrigerant in the compressor	Cord heater 1280 ohm 45W	Resistance check
4-way valve	21S4a		Changeover between heating and cooling	AC208-230V Dead: cooling cycle Live: heating cycle	Continuity check with a tester
	21S4b	P144 P168 P192 P216 P240 models only			
Electronic expansion valve	LEVINV		Controlling the refrigerant flow in the inverter cooling heat exchanger	12 VDC Stepping motor driven valve opening 0-480 pulses (direct driven)	Same as with the indoor LEV. The resistance values differs from that of the LEVs on indoor unit. (Refer to the section on Troubleshooting the LEV(page 355))
	LEV1 (for SC control)	PQHY only	Regulates the amount of bypass flow from the heat source unit liquid pipe during cooling		
	LEV6		Controls heat source unit heat exchanger capacity	12 VDC Stepping motor driven valve opening 41 - 3000 pulses	Refer to the section "Continuity Test with a Tester". Continuity between white and orange. Continuity between yellow, brown, and blue.
	LEV7				

2. Indoor Unit

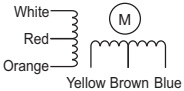
Part Name	Symbol (functions)	Notes	Usage	Specification	Check method
Linear expansion valve	LEV		1) Adjusts superheat at the indoor heat exchanger outlet during cooling 2) Adjusts subcool at the heat exchanger outlet of the indoor unit during heating	DC12V Opening of stepping motor driving valve 0-(1400) pulses	Refer to the section "Continuity Test with a Tester". Continuity between white, red, and orange. Continuity between yellow, brown, and blue. 
Thermistor	TH1 (Suction air temperature)		Indoor unit control (Thermo)	$R_0=15k\Omega$ $R_{0/80}=3460$ $R_t = 15 \exp\left\{3460\left(\frac{1}{273+t} - \frac{1}{273}\right)\right\}$ 0°C [32°F]:15kohm 10°C [50°F]:9.7kohm 20°C [68°F]:6.4kohm 25°C [77°F]:5.3kohm 30°C [86°F]:4.3kohm 40°C [104°F]:3.1kohm	Resistance check
	TH2 (Pipe temperature)		1) Indoor unit control (Frost prevention, Hot adjust) 2) LEV control during heating operation (subcool detection).		
	TH3 (Gas pipe temperature)		LEV control during cooling operation (superheat detection)		
	TH4 Outdoor air temperature)		Indoor unit control (Thermo)		
	Temperature sensor (Indoor air temperature)		Indoor unit control (Thermo)		

3. BC controller
(1) G type

Part name	Symbols (functions)	Part code	Usage	Specifications	Check method
Pressure sensor	PS1 (High pressure side)		1) Detects high pressure 2) LEV control	<p>Pressure 0~4.15 MPa [601psi] Vout 0.5~3.5V 0.071V/0.098 MPa [14psi] Pressure [MPa] =1.38 x Vout [V]-0.69 Pressure [psi] =(1.38 x Vout [V] - 0.69) x 145</p> <p>1 GND (Black) 2 Vout (White) 3 Vcc (DC5V) (Red)</p>	
	PS3 (Intermediate pressure)		1) Detects intermediate pressure 2) LEV control		
Thermistor	TH11 (Liquid inlet temperature)		LEV control (Liquid level control)	$R_0 = 15k\Omega$ $R_{0/80} = 3460$ $R_t = 15 \exp\left\{3460 \left(\frac{1}{273+t} - \frac{1}{273}\right)\right\}$ 0°C[32°F] : 15kohm 10°C[50°F] : 9.7kohm 20°C[68°F] : 6.4kohm 25°C[77°F] : 5.3kohm 30°C[86°F] : 4.3kohm 40°C[104°F] : 3.1kohm	
	TH12 (Bypass outlet temperature)		LEV control (Superheat)		
	TH15 (Bypass inlet temperature)		LEV control (Superheat)		
	TH16 (Liquid refrigerant temperature)		LEV control (Subcool)		
Solenoid valve	SVM1		Opens during cooling and defrost modes	AC208-230V Open while being powered/ closed while not being powered	Continuity check with a tester
	SV■A		Provides refrigerant to indoor unit in cooling operation		
	SV■B		Provides refrigerant to indoor unit in heating operation		
	SV■C		Provides refrigerant to indoor unit in cooling operation		
LEV	LEV1		1) Liquid level control 2) Pressure differential control	DC12V Opening of a valve driven by a stepping motor 0-2000 pulses	Same as indoor LEV
	LEV3				

(2) GA type

Part name	Symbols (functions)	Part code	Usage	Specifications	Check method
Pressure sensor	PS1 (High pressure side)		1) Detects high pressure 2) LEV control	<p>Pressure 0~4.15 MPa [601psi] Vout 0.5~3.5V 0.071V/0.098 MPa [14psi] Pressure [MPa] =1.38 x Vout [V]-0.69 Pressure [psi] =(1.38 x Vout [V] - 0.69) x 145</p> <p>1 GND (Black) 2 Vout (White) 3 Vcc (DC5V) (Red)</p>	
	PS3 (Intermediate pressure)		1) Detects intermediate pressure 2) LEV control		
Thermistor	TH11 (Liquid inlet temperature)		LEV control (Liquid level control)	$R_0 = 15k\Omega$ $R_{0/80} = 3460$ $R_t = 15 \exp\left\{3460 \left(\frac{1}{273+t} - \frac{1}{273}\right)\right\}$ <p>0°C[32°F] : 15kohm 10°C[50°F] : 9.7kohm 20°C[68°F] : 6.4kohm 25°C[77°F] : 5.3kohm 30°C[86°F] : 4.3kohm 40°C[104°F] : 3.1kohm</p>	
	TH12 (Bypass outlet temperature)		LEV control (Superheat)		
	TH15 (Bypass inlet temperature)		LEV control (Superheat)		
	TH16 (Liquid refrigerant temperature)		LEV control (Subcool)		
Solenoid valve	SVM1		Opens during cooling and defrost modes	AC208-230V Open while being powered/ closed while not being powered	Continuity check with a tester
	SVM2		Pressure differential control		
	SV■A		Provides refrigerant to indoor unit in cooling operation		
	SV■B		Provides refrigerant to indoor unit in heating operation		
	SV■C		Provides refrigerant to indoor unit in cooling operation		
LEV	LEV1 LEV2		1) Liquid level control 2) Pressure differential control	DC12V Opening of a valve driven by a stepping motor 0-2000 pulses	Same as indoor LEV
	LEV3		Subcool control		

(3) GB type

Part name	Symbols (functions)	Part code	Usage	Specifications	Check method
Thermistor	TH12 (Bypass outlet temperature)		LEV control (Superheat)	$R_0 = 15k\Omega$ $R_{0/80} = 3460$ $R_t = 15 \exp\left\{3460 \left(\frac{1}{273+t} - \frac{1}{273}\right)\right\}$	
	TH15 (Bypass inlet temperature)		LEV control (Superheat)	0°C[32°F] : 15kohm 10°C[50°F] : 9.7kohm 20°C[68°F] : 6.4kohm 25°C[77°F] : 5.3kohm 30°C[86°F] : 4.3kohm 40°C[104°F] : 3.1kohm	
Solenoid valve	SV■A		Provides refrigerant to indoor unit in cooling operation	AC208-230V Open while being powered/ closed while not being powered	Continuity check with a tester
	SV■B		Provides refrigerant to indoor unit in heating operation		
	SV■C		Provides refrigerant to indoor unit in cooling operation		
LEV	LEV3		Pressure differential control	DC12V Opening of a valve driven by a stepping motor 0-2000 pulses	Same as indoor LEV

(4) HA type

Part name	Symbols (functions)	Part code	Usage	Specifications	Check method
Pressure sensor	PS1 (High pressure side)		1) Detects high pressure 2) LEV control	<p>Pressure 0~4.15 MPa [601psi] Vout 0.5~3.5V 0.071V/0.098 MPa [14psi] Pressure [MPa] =1.38 x Vout [V]-0.69 Pressure [psi] =(1.38 x Vout [V] - 0.69) x 145</p> <p>1 GND (Black) 2 Vout (White) 3 Vcc (DC5V) (Red)</p>	
	PS3 (Intermediate pressure)		1) Detects intermediate pressure 2) LEV control		
Thermistor	TH11 (Liquid inlet temperature)		LEV control (Liquid level control)	$R_0 = 15k\Omega$ $R_{0/80} = 3460$ $R_t = 15 \exp\left\{3460 \left(\frac{1}{273+t} - \frac{1}{273}\right)\right\}$ 0°C[32°F] : 15kohm 10°C[50°F] : 9.7kohm 20°C[68°F] : 6.4kohm 25°C[77°F] : 5.3kohm 30°C[86°F] : 4.3kohm 40°C[104°F] : 3.1kohm	
	TH12 (Bypass outlet temperature)		LEV control (Superheat)		
	TH15 (Bypass inlet temperature)		LEV control (Superheat)		
	TH16 (Liquid refrigerant temperature)		LEV control (Subcool)		
Solenoid valve	SVM1		Opens during cooling and defrost modes	AC208-230V Open while being powered/ closed while not being powered	Continuity check with a tester
	SVM1b		Opens during cooling and defrost modes		
	SVM2		Pressure differential control		
	SVM2b		Pressure differential control		
	SV■A		Provides refrigerant to indoor unit in cooling operation		
	SV■B		Provides refrigerant to indoor unit in heating operation		
	SV■C		Provides refrigerant to indoor unit in cooling operation		
LEV	LEV1		1) Liquid level control 2) Pressure differential control	DC12V Opening of a valve driven by a stepping motor 0-2000 pulses	Same as indoor LEV
	LEV3		Subcool control		

(5) HB type

Part name	Symbols (functions)	Part code	Usage	Specifications	Check method
Thermistor	TH12 (Bypass outlet temperature)		LEV control (Superheat)	$R_0 = 15k\Omega$ $R_{0/80} = 3460$ $R_t = 15 \exp\left\{3460 \left(\frac{1}{273+t} - \frac{1}{273}\right)\right\}$	
	TH15 (Bypass inlet temperature)		LEV control (Superheat)	0°C[32°F] : 15kohm 10°C[50°F] : 9.7kohm 20°C[68°F] : 6.4kohm 25°C[77°F] : 5.3kohm 30°C[86°F] : 4.3kohm 40°C[104°F] : 3.1kohm	
Solenoid valve	SV■A		Provides refrigerant to indoor unit in cooling operation	AC208-230V Open while being powered/ closed while not being powered	Continuity check with a tester
	SV■B		Provides refrigerant to indoor unit in heating operation		
	SV■C		Provides refrigerant to indoor unit in cooling operation		
LEV	LEV3		Pressure differential control	DC12V Opening of a valve driven by a stepping motor 0-2000 pulses	Same as indoor LEV

VII Control

[1] Functions and Factory Settings of the Dipswitches	159
[2] Controlling the Heat source Unit.....	166
[3] Controlling BC Controller	181
[4] Operation Flow Chart.....	182



[1] Functions and Factory Settings of the Dipswitches

1. Heat source unit

(1) Control board

Switch		Function	Function according to switch setting		Switch setting timing	Units that require switch setting (Note 2)
			OFF	ON		
SWU	1-2	Unit address setting	Set to 00 or 51-100 with the dial switch		Before power on	C
SW5	1	Centralized control switch	Without connection to the centralized controller	With connection to the centralized controller	Before power on	B
	2	Deletion of connection information	Normal control	Deletion	Before power on	A
	3	-	Preset before shipment			-
	4	-				-
	5	-				-
	6	-				-
	7	-				-
SW6	7	Performance-priority/low-noise mode setting	Performance-priority mode (Note 3)	Quiet-priority mode	Anytime after power on	A
	8	Low-noise mode/step demand switching	Low-noise mode (Note 4)	Step demand mode	Before power on	C
	10	Self-diagnosis/function setting No. display setting	Self-diagnosis monitor display	Function setting No. display	Anytime after power on	C

Note

- Unless otherwise specified, leave the switch to OFF where indicated by "-" or where the cells are blank, which may be set to OFF for a reason.
- A: Only the switch on OC needs to be set for the setting to be effective.
B: The switches on both the OC and OS need to be set to the same seeing for the setting to be effective.
C: The switches on both the OC and OS need to be set.
- When set to the performance-priority mode, the low-noise mode will be terminated, and the units will operate in the normal mode.
Cooling: Ambient temperature or the high pressure is high.
Heating: Ambient temperature or the low pressure is low.(page 27)
- Operation noise is reduced by controlling the compressor frequency.
Requires CN3D to be set.(page 27)

Switch		Function		Function according to switch setting		Switch setting timing	Units that require switch setting (Note 2)	
				OFF (LED3 Unlit)	ON (LED3 Lit)			
SW4 SW6-10: OFF	1-10	Self-diagnosis/operation monitor		Refer to the LED monitor display on the heat source unit heat source unit board.		Anytime after power on	C	
SW4 1-10 [0:OFF, 1:ON] (Note 1) SW6-10: ON	No.769	1000000011	Test run mode: ON/ OFF		Stops all ICs	Sends a test-run signal to all IC	Anytime after power on	A
	No.810	0101010011	Outputs circulating water flow rate control signal		0 V: Fully open 10 V: Fully closed	0 V: Fully closed 10 V: Fully open	After power on and while the compressor is stopped	C
	No.832	0000001011	Cumulative compressor operation time deletion		Retained	Cleared	Anytime after power on (OFF→ON)	C
	No.896	0000000111	Clearance of error history	OC	Retained (IC/OC)	Deleted (IC/OC)	Anytime after power on (OFF→ON)	C
				OS	Retained (OS)	Deleted (OS)		
	No.901	1010000111	Changes signal output when all heat source units (OC/OS) go into Thermo-OFF		Water flow rate control valve remains open when all heat source units (OC/OS) go into Thermo-OFF. (Minimum water flow rate)	Water flow rate control valves will close when all heat source units (OC/OS) go into Thermo-OFF.	After power on and while the compressor is stopped	C
	No.912	0000100111	Pump down function		Normal control	Pump down operation	After being energized and while the compressor is stopped	A
	No.914	0100100111	CN51-3,5 signal output switch		Heat source unit error output	Water heat exchanger coupling prevention output	Anytime after power on	C
	No.917	1010100111	Power on signal output switch		During Thermo-ON	During Thermo-OFF	Anytime after power on	A
	No.921	1001100111	Temperature unit display		°C	°F	Anytime after power on	C
	No.922	0101100111	Refrigerant amount adjustment		Normal control	Refrigerant amount adjust mode	Anytime after power on (except during initial start-up/becomes ineffective 60 minutes after compressor started up.	A
No.932	0010010111	Heating backup		Disabled	Enabled	Anytime after power on	A	
No.981	1010101111	Water heat exchanger freeze prevention		Ineffective	Effective Note 4	Anytime after power on	A	

Note

- 1) To change the settings, set SW6-10 to ON, set SW4, and press and hold SWP01 for 2 seconds or longer (OFF→ON). LED3 will light up when the switch setting is ON, and lights off when OFF. Use the LED3 display to confirm that the settings are properly made. The settings will need to be set again when the control board is replaced. Write down the settings on the electrical wiring drawing label.
- 2) A: OC: Only the switch on OC needs to be set for the setting to be effective.
B: OC: The switches on both the OC and OS need to be set to the same seeing for the setting to be effective.
C: OC: The switches on both the OC and OS need to be set.
D: OC: The switch on either the OC or OS needs to be set.
- 3) The settings that are configured with SW4 (SW6-10: ON) will automatically be stored on the indoor units that support the new function*. The stored settings will automatically be restored when the heat source unit control board is replaced. If none of the connected indoor units supports the new function, no configuration information will be saved. If this is the case, manually record the settings configuration on the control box panel.
*The new function is supported on most units that are manufactured in April of 2012 and later. Depending on the model, this function may be added on later date. Ask your dealer for further details.

- 4) If the inlet water temperature (TH7) drops below 5°C [41°F] while the compressor is stopped, or the outlet water temperature (TH8) drops below 3°C [37°F], Cooling-only operation will be performed to prevent freeze-ups. This operation will terminate when one of the following conditions is met: 1) Both the TH7 and TH8 readings (water temperature) exceed 10°C [50°F], 2) Two hours have passed since the beginning of the Cooling-only operation, or 3) Signal to resume normal operation is received.
- 5) To use the functions above, be sure to set the switches in the following combinations.
 - *Set SW4(901) to OFF and SW4(917) to ON to keep the pumps on all heat source units (OC/OS) to operate during Thermo-OFF and to keep the water flow rate control valve open.
 - *Set SW4(901) to ON and SW4(917) to OFF to stop the pumps on all heat source units (OC/OS) during Thermo-OFF and to close the water flow rate control valve.

(2) INV board

1) YLMU

Functions are switched with the following connector.

Connector	Function	Function according to connector		Setting timing	
		Enabled	Disabled	Enabled	Disabled
CN6 short-circuit connector	Enabling/disabling the following error detection functions; ACCT sensor failure (5301 Detail No. 115) ACCT sensor circuit failure (5301 Detail No.117) IPM open/ACCT erroneous wiring (5301 Detail No. 119) Detection of ACCT erroneous wiring (5301 Detail No.120)	Error detection enabled	Error detection disable (No load operation is possible.)	Anytime after power on	

Note

- CN6 short-circuit connector is mated with the mating connector.
- Leave the short-circuit connector on the mating connector during normal operation to enable error detection and protect the equipment from damage.

2) TLMU

Switch		Function	Function according to switch setting		Switch setting timing	
			OFF	ON		
SW1	1	Enabling/disabling the following error detection functions; ACCT/DCCT sensor failure (5301 Detail No. 115, 116) ACCT/DCCT sensor circuit failure (5301 Detail No.117,118) IPM open/Disconnected CNCT2 (5301 Detail No. 119) Detection of erroneous wiring (5301 Detail No.120)	Error detection enabled	Error detection disable (No load operation is possible.)	Anytime after power on	
	2	-	-	-	-	-
	3	-	-	-	-	-
	4	-	-	-	-	-
	5	-	-	-	-	-
	6	-	-	-	-	-

Note

- All are set to OFF at factory shipment. Unless otherwise specified, set the switch to OFF where indicated by "-", which may be set to a certain setting for a reason.
- Leave SW1-1 to OFF during normal operation. If it is set to ON, errors cannot be detected and the unit may be damaged.

2. Function of the switch (Indoor unit)

(1) Dipswitches

1) SW1,3

Switch	Function	Function according to switch setting		Switch setting timing		Notes
		OFF	ON	OFF	ON	
SW1	1	Room temperature detection position	Indoor unit inlet	Built-in sensor on the remote controller	While the unit is stopped (Remote controller OFF)	Set to ON (built-in sensor on the remote controller) on All Fresh (PEFY-P-NMHU-E-F) model units
	2	Clogged filter detection	Not available	Available		
	3	Filter check reminder time setting	100h	2500h		
	4	Outside air intake	Disabled	Enabled		Always set to OFF on PKFY-P-NBMU-E model units
	5	Remote display option	Fan output	Thermo-ON signal		
	6	Humidifier control	During heating operation	Always on while in the heating mode		
	7	Fan speed setting for Heating Thermo-OFF	Very Low	Low		
		Forced heating operation at OA temp of 5°C or below	Not available	Available		Applicable to All Fresh model units (PEFY-P-NMHU-E-F) only
	8	Fan speed setting for Heating Thermo-OFF	According to the SW1-7 setting	Preset speed		
		-	-	-		Applicable to All Fresh model units (PEFY-P-NMHU-E-F) only
9	Self-recovery after power failure	Disabled	Enabled			
10	Power source start-stop	Disabled	Enabled			
SW3	1	Unit model selection	Heat pump	Cooling only	While the unit is stopped (Remote controller OFF)	
	2	Louver	Not available	Available		
	3	Vane	Not available	Available		
	4	Vane swing function	Not available	Available		Always set to OFF on PKFY-P-NBMU-E model units
	5	-	-	-		
	6	Vane angle limit setting for cooling operation	Downblow B,C	Horizontal		Always set to Downblow B or C on PKFY-P-NBMU-E model units
		Initial vane position	Enabled	Disabled		PLFY-P-NLMU-E model only
	7	Automatic LEV value conversion function	Not available	Available		
	8	Heating 4 °C[7.2 °F] up	Enabled	Disabled		Set to OFF on floor-standing (PFY) type units
	9	SHm setting	2	5		The setting depends on the model and type.
10	SCm setting	10	15	The setting depends on the model and type.		

Note 1. Settings in the shaded areas are factory settings.(Refer to the table below for the factory setting of the switches whose factory settings are not indicated by the shaded cells.)

Note 2. If both SW1-7 and SW1-8 are set to ON, the fan remains stopped during heating Thermo-OFF.

To prevent incorrect temperature detection due to a build-up of warm air around the indoor unit, use the built-in temperature sensor on the remote controller (SW1-1) instead of the one on the indoor unit inlet thermistor.

Note 3. By setting SW3-1, SW1-7, and SW1-8 to a certain configuration, the fan can be set to remain stopped during cooling Thermo-OFF. See the table below for details.

Switch setting			Fan speed during Thermo-OFF		Cooling-only/heat pump
SW3-1	SW1-7	SW1-8	Heating	Cooling	
OFF	OFF	OFF	Very Low	Preset speed	Heat pump
	ON	OFF	Low		
	OFF	ON	Preset speed		
	ON	ON	Stop		
ON	OFF	OFF	-	Preset speed	Cooling-only
	ON	OFF	-		
	OFF	ON	-	Stop	Heat pump
	ON	ON	Stop	Stop	

(2) Address switch

Actual indoor unit address setting varies in different systems. Refer to the installation manual for the heat source unit for details on how to make the address setting.

Each address is set with a combination of the settings for the 10's digit and 1's digit.

(Example)

When setting the address to "3", set the 1's digit to 3, and the 10's digit to 0.

When setting the address to "25", set the 1's digit to 5, and the 10's digit to 2.

3. Function of the switch <Remote controller>

(1) MA remote controller (PAR-20MAU)

The SW is located at the bottom of the remote controller under the cover. Operate the switches to perform the remote controller main/sub setting or other function settings. Normally, do not change the settings of switches other than the SW1 (main/sub switching switch). (All the switches are set to "ON" at factory setting.)

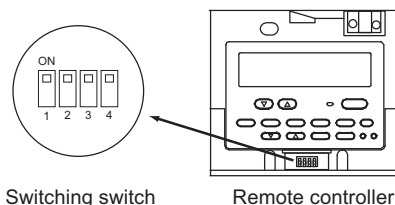

The figure at left shows that the switches 1 through 5 are set to ON and 6 through 10 are set to OFF.

Switch	Function	ON	OFF	Operation by switch settings	Switch setting timing
1	Remote controller main/sub setting	Main	Sub	When two remote controllers are connected to one group, set either of the remote controllers to "Sub".	Before power on
2	At power on of the remote controller	Normal startup	Timer mode startup	When the program timer (only few stock products are available) is connected, set to "Timer mode startup" to resume the operation with timer mode after power is restored.	Before power on
3	Cooling/heating display set by automatic setting	Displayed	Not displayed	When the automatic mode is set and the "Cooling"/"Heating" display is not necessary, set to "Not displayed".	Before power on
4	Suction temperature display (discharge temperature display)	Displayed	Not displayed	When the suction temperature (discharge temperature) display is not necessary, set to "Not displayed".	Before power on

Note

The MA remote controller (PAR-21MAAU, PAR-30MAAU) does not have the switches listed above. Refer to the installation manual for the function setting.

(2) ME remote controller (PAR-F27MEA-US)

Set the address of the remote controller with the rotary switch.

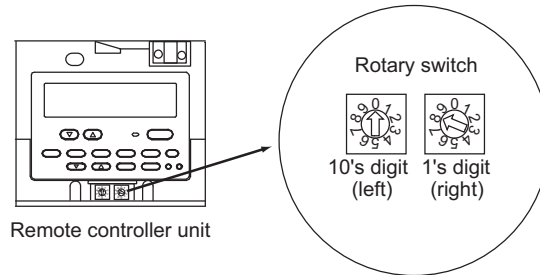

Example: In case of address 108

	Address setting range	Setting method
Main remote controller	101-150	Add 100 to the smallest address of all the indoor units in the same group.
Sub remote controller	151-200	Add 150 to the smallest address of all the indoor units in the same group.
Setting of rotary switch	Address No.	
01-99*1	101-199 with the 100's digit automatically being set to 1*2	
00	200	

*1. At factory shipment, the rotary switch is set to 01.

*2. The address range that can be set with the ME remote controller is between 101 and 200. When the dials are set to a number between 01 and 99, the 100's digit is automatically set to [1]. When the dials are set to 00, the 100's digit is automatically set to [2].

Note

To set addresses, use a precision slotted screw driver [2.0 mm [0.08 in] (w)], and do not apply than 19.6N. The use of any other tool or applying too much load may damage the switch.

4. Switch functions <BC controller> (Control board)

Switch	Function	Function according to switch setting		Switch setting timing	
		OFF	ON		
SW4	1	Model setting	R410A	-	Always leave this switch to OFF.
	2 - 5	-	-	-	-
	6	No. of ports	1	2	Before being energized
	7, 8	-	-	-	-
SW5	1 - 6	-	-	-	-
	7	-	-	-	-
	8	-	-	-	-

[2] Controlling the Heat source Unit

-1- Outline of Control Method

- The heat source units are designated as OC and OS in the order of capacity from large to small (if two or more units have the same capacity, in the order of address from small to large).
- The setting of heat source unit can be verified by using the self-diagnosis switch SW4 (SW6-10: OFF).

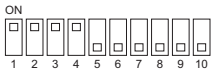
SW4 (SW6-10: OFF)	Display
	<ul style="list-style-type: none"> ■ The unit is designated as the OC: "OC" appears on the display. ■ The unit is designated as OS: "OS" appears on the display

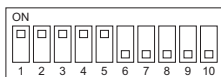

The figure at left shows that the switches 1 through 5 are set to ON and 6 through 10 are set to OFF.

- The OC determines the operation mode and the control mode, and it also communicates with the indoor units.
- The OS exercises autonomous distributed control (over defrost, error detection, and actuator control etc.) according to the operation/control mode signals that are sent from the OC.

-2- Startup sequence rotation

- At the initial startup, heat source units start up in the order of "OC and OS."
- Startup sequence rotation is performed while all the indoor units are stopped. (Even after two hours of operation, startup sequence rotation is not performed while the compressor is in operation.)
In a system with multiple heat source units (OC and OS), when the integrated operation time of the unit in operation (either OC or OS) reaches one hour during a cooling operation at low outside temperature, that unit will stop and the other unit will go into operation.
- Refer to [-12-Control at Initial Start-up] for the initial startup.
- Performing startup sequence rotation does not change the basic operation of OC and OS. Only startup sequence is changed.
- Startup sequence of the heat source units can be checked with the self-diagnosis switch SW4 (SW6-10: OFF) on the OC.

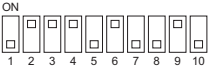
SW4 (SW6-10: OFF)	Display
	<ul style="list-style-type: none"> ■ OC→OS: "OC" and the "OC" address appear alternately on the display. ■ OS→OC: "OS" and the "OS" address appear alternately on the display.

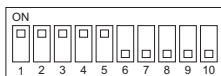

The figure at left shows that the switches 1 through 5 are set to ON and 6 through 10 are set to OFF.

-3- Initial Control

- When the power is turned on, the initial processing of the microcomputer is given top priority.
- During the initial processing, control processing of the operation signal is suspended. (The control processing is resumed after the initial processing is completed. Initial processing involves data processing in the microcomputer and initial setting of each of the LEV opening. This process will take up to 5 minutes.)
- During the initial processing, the LED monitor on the heat source unit's control board displays S/W version -> refrigerant type -> heat pump -> cooling only and capacity -> and communication address in turn every second.

-4- Control at Start-up

- The upper limit of frequency during the first 3 minutes of the operation is 50 Hz.
- When the power is turned on, normal operation will start after the initial start-up mode (to be described later) has been completed (with a restriction on the frequency).

-5- Bypass Control

Bypass solenoid valves, which bypass the high- and low- pressure sides, perform the following functions.

(1) Bypass solenoid valve (SV1a) (ON = Open)

Operation	SV1a	
	ON	OFF
When the compressor on each heat source unit starts up	ON for 4 minutes.	
After the restoration of thermo or 3 minutes after restart	ON for 4 minutes.	
During cooling or heating operation with the compressor stopped	Always ON. Exception: OFF when 63HS1-63LS is 0.2MPa[29psi] or less	
After the operation has stopped	ON for 3 minutes. Exception: OFF when 63HS1-63LS is 0.2MPa[29psi] or less	
During defrost operation	ON	
While the compressor is operating at the minimum frequency and when the low pressure (63LS) drops (3 or more minutes after compressor startup)	When low pressure (63LS) drops below 0.23MPa[33psi].	When low pressure (63LS) exceeds 0.38MPa[55psi].
When high pressure (63HS1) rises	When 63HS1 exceeds 3.62MPa[525psi]	When 63HS1 is or below 3.43MPa[497psi] and 30 seconds have passed

(2) Bypass solenoid valve (SV9) (ON = Close)

Operation	SV9	
	OFF	ON
After the operation has stopped	OFF while the unit is stopped	ON while the unit is in operation

-6- Compressor Frequency Control

- Depending on the capacity required, the frequency of the compressor is controlled to keep constant evaporation temperature (0°C [32°F] = 0.71 MPa [103 psi]) during cooling operation, and condensing temperature (49°C [120°F] = 2.88 MPa [418 psi]) during heating operation.
- The table below summarizes the operating frequency ranges of the inverter compressor during normal operation.
- The OS in the multiple-heat source-unit system operates at the actual compressor frequency value that is calculated by the OS based on the preliminary compressor frequency value that the OC determines.

Model	Frequency/cooling (Hz)		Frequency/heating (Hz)	
	Max	Min	Max	Min
P72 model	40	10	42	10
P96 model	56	10	52	10
P120 model	73	10	64	10
P144 model	86	16	72	16
P168 model	99	16	87	16
P192 model	111	16	101	16
P216 model	134	18	109	18
P240 model	149	18	124	18

Note

The maximum frequency during heating operation is affected by the water temperature to a certain extent.

(1) Pressure limit

The upper limit of high pressure (63HS1) is preset, and when it exceeds the upper limit, the frequency is decreased every 15 seconds.

- The actuation pressure is when the high-pressure reading on 63HS1 is 3.58MPa[519psi].

(2) Discharge temperature limit

Discharge temperature (TH4) of the compressor in operation is monitored, and when it exceeds the upper limit, the frequency is decreased every minute.

- Operating temperature is 115°C [239°F].

(3) Periodic frequency control

Frequency control other than the ones performed at start-up, upon status change, and for protection is called periodic frequency control (convergent control) and is performed in the following manner.

Periodic control cycle

Periodic control is performed after the following time has passed

- 30 seconds after compressor start-up
- 30 seconds after frequency control based on discharge temperature or pressure limit

The amount of frequency change

The amount of frequency change is controlled to approximate the target value based on the evaporation temperature (Te) and condensing temperature (Tc).

-7- Refrigerant Recovery Control <PQHY>

Recovery of refrigerant is performed during heating operation to prevent the refrigerant from accumulating inside the unit while it is stopped (unit in fan mode), or inside the indoor unit that is in cooling mode or in heating mode with thermo off. It is also performed during cooling operation to prevent an excessive amount of refrigerant from accumulating in the heat source heat exchanger.

(1) During heating operation

Starting refrigerant recovery mode

The refrigerant recovery mode in heating starts when all of the following three conditions are met:

- 15 minutes have passed since the completion of previous refrigerant recovery.
- TH4 > 115°C [239°F]
- Frequencies below 50 Hz

Refrigerant recovery

- 1) Refrigerant is recovered with the LEV on the applicable indoor unit (unit under stopping mode, fan mode, cooling, heating with thermo off) being opened for 30 seconds.

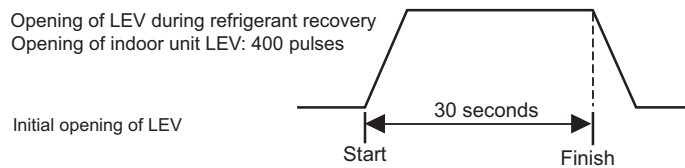

- 2) Periodic capacity control of the heat source units and periodic LEV control of the indoor units will be suspended during refrigerant recovery operation; they will be performed after the recovery has been completed.

(2) During cooling operation

Starting refrigerant recovery mode

The refrigerant recovery mode starts when all the following conditions are met:

- 30 minutes have passed since the completion of previous refrigerant recovery.
- When the unit keeps running for 3 minutes in a row or more with high discharge temperature
- TH4 > 105°C [221°F] or 63HS1 > 3.43 MPa [497 psi] (35 kg/cm²G) and SC0 > 10°C [18°F]

Refrigerant recovery

The opening of LEV1 is increased and periodic control begins again.

-8- Refrigerant Recovery Control <PQRY>

Refrigerant recovery is performed for each BC port during heating operation to prevent the refrigerant from accumulating inside the units that are stopped (in the fan mode), in the cooling mode, or in the heating Thermo-OFF mode. It is also performed during cooling operation to prevent an excessive amount of refrigerant from accumulating in the heat source heat exchanger.

Starting criteria for the refrigerant recovery cycle (during Cooling-only, Cooling-main, Heating-only, or Heating-main mode)

The refrigerant recovery mode starts when all of the following conditions are met:

- 1) When 5 minutes have passed in the Heating-only or Heating-main mode or 30 seconds have passed in the Cooling-only or Cooling-main mode since the completion of the previous refrigerant recovery cycle AND the when following conditions are met.
TH4 > 105°C [221°F]
- 2) When the port is not in the 4-minute restart delay mode

Starting criteria for the refrigerant recovery cycle (during Cooling-only, Cooling-main, Heating-only, or Heating-main mode)

- 1) When the port is in the cooling Thermo-OFF, fan, or stop mode
SV■C at the port turns on for 30 seconds. (■ indicates port No.)
- 2) The opening of LEV1 and LEV3 is increased.

-9- Capacity Control of Heat Exchanger<PQHY>

(1) Control method

- Depending on the capacity required, the heat exchanger capacity of the heat source unit is controlled by the solenoid valve and LEV to keep a constant condensing temperature of (water temperature +10°C [50°F]) during cooling operation and a constant evaporation temperature of (4°C [39°F] =0.80 <Pa [116psi]) during heating operation.
- The OS in the multiple-heat source-unit system operates at the actual heat exchanger capacity control value that is calculated by the OS based on the preliminary heat exchanger capacity control value that the OC determines.

(2) Heat source unit heat exchanger capacity control patterns

Model	Operation mode		Operation pattern	Solenoid valve					LEV	
	PQRY	PQHY		SV4a	SV4b	SV4d	SV7a	SV7b	LEV6	LEV7
P72-P120 models	Cooling-only Cooling-main	-	1	OFF	OFF	ON	OFF	OFF	41 pulses	41-3000 pulses
			2	OFF	OFF	ON	OFF	OFF		
			3	OFF	OFF	OFF	ON	ON		
			4	OFF	OFF	OFF	OFF	ON		
			5	OFF	OFF	OFF	OFF	ON		
			6	OFF	OFF	OFF	ON	OFF		
			7	OFF	OFF	OFF	ON	OFF		
			8	OFF	OFF	OFF	ON	OFF		
			9	OFF	OFF	OFF	ON	OFF		
	Cooling-only	Cooling	10	OFF	OFF	OFF	OFF	OFF		
Heating-only Heating-main	Heating	1	OFF	OFF	OFF	OFF	OFF	41-3000pulses	PQRY: 41 pulses PQHY: 3000 pulses	

Model	Operation mode		Operation pattern	Solenoid valve					LEV	
	PQRY	PQHY		SV4a	SV4b	SV4d	SV7a	SV7b	LEV6	LEV7
P144-P240 models	Cooling-only Cooling-main		1	OFF	ON	ON	ON	ON	41 pulses	41-3000 pulses (SV7c*1)
			2	OFF	ON	ON	ON	OFF		
			3	OFF	ON	ON	ON	OFF		
			4	OFF	ON	ON	OFF	OFF		
			5	OFF	ON	OFF	OFF	ON		
			6	OFF	OFF	ON	ON	ON		
			7	OFF	OFF	ON	ON	ON		
			8	OFF	OFF	ON	OFF	ON		
			9	OFF	OFF	ON	ON	OFF		
			10	OFF	OFF	ON	ON	OFF		
			11	OFF	OFF	ON	OFF	OFF		
			12	OFF	OFF	ON	OFF	OFF		
			13	OFF	OFF	OFF	ON	ON		
			14	OFF	OFF	OFF	OFF	ON		
			15	OFF	OFF	OFF	OFF	ON		
			16	OFF	OFF	OFF	ON	OFF		
			17	OFF	OFF	OFF	ON	OFF		
			18	OFF	OFF	OFF	ON	OFF		
			19	OFF	OFF	OFF	ON	OFF		
			20	OFF	OFF	OFF	ON	OFF		
			21	OFF	OFF	OFF	ON	OFF		
			22	OFF	OFF	OFF	ON	OFF		
			23	OFF	OFF	OFF	ON	OFF		
			24	OFF	OFF	OFF	ON	OFF		
		Cooling-only	Cooling	25	OFF	OFF	OFF	OFF	OFF	
	Heating-only Heating-main	Heating	1	OFF	OFF	OFF	OFF	OFF	41-3000 pulses	PQRY: 41 pulses (SV7c: OFF) PQHY: 3000 pulses (SV7c: ON)

*1 Solenoid valve SV7c may open to increase the refrigerant flow to the heat exchanger.

-10- Subcool Coil Control (Linear Expansion Valve <LEV1>) <PQHY only>

- ♦The OC, OS1, and OS2 controls the subcool coil individually.
- ♦The LEV is controlled every 30 seconds to maintain constant the subcool at the heat source unit heat exchanger outlet that is calculated from the values of high pressure (63HS1) and liquid piping temperature (TH3), or the superheat that is calculated from the values of low pressure (63LS) and the bypass outlet temperature (TH2) of the subcool coil.
- ♦LEV opening is controlled based on the values of the inlet (TH6) and the outlet (TH3) temperatures of the subcool coil, high pressure (63HS1), and discharge temperature (TH4). In a single-heat source-unit system, the LEV is closed (0) in the heating mode, while the compressor is stopped, and during cooling Thermo-OFF. In a multiple-heat source-unit system, the LEV closes (0) during heating operation, while the compressor is stopped, or during cooling Thermo-OFF. The LEV opens to a specified position when 15 minutes have passed after Thermo-OFF. (65 pulses)

-11- Refrigerant flow control (Linear expansion valve <LEV7>)<PQHY only>

- ♦Refrigerant flow is controlled by each unit in the combined models during heating. Refrigerant flow control is performed by the OC, OS1, and OS2 individually. The valve opens to a specified angle during cooling (Opening: 3000 pulses)
- ♦Valve opening is controlled based on the values of high pressure (63HS1), discharge temperature (TH4), low pressure(63LS), and piping temperature (TH5).
- ♦The valve moves to the predetermined position while the unit is stopped.

-12- Control at Initial Start-up

- ♦When started up for the first time before 12 hours have elapsed after power on, the unit goes into the initial startup mode.
- ♦At the completion of the initial operation mode on the OC and OS, they will go into the normal control mode.

1. Flowchart of initial operation

(1) System with a single heat-source unit

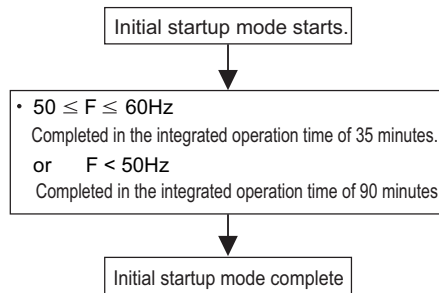

(2) System with two heat-source units

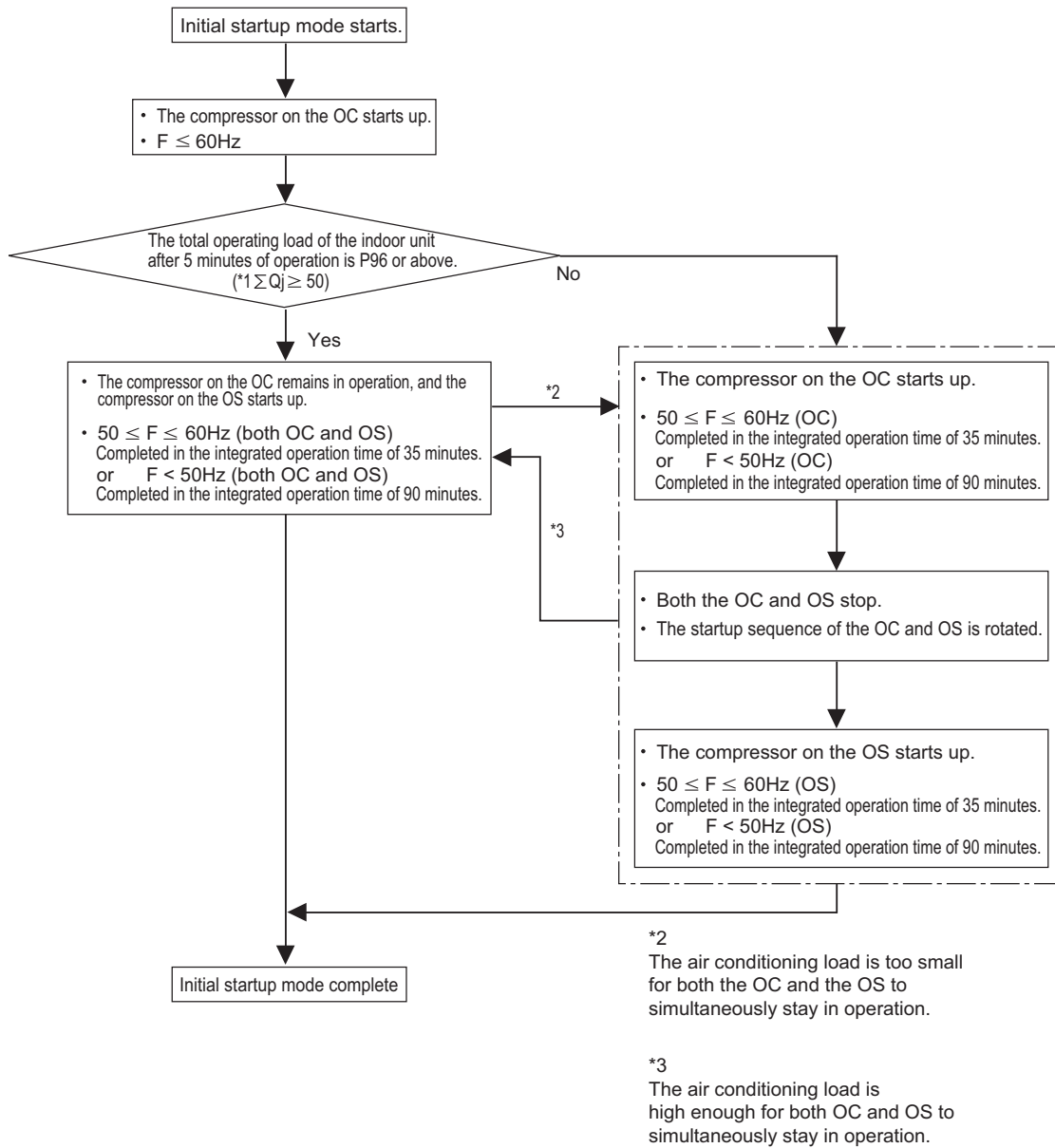

*1 ΣQj: Total capacity (model name) code

-13- Emergency Operation Mode

1. Problems with the heat source unit

- ♦Emergency operation mode is a temporary operation mode in which the heat source unit that is not in trouble operates when one of the heat source units in the system with two heat-source units is in trouble or when one or two of the heat source units in the system with three heat-source units are in trouble.
- ♦This mode can be started by performing an error reset via the remote controller.

(1) Starting the emergency operation

- 1) When an error occurs, the error source and the error code will be displayed on the display on the remote controller.
- 2) The error is reset using the remote controller.
- 3) If an error code appears that permits an emergency operation in step 1) above, (See the table below.), the retry operation starts.
- 4) If the same error is detected during the retry operation (step 3 above), an emergency operation can be started by resetting the error via the remote controller.

Error codes that permit an emergency operation (Applicable to both OC and OS)

Trouble source		Error codes that permit an emergency operation	Error code description
Compressor Inverter		0403	Serial communication error
		4220	Bus voltage drop
		4230	Heatsink overheat protection
		4240	Overload protection
		4250	Overcurrent relay trip
		5110	Heatsink temperature sensor failure (THHS)
		5301	Current sensor/circuit failure
Thermistor	TH2	5102	Subcool heat exchanger bypass outlet temperature sensor failure
	TH3	5103	Pipe temperature sensor failure
	TH4	5104	Discharge temperature sensor failure
	TH5	5105	Accumulator inlet temperature sensor failure
	TH6	5106	Subcool heat exchanger liquid outlet sensor failure
	TH7	5107	Outside air temperature sensor failure
	TH8	5108	Water outlet temperature sensor fault
Power		4102	Open phase
		4115	Power supply sync signal abnormality

Emergency operation pattern (2 heat source units)

		OC failure pattern	OS failure pattern
OC		Trouble	Normal
OS		Normal	Trouble
Emergency operation	Cooling	Permitted	Permitted
	Heating	Permitted	Permitted
Maximum total capacity of indoor units (Note 1)		60%	

(2) Ending the emergency operation

1) End conditions

When one of the following conditions is met, emergency operation stops, and the unit makes an error stop.

- ♦When the integrated operation time of compressor in cooling mode has reached four hours.
- ♦When the integrated operation time of compressor in heating mode has reached two hours.
- ♦When an error is detected that does not permit the unit to perform an emergency operation.

2) Control at or after the completion of emergency operation

- ♦At or after the completion of emergency operation, the compressor stops, and the error code reappears on the remote controller.
- ♦If another error reset is performed at the completion of an emergency mode, the unit repeats the procedures in section (1) above.
- ♦To stop the emergency mode and perform a current-carrying operation after correcting the error, perform a power reset.

2. Communication circuit failure or when some of the heat source units are turned off

This is a temporary operation mode in which the heat source unit that is not in trouble operates when communication circuit failure occurs or when some of the heat source units are turned off.

(1) Starting the emergency operation (When the OC is in trouble)

- 1) When an error occurs, the error source and the error code appear on the display on the remote controller.
- 2) Reset the error via the remote controller to start an emergency operation.

Precautions before servicing the unit

- ♦When the OC is in trouble, the OS temporarily takes over the OC's function and performs an emergency operation. When this happens, the indoor unit connection information are changed.
- ♦In a system that has a billing function, a message indicating that the billing system information has an error may appear on the TG-2000A. Even if this message appears, do not change (or set) the refrigerant system information on the TG-2000A. After the completion of an emergency operation, the correct connection information will be restored.

(2) Starting the emergency operation (When the OS is in trouble)

- 1) A communication error occurs. -> An emergency operation starts in approximately six minutes.

Error codes that permit an emergency operation (Applicable to both OC and OS)

Trouble source	Error codes that permit an emergency operation	Error code description
Circuit board failure or the power to the heat source units is off	6607	No acknowledgement error
	6608	No response error

Emergency operation pattern (2 heat source units)

		OC failure pattern	OS failure pattern
OC		Trouble	Normal
OS		Normal	Trouble
Emergency operation	Cooling	Permitted	Permitted
	Heating	Permitted	Permitted
Maximum total capacity of indoor units (Note 1)		Capacity that matches the total capacity of the operable heat source units	

(3) Ending the emergency operation

When communication is restored, the emergency mode is cancelled, and the units go into the normal operation mode.

-14- Control Method <PQRY only>

The control system configuration for the PQRY models is shown in the chart below.

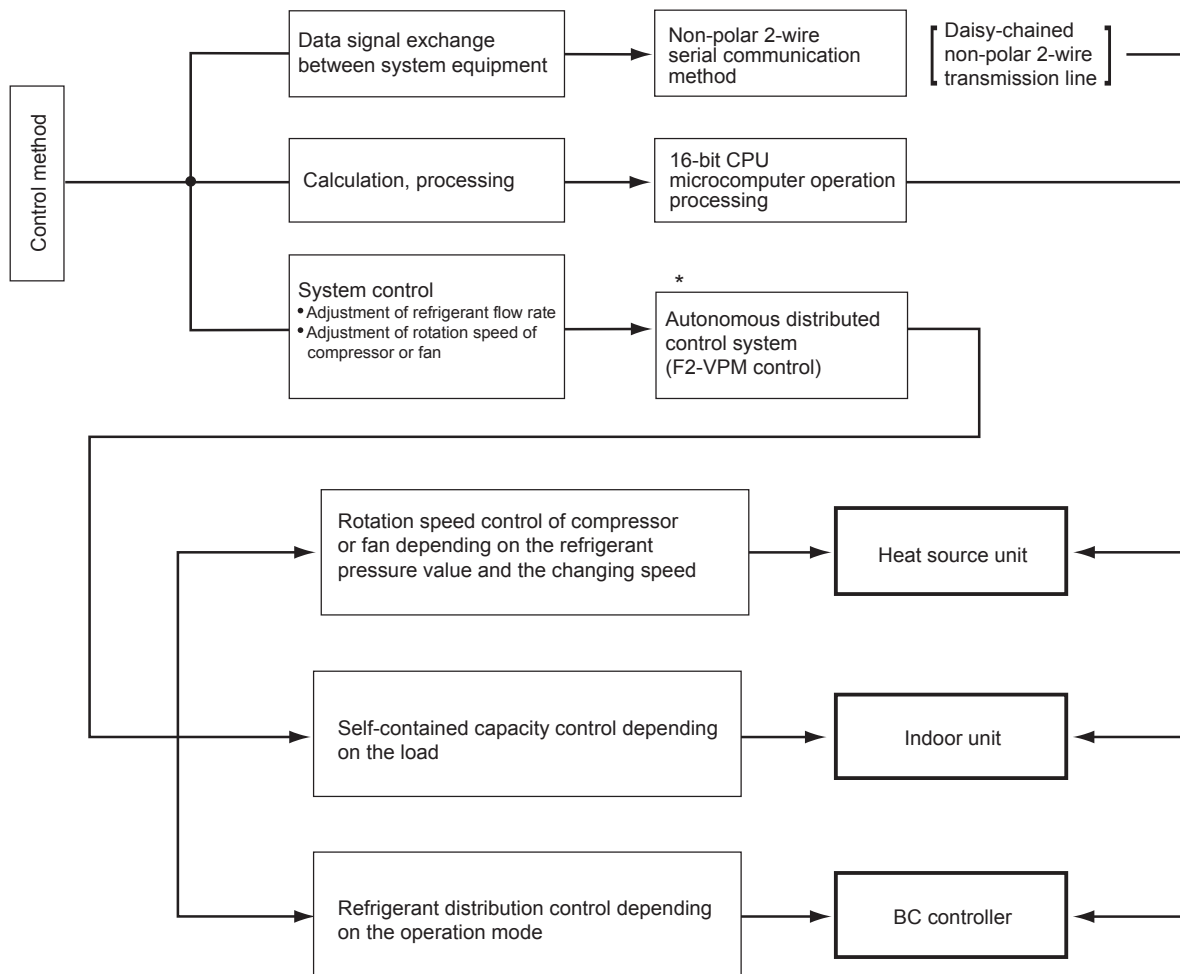

Autonomous distributed control system : A system that consists of three independent sub control systems, instead of a single centralized control system, that work together to maintain the overall control of the entire system.

-15- Cooling/heating Circuit Control and General Function of System Equipment

Operation status	Schematic diagram of refrigerant circuit (— Gas - - - Two-phase = Liquid)	Schematic diagram of refrigerating cycle
Cooling only		
Cooling main		
Heating only		
Heating main		

-16- Operation Mode <PQHY>**(1) Indoor unit operation mode**

The operation mode can be selected from the following 5 modes using the remote controller.

1	Cooling mode
2	Heating mode
3	Dry mode
4	Fan mode
5	Stopped mode

(2) Heat source unit operation mode

1	Cooling mode	All indoor units in operation are in cooling mode.
2	Heating mode	All indoor units in operation are in heating mode.
3	Stopped mode	All indoor units are in fan mode or stopping mode.

Note

When the heat source unit is performing a cooling operation, the operation mode of the connected indoor units that are not in the cooling mode (Stopped, Fan, Thermo-OFF) cannot be changed to heating from the remote controller. If this attempt is made, "Heating" will flash on the remote controller. The opposite is true when the heat source unit is performing a heating operation. (The first selection has the priority.)

-17- Operation Mode <PQRY>

(1) Indoor unit operation mode

The operation mode can be selected from the following 6 modes using the remote controller.

1	Cooling mode
2	Heating mode
3	Dry mode
4	Automatic cooling/heating mode
5	Fan mode
6	Stopping mode

(2) Heat source unit operation mode

1	Cooling only mode	All indoor units in operation are in cooling mode.
2	Heating only mode	All indoor units in operation are in heating mode.
3	Cooling main mode	Coexistence of units in cooling and heating modes.
4	Heating main mode	Coexistence of units in cooling and heating modes.
5	Stopping mode	All indoor units are in fan mode or stopping mode.

Note

When units in cooling and heating coexist, the operation mode (cooling main mode or heating main mode) will be determined by the heat source unit, based on the refrigerant pressure and speed variation data.

(3) Operation pattern for automatic cooling/heating mode

When the automatic cooling/heating mode is selected from remote controller functions, the indoor temperature will be detected in pattern as shown in the figure below, and the operation mode (cooling or heating) will automatically be selected.

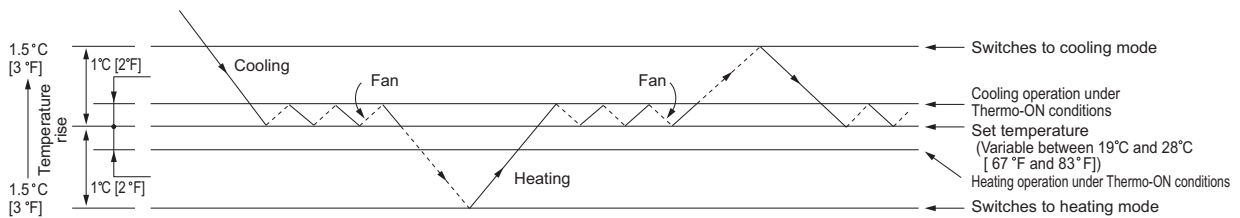

(4) Relationship between the operation mode and the load capacity (kW) (within a system)

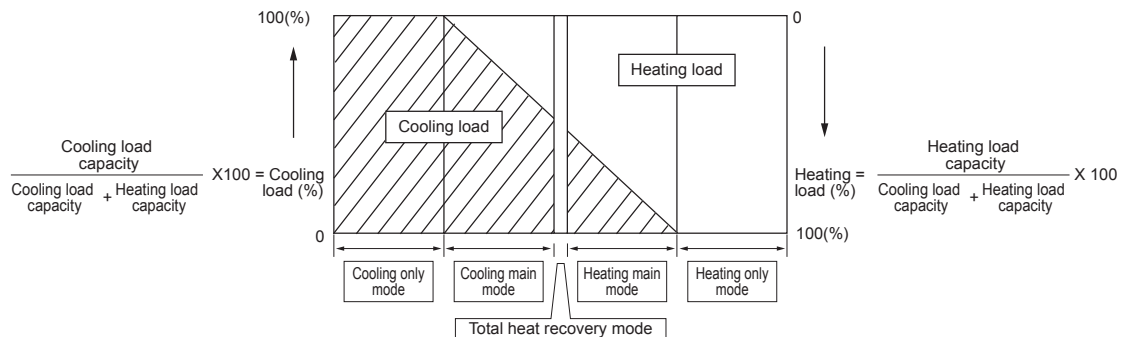

-18- DEMAND Control

Cooling/heating operation can be prohibited (Thermo-OFF) by an external input to the heat source units.

Note

When DIP SW6-8 is set to ON, the 4-step DEMAND control is enabled.

Eight-step demand control is possible in the system with two heat source units.

Twelve-step demand control is possible in the system with three heat source units.

Refer to Chapter II [3] 2.(7) "Various types of control using input-output signal connector on the heat source unit (various connection options)" for details.(page 26)

[3] Controlling BC Controller

1. Control of SV■A, SV■B, and SV■C

SV ■A, SV ■B, and SV ■C turn on or off depending on the operation mode of the branch.

		Mode			
		Cooling	Heating	Stopped	Defrost
Port	SV■A	ON	OFF	OFF	OFF
	SV■B	OFF	ON	OFF	OFF
	SV■C	ON	OFF	OFF	OFF

2. Control of SVM1, SVM1b

SVM turns on or off depending on the operation mode.

Operation mode	Cooling only	Cooling main	Heating only	Heating main	Defrost	Stopped
SVM1,1b	ON	Pressure differential control ^{*1}	OFF	OFF	ON	OFF

*1. Pressure differential control: The detected differential pressure (PS1 and PS3) is controlled every minute so as to be within a certain range.

3. Control of LEV■

LEV ■ opening (s) is controlled as follows depending on the operation mode.

	Operation mode	Cooling only	Cooling main	Heating only	Heating main	Defrost	Stopped
G,GA,HA type	LEV1	2000	Liquid level control ^{*1} differential control ^{*2}	110	110 ^{*3}	2000	1200
	LEV2 (only GA type)						
	LEV3	Superheat control ^{*4}		Pressure differential control ^{*2}	Pressure differential control ^{*2}	G:1000 GA,HA:2000	60
GB,HB type	LEV3	Superheat control ^{*4}	Superheat control ^{*4}	60	60	60	60

*1. Liquid level control: The liquid level detected by the liquid inlet temperature (TH11 sensor) is controlled so as to be within a certain range.

*2. Pressure differential control: The detected differential pressure (PS1 and PS3) is controlled every minute so as to be within a certain range.

*3. Can be 110 or more due to pressure rise on the liquid side (PS1).

*4. Superheat control: The amount of superheat that is calculated on the bypass inlet and outlet temperature (G, GA,HA:TH12,TH15, GB, HB: TH12, TH15) is controlled every minute so as to be within a certain range.

4. Control of SVM2, SVM2b

Operation mode	Cooling only	Cooling main	Heating only	Heating main	Defrost	Stopped
SVM2,2b	OFF	OFF	Pressure differential control ^{*1}	Pressure differential control ^{*1}	OFF	OFF

*1. Pressure differential control: The detected differential pressure (PS1 and PS3) is controlled every minute so as to be within a certain range.

[4] Operation Flow Chart

1. Mode determination flowchart <PQHY>

(1) Indoor unit (cooling, heating, dry, fan mode)

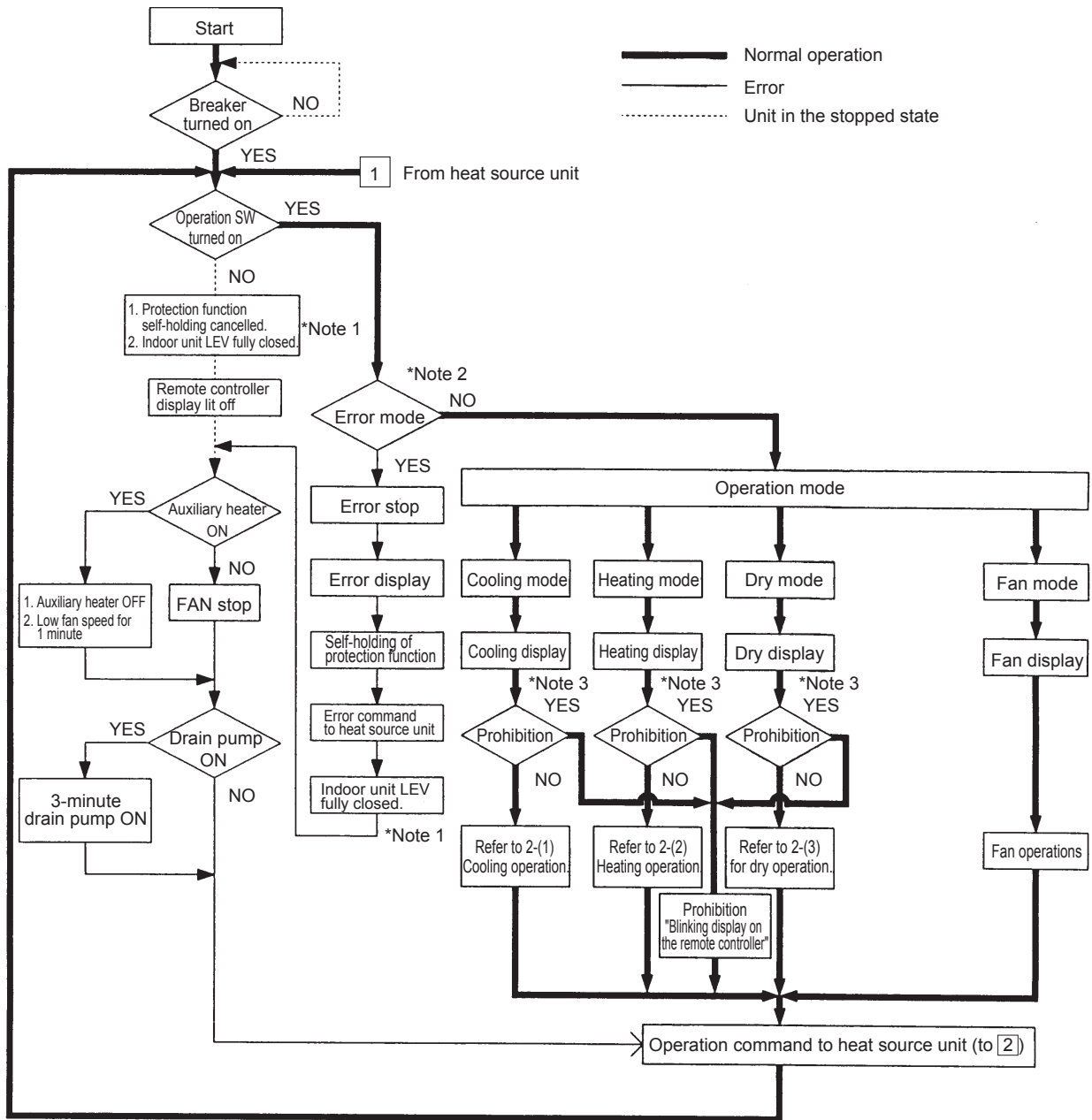

*Note 1. Indoor unit LEV fully closed : Opening 41.

*Note 2. The system may go into the error mode on either the indoor unit or the heat source unit side. If some of the indoor units are experiencing a problem (except water leakage), only those indoor units that are experiencing the problems will stop. If the heat source unit is experiencing a problem, all connected indoor units will stop.

*Note 3. The operation will be prohibited when the set cooling/heating mode is different from that of the heat source unit.

(2) Heat source unit (cooling and heating modes)

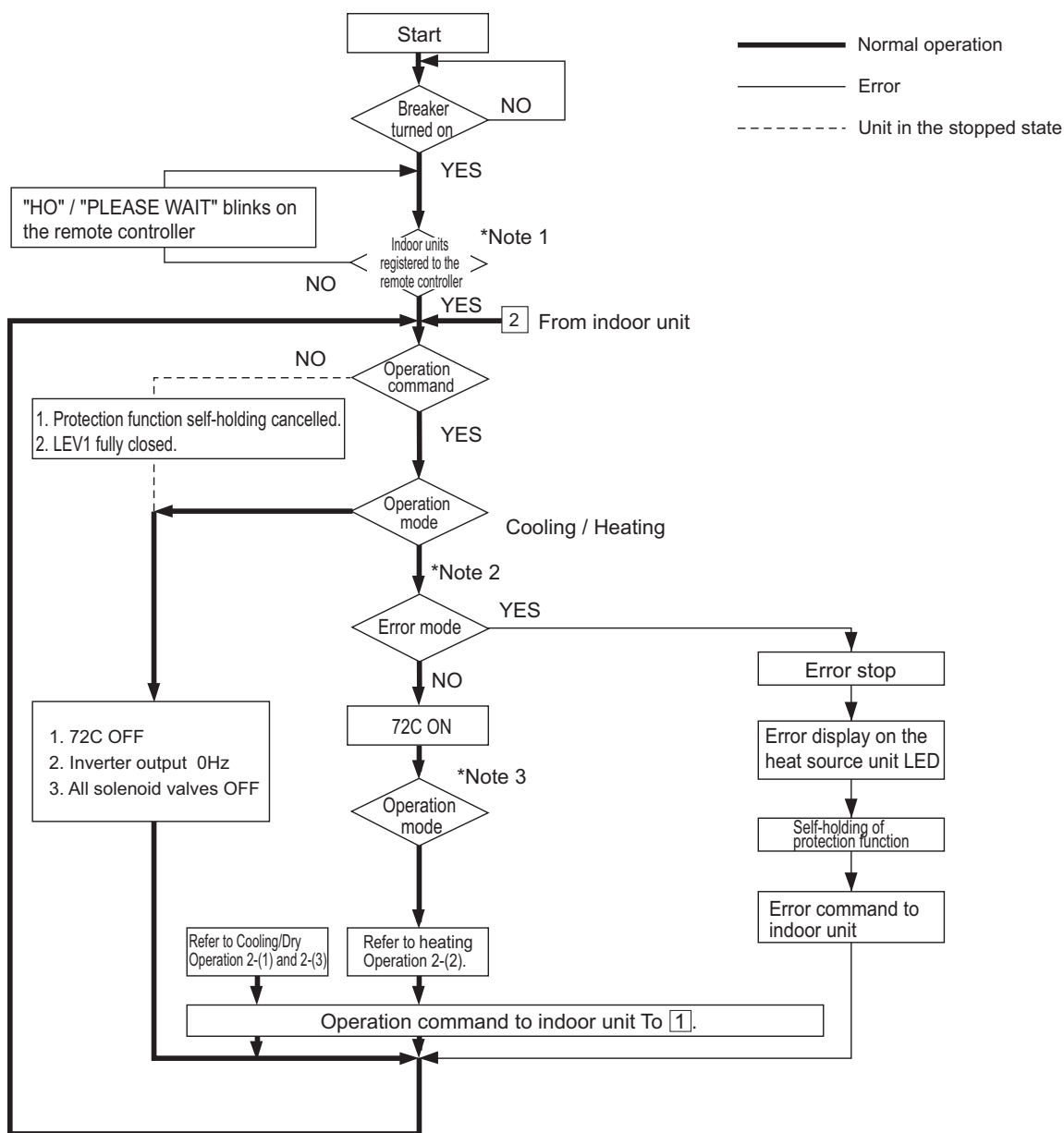

- *Note 1. For about 3 minutes after power on, search for the indoor unit address, for the remote controller address, and for the group information will start. During this, "HO" / "PLEASE WAIT" blinks on the display of the remote controller. When the indoor unit to be controlled by the remote controller is missing, "HO" / "PLEASE WAIT" keeps blinking on the display of the remote controller even after 3 or more minutes after power on.
- *Note 2. The system may go into the error mode on either the indoor unit or the heat source unit side. The heat source unit stops only when all of the connected indoor units are experiencing problems. The operation of even a single indoor unit will keep the heat source unit running. The error will be indicated on the LED display.
- *Note 3. The heat source unit operates according to the operation mode commanded by the indoor unit. However, when the heat source unit is running a cooling operation, come of the operating indoor units will stop, or the operation of these indoor units will be prohibited even when the indoor unit mode is switched from fan mode to heating mode. This also applies when the heat source unit is running a heating operation.

2. Operations in each mode

(1) Cooling operation

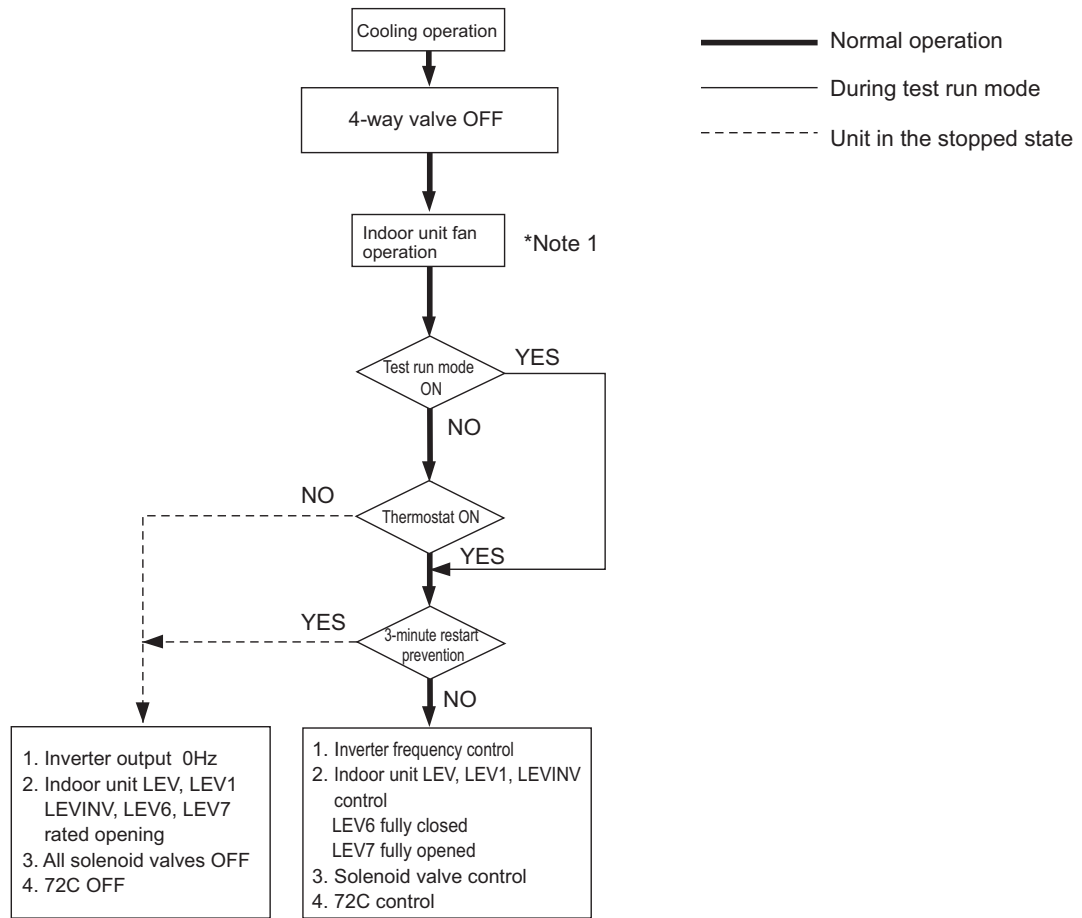

*Note 1. The indoor fan operates at the set notch under cooling mode regardless of the ON/OFF state of the thermostat.

(2) Heating operation

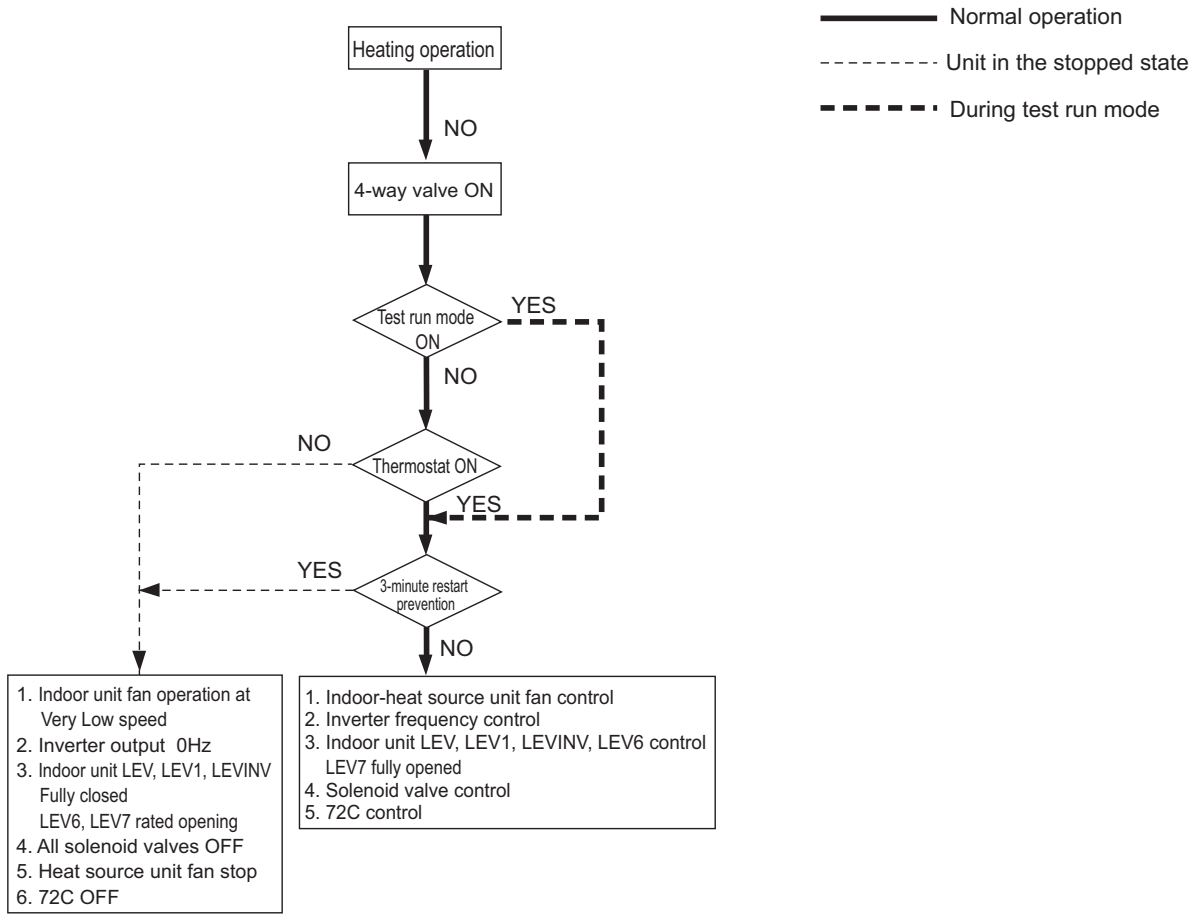

(3) Dry operation

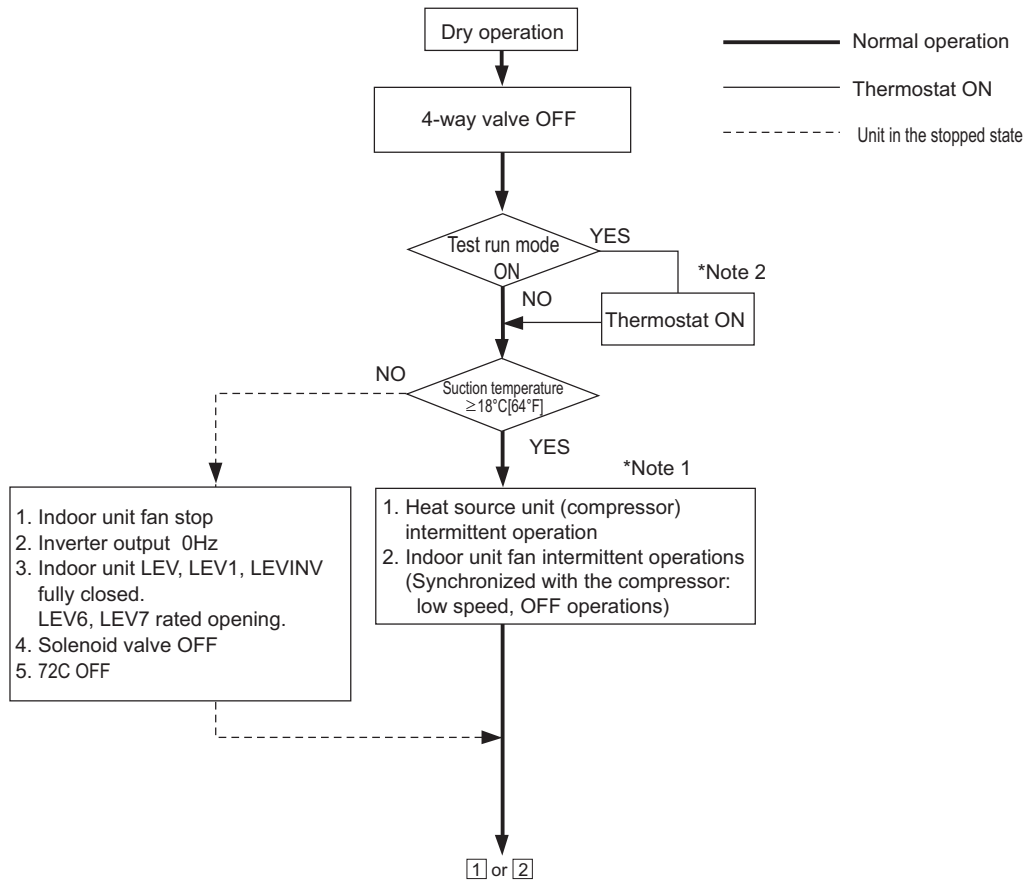

*Note 1. When the indoor unit inlet temperature exceeds 18°C [64°F], the heat source unit (compressor) and the indoor unit fan start the intermittent operation simultaneously. When the indoor unit inlet temperature becomes 18°C [64°F], or less, the fan always runs (at low speed). The heat source unit, the indoor unit, and the solenoid valve operate in the same way as they do in the cooling operation when the compressor is turned on.

*Note 2. Thermostat is always kept on during test run mode, and indoor and heat source unit intermittent operation (ON) time is a little longer than that of normal operation.

1. Mode determination flowchart <PQR>
(1) Indoor unit (cooling, heating, dry, fan mode)

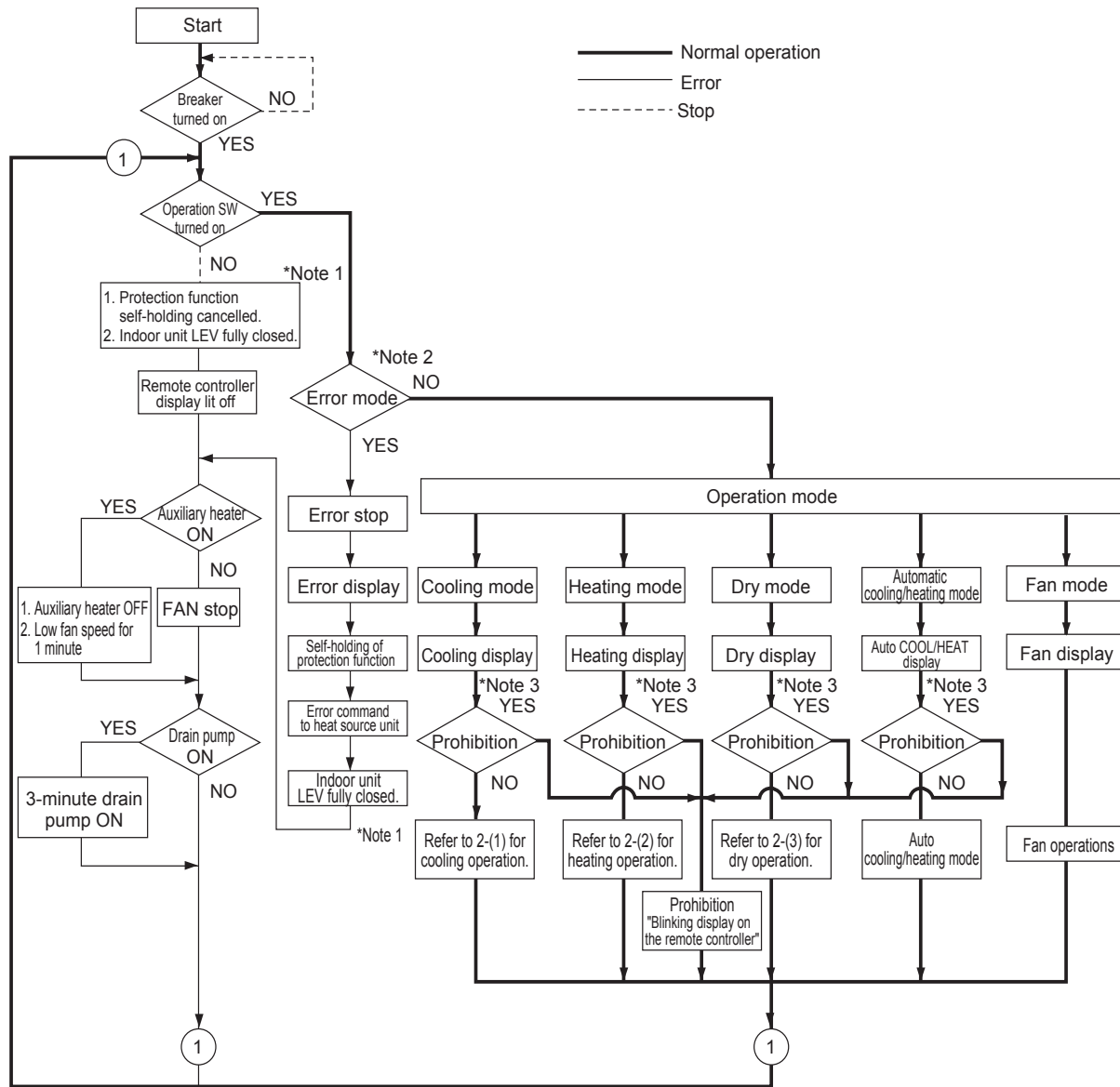

*Note 1. Indoor unit LEV fully closed : Opening 41.

*Note 2. The system may go into the error mode on either the indoor unit side or the BC controller or heat source unit side. If some of the indoor units are experiencing a problem, only those indoor units that are experiencing the problem will stop. If the BC controller or the heat source unit is experiencing a problem, all the connected units will stop.

*Note 3. If multiple indoor units are connected to a port and there is a discrepancy in the operation mode between the indoor unit and the port, the operation will be prohibited. (Operation mode blinks on the remote controller, the Fan stops, indoor unit LEV becomes fully closed.)

(2) Heat source unit (cooling only, heating only, cooling main and heating main modes)

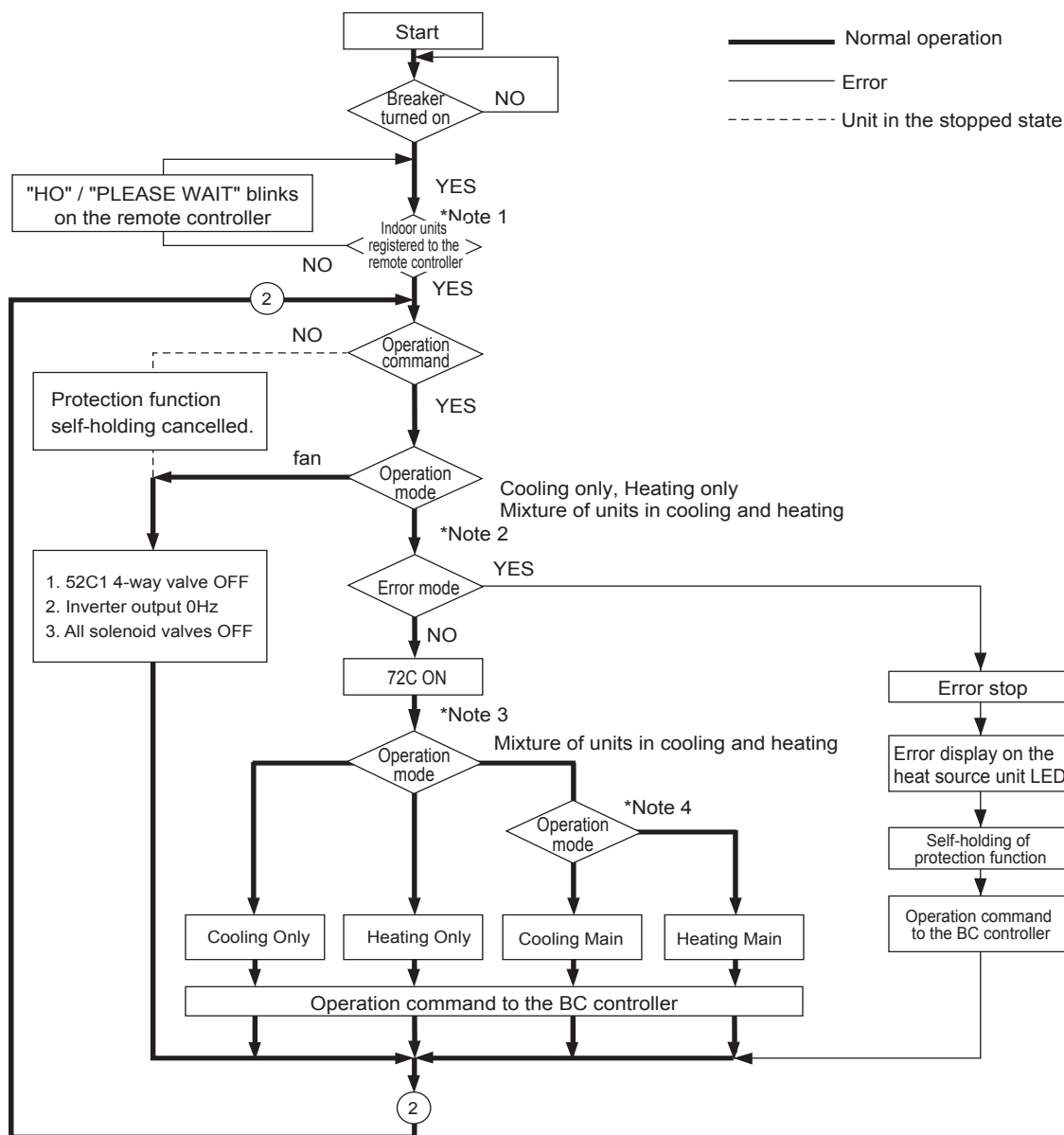

*Note 1. For about 3 minutes after power on, search for the indoor unit address, for the remote controller address, and for the group information will start. During this, "HO"/ "PLEASE WAIT" blinks on the display of the remote controller. When the indoor unit to be controlled by the remote controller is missing, "HO"/ "PLEASE WAIT" keeps blinking on the display of the remote controller even after 3 or more minutes after power on.

*Note 2. The system may go into the error mode on either the indoor unit or the heat source unit side. The heat source unit stops only when all of the connected indoor units are experiencing problems. The operation of even a single indoor unit will keep the heat source unit running. The error will be indicated on the LED display.

*Note 3. The units will follow the operation mode commands from the BC controller

*Note 4. When the operation mode commands from the BC controllers are mixed (both cooling and heating), the actual operation mode is determined by the heat source unit.

(3) BC controller (cooling only, heating only, cooling main and heating main modes)

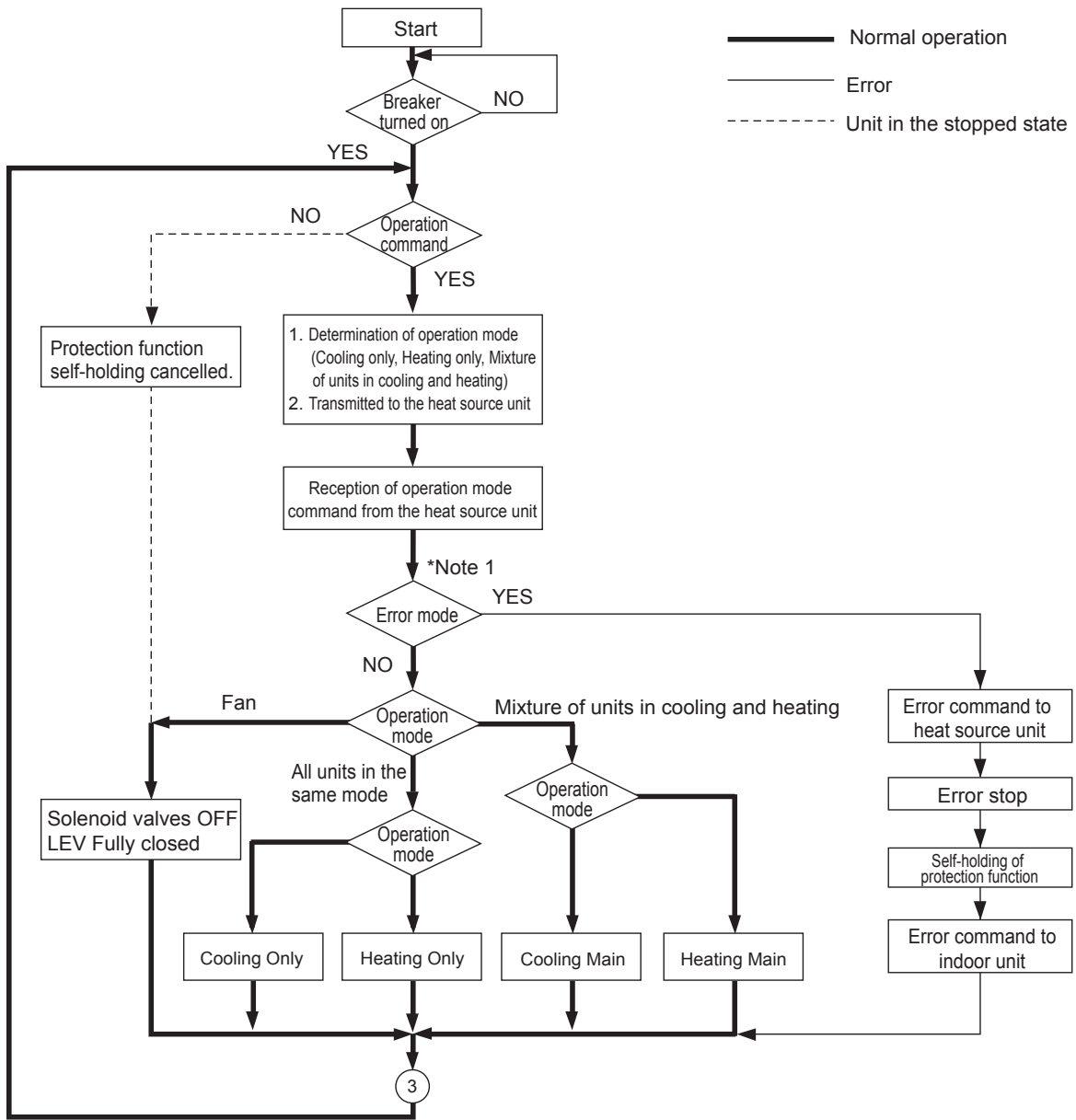

Note 1. The system may go into the error mode on either the indoor unit side or the BC controller or heat source unit side. If some of the indoor units are experiencing a problem, only those indoor units that are experiencing the problem will stop. If the BC controller or the heat source unit is experiencing a problem, all the connected units will stop.

2. Operations in each mode

(1) Cooling operation

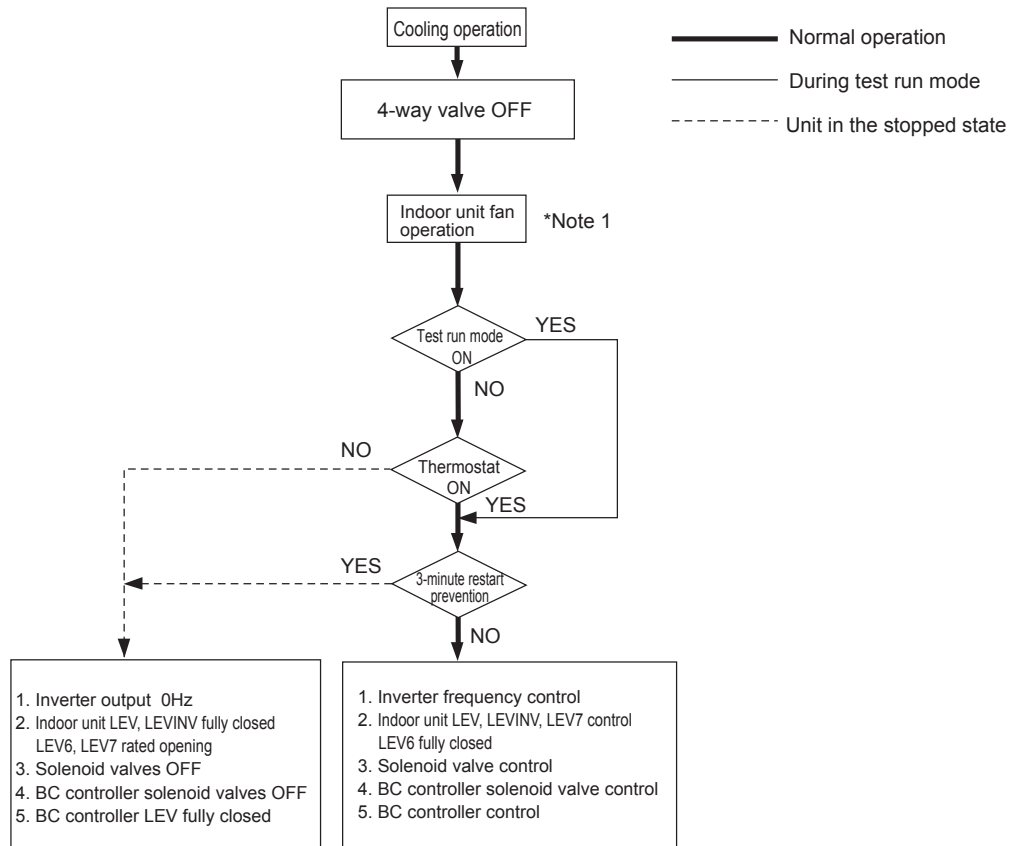

*Note 1. The indoor fan operates at the set notch under cooling mode regardless of the ON/OFF state of the thermostat.

(2) Heating operation

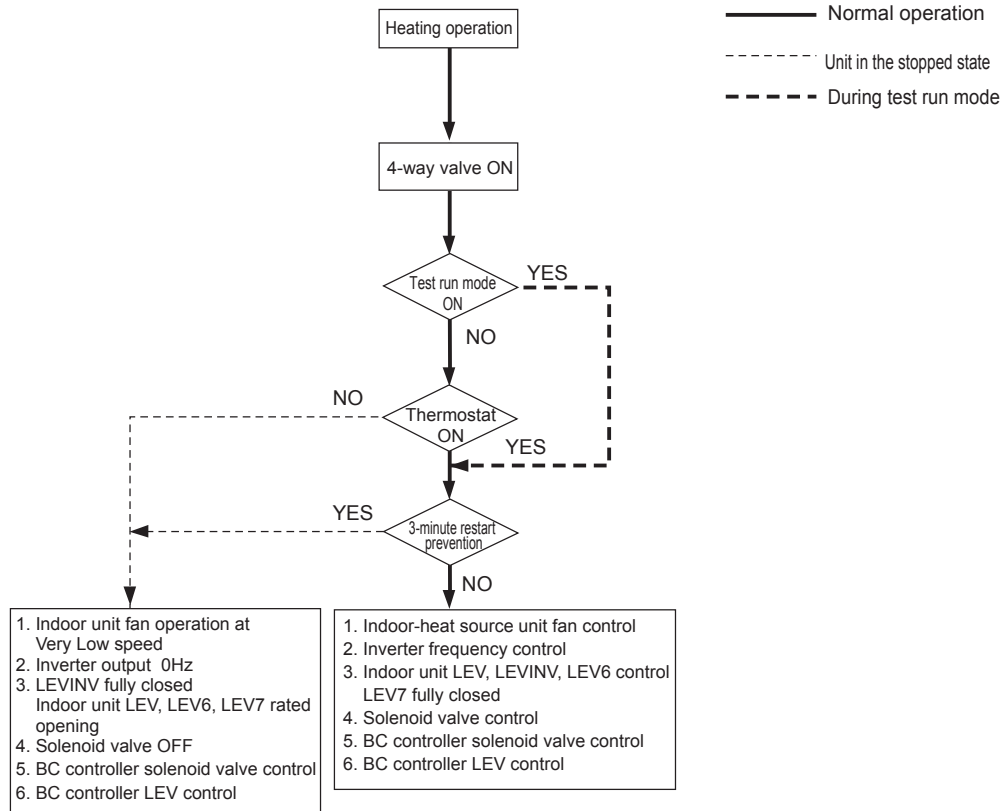

(3) Dry operation

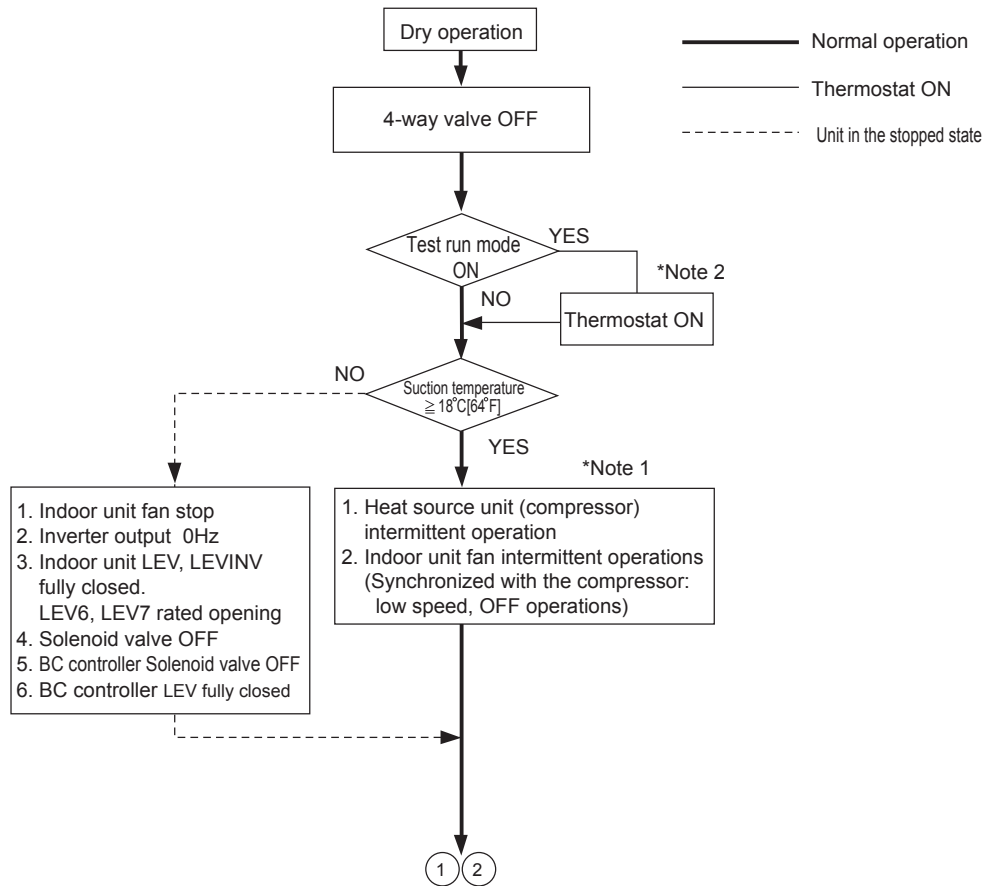

*Note 1. When the indoor unit inlet temperature exceeds 18°C [64°F], the heat source unit (compressor) and the indoor unit fan start the intermittent operation simultaneously. When the indoor unit inlet temperature becomes 18°C [64°F], or less, the fan always runs (at low speed). The heat source unit, the indoor unit, and the solenoid valve operate in the same way as they do in the cooling operation when the compressor is turned on.

*Note 2. Thermostat is always kept on during test run mode, and indoor and heat source unit intermittent operation (ON) time is a little longer than that of normal operation.

VIII Test Run Mode

[1] Items to be checked before a Test Run	195
[2] Test Run Method	196
[3] Operating Characteristic and Refrigerant Amount	199
[4] Adjusting the Refrigerant Amount	199
[5] Refrigerant Amount Adjust Mode	204
[6] The following symptoms are normal.	208
[7] Standard Operation Data (Reference Data)	209



[1] Items to be checked before a Test Run

(1) Check for refrigerant leak and loose cables and connectors.

(2) When opening or closing the front panel of the control box, do not let it come into contact with any of the internal components.

Note

- ♦ Before inspecting the inside of the control box, turn off the power, keep the unit off for at least 10 minutes, and confirm that the capacitor voltage (inverter main circuit) has dropped to 20 VDC or less. (It takes about 10 minutes to discharge electricity after the power supply is turned off.)
- ♦ Control box houses high temperature parts. Be well careful even after turning off the power source.

(3) Measure the insulation resistance between the power supply terminal block and the ground with a 500V megger and make sure it reads at least 1.0Mohm.

Note

- ♦ Do not operate the unit if the insulation resistance is below 1.0Mohm.
- ♦ Do not apply megger voltage to the terminal block for transmission line. Doing so will damage the controller board.
- ♦ The insulation resistance between the power supply terminal block and the ground could go down to close to 1Mohm immediately after installation or when the power is kept off for an extended period of time because of the accumulation of refrigerant in the compressor.
- ♦ If insulation resistance reads at least 1Mohm, by turning on the main power and powering the crankcase heater for at least 12 hours, the refrigerant in the compressor will evaporate and the insulation resistance will go up.
- ♦ Do not measure the insulation resistance of the terminal block for transmission line for the unit remote controller.

(4) When the power is turned on, the compressor is energized even while it is not operating.

Note

- ♦ Before turning on the power, disconnect all power supply wires from the compressor terminal block, and measure the insulation resistance of the compressor.
- ♦ Check the compressor for a ground fault. If the insulation resistance is 1.0 MΩ or below, connect all power supply wires to the compressor and turn on the power to the heat source unit. (The liquid refrigerant in the compressor will evaporate by energizing the compressor.)

(5) Check that the valve on the gas pipe and liquid pipe are fully open.

Note

Securely tighten the cap.

(6) Check the phase sequence and the voltage of the power supply.

When the voltage is out of the $\pm 10\%$ range, or when the phase voltage difference is more than 2%, please discuss the countermeasure with the customer.

(7) [When a transmission booster is connected]

Turn on the transmission booster before turning on the heat source units.

Note

- ♦ If the heat source units are turned on first, the connection information for the refrigerant circuit may not be properly recognized.
- ♦ In case the heat source units are turned on before the transmission booster is turned on, perform a power reset on the heat source units after turning on the power booster.

(8) Turn on the main power to the unit at least 12 hours before test run to power the crankcase heater.

Note

Insufficient powering time may result in compressor damage.

(9) When a power supply unit is connected to the transmission line for centralized control, perform a test run with the power supply unit being energized. Leave the power jumper connector on CN41 as it is (factory setting).

*Includes the cases where power is supplied to the transmission line from a system controller with a power-supply function

[2] Test Run Method

1. MA Remote Controller (PAR-30MAAU)

(1) Remote controller button functions

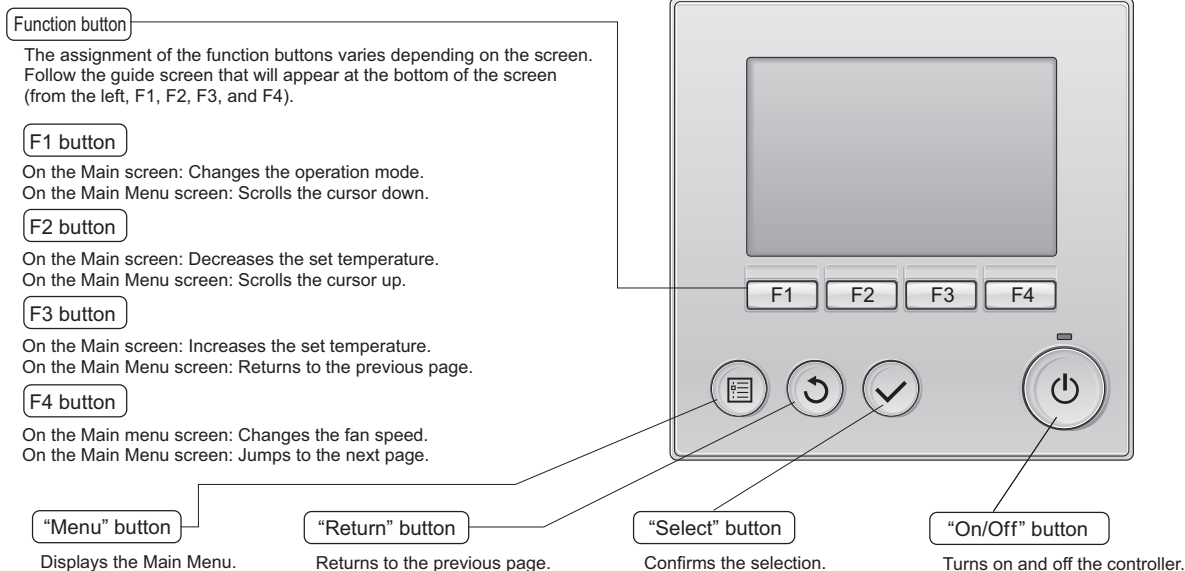

(2) Operation procedures

Step 1: Turn on the main power at least 12 hours before starting operation.

The green power indicator and "Please Wait" will blink on the remote controller for up to five minutes. While they are blinking, remote controller will not respond to button pressing. Wait until "Please Wait" goes off the screen.

Step 2: Set the remote controller to the "Test run" mode.

- 1 On the Service Menu screen, select "Test run" and press the button.
- 2 The test run menu will appear. Select "Test run" and press the button. Test run will begin, and the test run screen will appear.
- 3 It may take up to 15 minutes to detect a system error. (*Keep all the systems simultaneously operating for a minimum of 15 minutes.)

Step 3: Check the supply air temperatures and the auto vane functions.

- 1 Press the F1 button to change the operation mode.
Cooling: Check that the supply air is cold.
Heating: Check that the supply air is warm.
- 2 Press the button to bring up the screen to change the airflow direction, and check the auto vane with the F1 and F2 buttons. Press the button to return to the "Test run" screen.



Step 4: Ending the test run

- 1 Press the button to end the test run. (The screen will return to the Test run menu.)

(3) Entering the maintenance information

occurs.

Step 1: Switching the remote controller screen to "Maintenance information" (Requires the maintenance password. This screen is not accessible while the controller is under centralized control.)

- 1 On the Service Menu screen, select "Input maintenance info." and press the  button.
- 2 Select "Model name input" and press the  button.

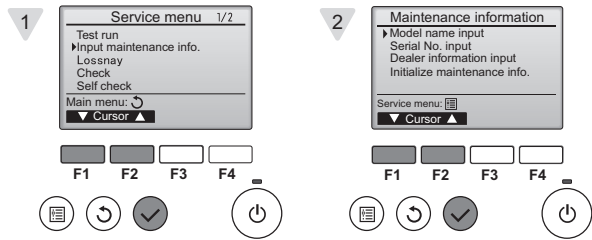

Step 2: Selecting the heat source unit address and indoor unit address information to be registered

- 1 Select the address to be registered, using the F1 and F2 buttons, and then press the  button.
 - Address: 0-255

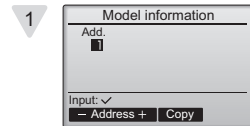

Step 3: Registering the model name

- 1 Enter the model name. The character string can be up to 18 characters in length.
 - Move the cursor left with the F1 button, and right with the F2 button.
 - Select a character with the F3 and F4 buttons.
 - Press the  button when done entering characters. The screen will return to the one shown in Step 2.

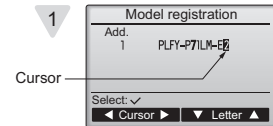

Repeat Steps 2 and 3 until all the model names of the units at the selected addresses have been entered. To change the address, press the  button on the screen shown in Step 3 to return to the screen shown in Step 2, and then change the address. After changing the address, enter the model name.

Tips: the model name information of the unit at a given address can be copied and pasted to another unit at a different address.



- Press the F3 button in Step 2 to copy the model name information of the unit at the selected address.
- Press the F4 button in Step 2 to overwrite the model name information of the unit at the selected address.

Step 4: Registering the serial number

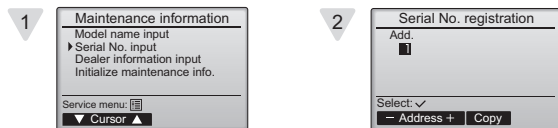
- 1 Select "Serial No. input" in Step 1-2 above, and then press the  button.
- 2 Register the serial number by following steps 2 and 3 above. The serial number can be up to 8 characters in length.



Step 5: Entering your dealer's phone number



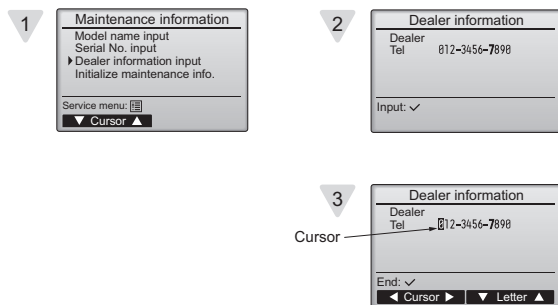

- 1 Select "Dealer information input" on the Maintenance information screen, and press the  button.
- 2 Press the  button when "Dealer information" appears.
- 3 Enter your dealer's telephone number. Telephone number can be up to 13 characters.
 - Move the cursor left with the F1 button, and right with the F2 button.
 - Select a character with the F3 and F4 buttons.
 - Press the  button when done entering characters.

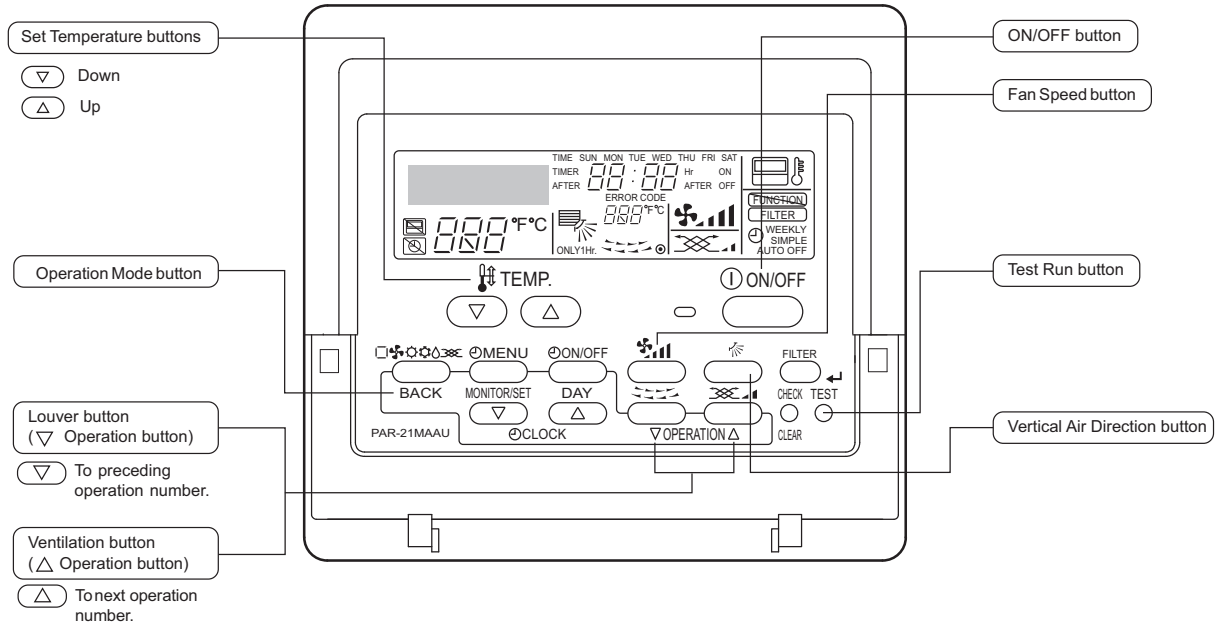

2. MA Remote Controller (PAR-21MAAU)

The figure shows an MA remote controller (PAR-21MAAU).



Operation procedures	
Turn on the main power.	→ "PLEASE WAIT" appears on the LCD for up to five minutes. Leave the power on for 12 hours. (Energize the belt heater.)
Press the Test button twice.	→ Operation mode display "TEST RUN" and OPERATION MODE are displayed alternately.
Press the Operation Mode button. 	→ Make sure that the air is blowing out.
Switch to cooling (or heating) operation by pressing the Operation Mode button. 	→ Make sure that cold (or warm) air blows out. On the same refrigerant system, make the operation mode the same.
Press the Fan Speed button. 	→ Make sure that the fan speed changes with each pressing of the button.
Change the air flow direction by pressing the Vertical Air Direction button  or the Louver button. 	→ Make sure that the air flow direction changes with each pressing of the button.
Confirm the operation of all interlocked equipment, such as ventilation equipment.	
Cancel the test run by pressing the ON/OFF button.	→ Stop
<p>Note 1: Refer to the following pages if an error code appears on the remote controller or when the unit malfunctions.</p> <p>2: The OFF timer will automatically stop the test run after 2 hours.</p> <p>3: The remaining time for the test run will be displayed in the time display during test run.</p> <p>4: The temperature of the liquid pipe on the indoor unit will be displayed in the room temperature display window on the remote controller during test run.</p> <p>5: On some models, "NOT AVAILABLE" may appear on the display when the Vane Control button is pressed. This is normal.</p> <p>6: If an external input is connected, perform a test run using the external input signal.</p> <p>7: Test run all systems for at least 15 minutes to detect possible system errors.</p>	

[3] Operating Characteristic and Refrigerant Amount

It is important to have a clear understanding of the characteristics of refrigerant and the operating characteristics of air conditioners before attempting to adjust the refrigerant amount in a given system.

1. Operating characteristic and refrigerant amount

The following table shows items of particular importance.

- 1) During cooling operation, the amount of refrigerant in the accumulator is the smallest when all indoor units are in operation.
- 2) During heating operation, the amount of refrigerant in the accumulator is the largest when all indoor units are in operation.
- 3) General tendency of discharge temperature
 - ♦ Discharge temperature tends to rise when the system is short on refrigerant.
 - ♦ Changing the amount of refrigerant in the system while there is refrigerant in the accumulator has little effect on the discharge temperature.
 - ♦ The higher the pressure, the more likely it is for the discharge temperature to rise.
 - ♦ The lower the pressure, the more likely it is for the discharge temperature to rise.
- 4) When the amount of refrigerant in the system is adequate, the compressor shell temperature is 10 to 60°C [18 to 108°F] higher than the low pressure saturation temperature (Te).
 - > If the temperature difference between the compressor shell temperature and low pressure saturation temperature (Te) is smaller than 5°C [9°F], an overcharging of refrigerant is suspected.

[4] Adjusting the Refrigerant Amount

1. Symptoms

Overcharging or undercharging of refrigerant can cause the following symptoms:

Before attempting to adjust the amount of refrigerant in the system, thoroughly check the operating conditions of the system. Then, adjust the refrigerant amount by running the unit in the refrigerant amount adjust mode.

The system comes to an abnormal stop, displaying 1500 (overcharged refrigerant) on the controller.	Overcharged refrigerant
The operating frequency does not reach the set frequency, and there is a problem with performance.	Insufficient refrigerant amount
The system comes to an abnormal stop, displaying 1102 (abnormal discharge temperature) on the controller.	

2. Amount of refrigerant

(1) To be checked during operation

Operate all indoor units in either cooling-only or heating-only mode, and check such items as discharge temperature, subcooling, low pressure, suction temperature, and shell bottom temperature to estimate the amount of refrigerant in the system.

Symptoms	Conclusion
Discharge temperature is high. (Normal discharge temperature is below 95°C [203°F].)	Slightly undercharged refrigerant
Low pressure is unusually low.	
Suction superheat is large. (Normal suction superheat is less than 20°C [36°F].)	
Compressor shell bottom temperature is high. (The difference between the compressor shell bottom temperature and low pressure saturation temperature (Te) is greater than 60°C [108°F].)	Slightly overcharged refrigerant
Discharge superheat is small. (Normal discharge superheat is greater than 10°C [18°F].)	
Compressor shell bottom temperature is low. (The difference between the compressor shell bottom temperature and low pressure saturation temperature (Te) is less than 5°C [9°F].)	

3. Amount of refrigerant to be added<PQHY>

The amount of refrigerant that is shown in the table below is factory-charged to the heat source units.
The amount necessary for extended pipe (field piping) is not included and must be added on site.

Heat source unit model	P72	P96	P120	P144	P168	P192	P216	P240
Amount of pre-charged refrigerant in the heat source unit (kg)	5.0	5.0	5.0	6.0	6.0	6.0	11.7	11.7
Amount of pre-charged refrigerant in the heat source unit [lbs]	11.0	11.0	11.0	13.2	13.2	13.2	25.8	25.8

(1) Calculation formula

The amount of refrigerant to be added depends on the size and the length of field piping. (unit in m[ft])

Amount of added refrigerant (kg) = $(0.29 \times L_1) + (0.2 \times L_2) + (0.12 \times L_3) + (0.06 \times L_4) + (0.024 \times L_5) + \alpha$
 Amount of added refrigerant (oz) = $(3.12 \times L_1') + (2.15 \times L_2') + (1.29 \times L_3') + (0.65 \times L_4') + (0.26 \times L_5') + \alpha'$

- | | |
|--|--|
| <p>L_1 : Length of $\varnothing 19.05$ [3/4"] liquid pipe (m)
 L_2 : Length of $\varnothing 15.88$ [5/8"] liquid pipe (m)
 L_3 : Length of $\varnothing 12.7$ [1/2"] liquid pipe (m)
 L_4 : Length of $\varnothing 9.52$ [3/8"] liquid pipe (m)
 L_5 : Length of $\varnothing 6.35$ [1/4"] liquid pipe (m)
 α, α' : Refer to the table below.</p> | <p>L_1' : Length of $\varnothing 19.05$ [3/4"] liquid pipe [ft]
 L_2' : Length of $\varnothing 15.88$ [5/8"] liquid pipe [ft]
 L_3' : Length of $\varnothing 12.7$ [1/2"] liquid pipe [ft]
 L_4' : Length of $\varnothing 9.52$ [3/8"] liquid pipe [ft]
 L_5' : Length of $\varnothing 6.35$ [1/4"] liquid pipe [ft]</p> |
|--|--|

Total capacity of connected indoor units	α (kg)	α' (oz)
- 27	2.0	71
28 - 54	2.5	89
55 - 126	3.0	106
127 - 144	3.5	124
145 - 180	4.5	159
181 - 234	5.0	177
235 - 273	6.0	212
274 - 307	8.0	283
308 - 342	9.0	318
343 - 411	10.0	353
412 - 480	12.0	424
481 -	14.0	494

*When connecting PLFY-P08NBMU-E2, add 0.3 kg (10.6 oz) of refrigerant per indoor unit

*When connecting PLFY-EP08NEMU-E, add 0.3 kg (10.6 oz) of refrigerant per indoor unit

Round up the calculation result to the nearest 0.1kg. (Example: 18.04kg to 18.1kg)

Round up the calculation result in increments of 4oz (0.1kg) or round it up to the nearest 1oz. (Example: 178.21oz to 179oz)

(2) Example: PQHY-P144TSHMU-A1/YSHMU-A1

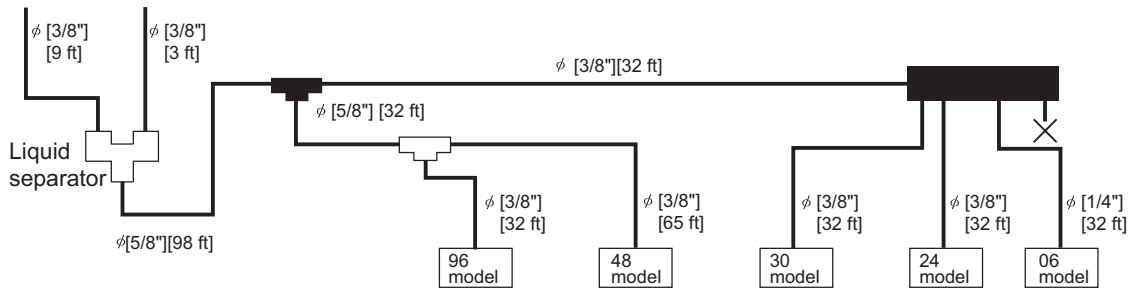
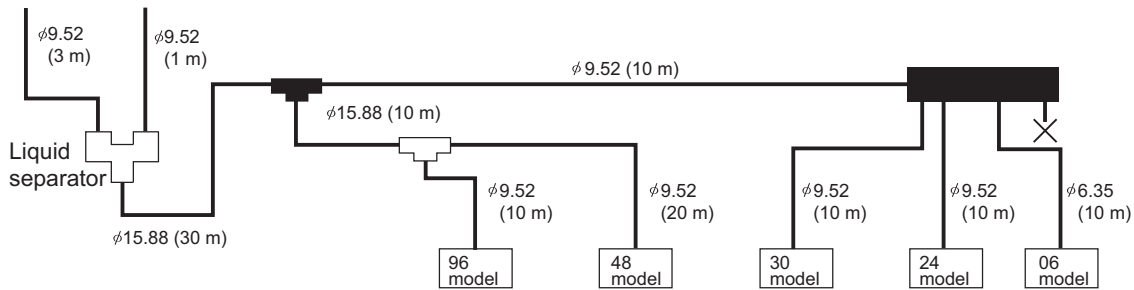

(3) Sample calculation

All the pipes in the figure are liquid pipes.

$\phi 15.88 : 30 \text{ m} + 10 \text{ m} = 40 \text{ m}$

$\phi 9.52 : 3 \text{ m} + 1 \text{ m} + 10 \text{ m} + 10 \text{ m} + 20 \text{ m} + 10 \text{ m} + 10 \text{ m} = 64 \text{ m}$

$\phi 6.35 : 10 \text{ m}$

According to the above formula

Amount of refrigerant to be charged (kg) = $(0.2 \times 40) + (0.06 \times 64) + (0.024 \times 10) + 5.0 = 17.08 \text{ kg}$

The calculation result would be 17.08, and it is rounded up to the nearest 0.1.

The final result will be as follows:

Amount of refrigerant to be charged = 17.1 kg



All the pipes in the figure are liquid pipes.

$\phi 5/8" : [98 \text{ ft}] + [32 \text{ ft}] = [130 \text{ ft}]$

$\phi 3/8" : [9 \text{ ft}] + [3 \text{ ft}] + [32 \text{ ft}] + [32 \text{ ft}] + [65 \text{ ft}] + [32 \text{ ft}] + [32 \text{ ft}] = [205 \text{ ft}]$

$\phi 1/4" : [32 \text{ ft}]$

According to the above formula

Amount of refrigerant to be charged (oz) = $(2.15 \times 130) + (0.65 \times 205) + (0.26 \times 32) + 177 = 598.07 \text{ oz}$

The calculation result would be 598.07 oz, and it is rounded up to the nearest 1 oz.

The final result will be as follows:

Amount of refrigerant to be charged = 599 oz



⚠ CAUTION

Charge liquid refrigerant (as opposed to gaseous refrigerant) into the system.

- If gaseous refrigerant is charged into the system, the composition of the refrigerant in the cylinder will change and may result in performance loss.

4. Amount of refrigerant to be added <PQRY>

The amount of refrigerant that is shown in the table below is factory-charged to the heat source units.
The amount necessary for extended pipe (field piping) is not included and must be added on site.

Heat source unit model	P72	P96	P120	P144	P168	P192	P216	P240
Amount of pre-charged refrigerant in the heat source unit (kg)	5.0	5.0	5.0	6.0	6.0	6.0	11.7	11.7
Amount of pre-charged refrigerant in the heat source unit [lbs]	11.0	11.0	11.0	13.2	13.2	13.2	25.8	25.8

(1) Calculation formula

The amount of refrigerant to be added depends on the size and the length of field piping. (unit in m[ft])

$\begin{aligned} \text{Amount of added refrigerant (kg)} &= (0.36 \times L_1) + (0.23 \times L_2) + (0.16 \times L_3) + (0.11 \times L_4) + (0.2 \times L_5) \\ &\quad + (0.12 \times L_6) + (0.06 \times L_7) + (0.024 \times L_8) + \alpha_1 + \alpha_2 + \alpha_3 + \alpha_4 \end{aligned}$ $\begin{aligned} \text{Amount of added refrigerant (oz)} &= (3.88 \times L_1') + (2.48 \times L_2') + (1.73 \times L_3') + (1.19 \times L_4') + (2.16 \times L_5') \\ &\quad + (1.30 \times L_6') + (0.65 \times L_7') + (0.26 \times L_8') + \alpha_1' + \alpha_2' + \alpha_3' + \alpha_4' \end{aligned}$

- | | |
|--|--|
| L_1 : Length of $\varnothing 28.58[1-1/8"]$ high pressure pipe (m) | L_1' : Length of $\varnothing 28.58[1-1/8"]$ high pressure pipe [ft] |
| L_2 : Length of $\varnothing 22.2[7/8"]$ high pressure pipe (m) | L_2' : Length of $\varnothing 22.2[7/8"]$ high pressure pipe [ft] |
| L_3 : Length of $\varnothing 19.05[3/4"]$ high pressure pipe (m) | L_3' : Length of $\varnothing 19.05[3/4"]$ high pressure pipe [ft] |
| L_4 : Length of $\varnothing 15.88[5/8"]$ high pressure pipe (m) | L_4' : Length of $\varnothing 15.88[5/8"]$ high pressure pipe [ft] |
| L_5 : Length of $\varnothing 15.88[5/8"]$ liquid pipe (m) | L_5' : Length of $\varnothing 15.88[5/8"]$ liquid pipe [ft] |
| L_6 : Length of $\varnothing 12.7[1/2"]$ liquid pipe (m) | L_6' : Length of $\varnothing 12.7[1/2"]$ liquid pipe [ft] |
| L_7 : Length of $\varnothing 9.52[3/8"]$ liquid pipe (m) | L_7' : Length of $\varnothing 9.52[3/8"]$ liquid pipe [ft] |
| L_8 : Length of $\varnothing 6.35[1/4"]$ liquid pipe (m) | L_8' : Length of $\varnothing 6.35[1/4"]$ liquid pipe [ft] |
- $\alpha_1, \alpha_2, \alpha_3, \alpha_4, \alpha_1', \alpha_2', \alpha_3', \alpha_4'$: Refer to the table below.

Heat source unit total index	Amount for the BC controllers (main/sub)	
	α_1 (kg)	α_1' (oz)
P72	3.0	106
P96		
P120		
P144		
P168		
P192		
P216		
P240		

BC controller (Main)		
HA TYPE	α_2 (kg)	α_2' (oz)
1	2.0	71

BC controller (sub)		
Total number of BC	α_3 (kg)	α_3' (oz)
1	1.0	35
2	2.0	71

Total capacity of connected indoor units	Amount for the Indoor unit	
	α_4 (kg)	α_4' (oz)
- 27	2.0	71
28 - 54	2.5	89
55 - 126	3.0	106
127 - 144	3.5	124
145 - 180	4.5	159
181 - 234	5.0	177
235 - 273	6.0	212
274 - 307	8.0	283
308 - 342	9.0	318
343 - 411	10.0	353
412 - 480	12.0	424
481 -	14.0	494

*When connecting PLFY-P08NBMU-E2, add 0.3 kg (10.6 oz) of refrigerant per indoor unit

*When connecting PLFY-EP08NEMU-E, add 0.3 kg (10.6 oz) of refrigerant per indoor unit

Round up the calculation result to the nearest 0.1kg. (Example: 18.04kg to 18.1kg)

Round up the calculation result in increments of 4oz (0.1kg) or round it up to the nearest 1oz. (Example: 78.21oz to 79oz)

(2) Example

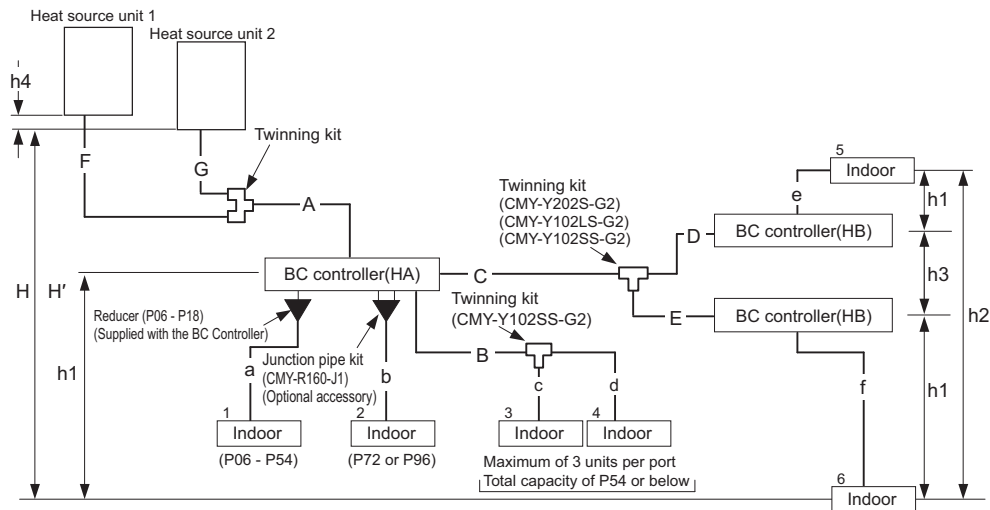

(3) Sample calculation

When	{	Indoor unit1:30 model	A : ϕ 28.58	[1-1/8"]	40m[131ft]	a : ϕ 9.52	[3/8"]	10m[32ft]
		Indoor unit2:96 model	B : ϕ 9.52	[3/8"]	10m[32ft]	b : ϕ 9.52	[3/8"]	5m[16ft]
		Indoor unit3:12 model	C : ϕ 9.52	[3/8"]	20m[65ft]	c : ϕ 6.35	[1/4"]	5m[16ft]
		Indoor unit4:15 model	D : ϕ 9.52	[3/8"]	5m[16ft]	d : ϕ 6.35	[1/4"]	10m[32ft]
		Indoor unit5:12 model	E : ϕ 9.52	[3/8"]	5m[16ft]	e : ϕ 6.35	[1/4"]	5m[16ft]
		Indoor unit6:24 model	F : ϕ 19.05	[3/4"]	3m[9ft]	f : ϕ 9.52	[3/8"]	5m[16ft]
			G : ϕ 19.05	[3/4"]	1m[3ft]			

The aggregate length of each liquid pipe type.

- ϕ 28.58 A = 40m[131ft]
- ϕ 19.05 F+G = 4m[13ft]
- ϕ 9.52 B+C+D+E+a+b+f = 60m[196ft]
- ϕ 6.35 c+d+e = 20m[65ft]

The final result will be as follows:

$$\begin{aligned} \text{Amount of refrigerant to be charged} &= 40 \times 0.36 + 4 \times 0.16 + 60 \times 0.06 + 20 \times 0.024 + 3 + 2 + 2 + 5 \\ &= 31.2\text{kg} \end{aligned}$$

[5] Refrigerant Amount Adjust Mode

1. Procedures <PQHY>

Follow the procedures below to add or extract refrigerant as necessary depending on the operation mode.

When the function switch SW4 No.922 (SW6-10: ON) on the main board on the heat source unit (OC only) is turned to ON, the unit goes into the refrigerant amount adjust mode, and the following sequence is followed.

Note

- 1) SW4-3 on the OS is invalid, and the unit will not go into the refrigerant amount adjust mode.
- 2) Refer to the relevant sections of the manual for how to set SW4 on the control board.(page 160)

Operation

When the unit is in the refrigerant amount adjust mode, the LEV on the indoor unit does not open as fully as it normally does during cooling operation to secure subcooling.

Note

- 1) Adjust the refrigerant amount based on the values of TH4, TH3, TH6, and Tc, following the flowchart below. Check the TH4, TH3, TH6, and Tc values on the OC, OS1, and OS2 by following the flowchart. The TH4, TH3, TH6, and Tc values can be displayed by setting the self-diagnosis switch SW4 (SW6-10: OFF) on the main board on the OC, OS1, and OS2.
- 2) There may be cases when the refrigerant amount may seem adequate for a short while after starting the unit in the refrigerant amount adjust mode but turn out to be inadequate later on (when the refrigerant system stabilizes).

When the amount of refrigerant is truly adequate.

TH3-TH6 on the heat source unit is 5°C [9°F] or above and SH on the indoor unit is between 5 and 15°C [9 and 27°F].

The refrigerant amount may seem adequate at the moment, but may turn out to be inadequate later on.

TH3-TH6 on the heat source unit is 5°C [9°F] or less and SH on the indoor unit is 5°C [9°F] or less.

Wait until the TH3-TH6 reaches 5°C [9°F] or above and the SH of the indoor unit is between 5 and 15°C [9 and 27°F] to determine that the refrigerant amount is adequate.

- 3) High pressure must be at least 2.0MPa[290psi] to enable a proper adjustment of refrigerant amount to be made.
- 4) Refrigerant amount adjust mode automatically ends 90 minutes after beginning. When this happens, by turning off the SW4 No.922 (SW6-10: ON) and turning them back on, the unit will go back into the refrigerant amount adjust mode.

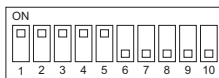
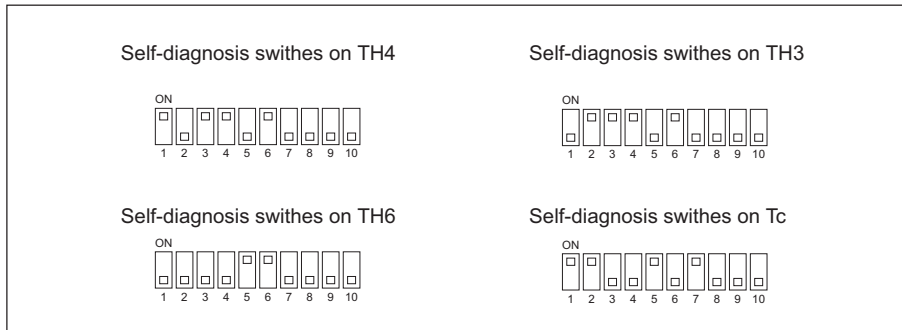

The figure at left shows that the switches 1 through 5 are set to ON and 6 through 10 are set to OFF.

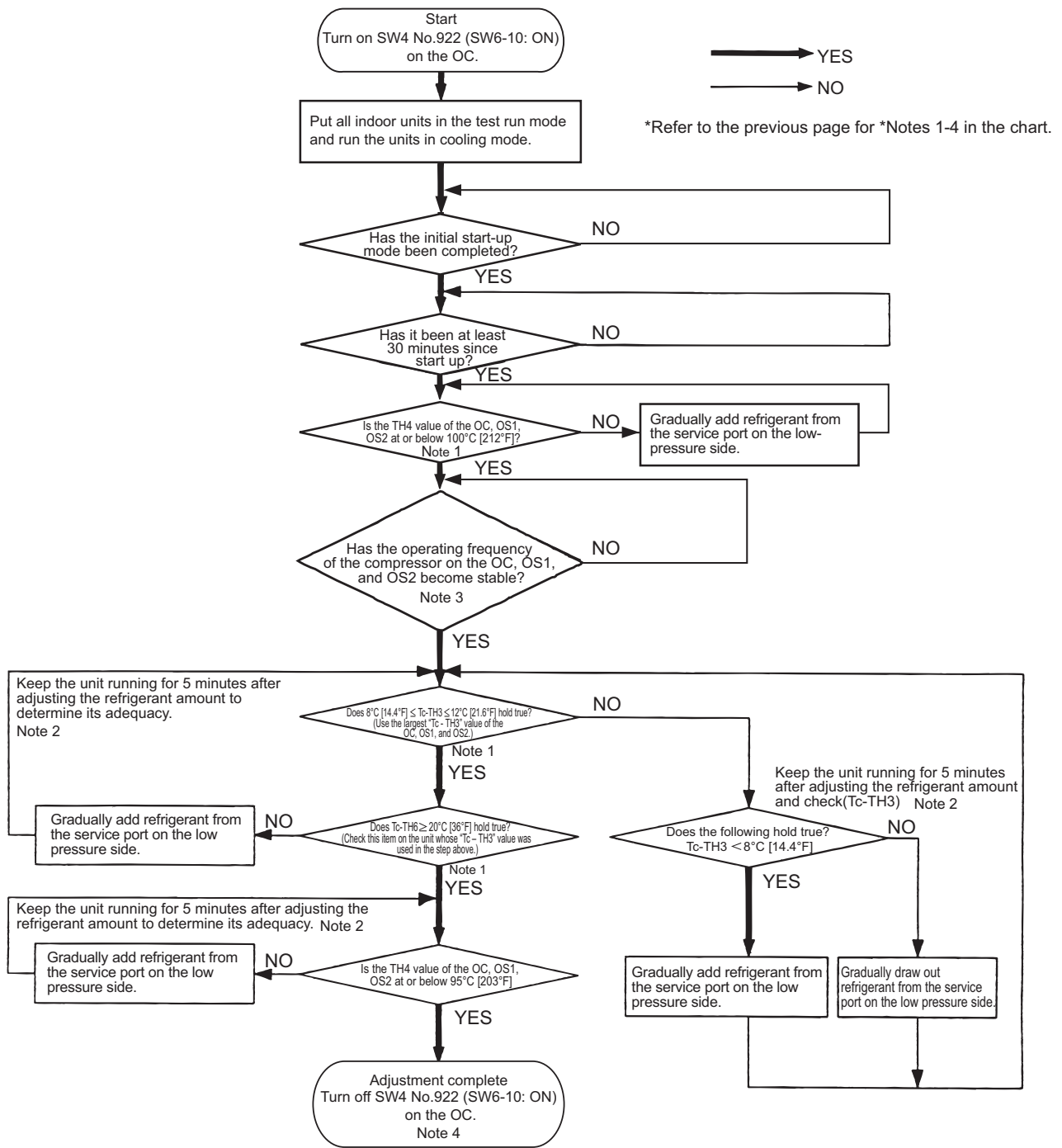

CAUTION
Do not release the extracted refrigerant into the air.

CAUTION
Charge liquid refrigerant (as opposed to gaseous refrigerant) into the system.
• If gaseous refrigerant is charged into the system, the composition of the refrigerant in the cylinder will change and may result in performance loss.

2. Procedures <PQRY>

Follow the procedures below to add or extract refrigerant as necessary depending on the operation mode.

When the function switch SW4 No.922 (SW6-10: ON) on the main board on the heat source unit (OC only) is turned to ON, the unit goes into the refrigerant amount adjust mode, and the following sequence is followed.

Note

- (1) SW4-3 on the OS is invalid, and the unit will not go into the refrigerant amount adjust mode.
- (2) Refer to the relevant sections of the manual for how to set SW4 on the control board.(page 160)

Operation

When the unit is in the refrigerant amount adjust mode, the LEV on the indoor unit does not open as fully as it normally does during cooling operation to secure subcooling.

Note

- 1) Adjust the refrigerant amount based on the TH4 value, following the flowchart below. Check the TH4, SC11, SC16, and Tc values on the OC, OS by following the flowchart. The TH4, SC11, and SC16 values can be displayed by setting the self-diagnosis switch SW4 (SW6-10: OFF) on the main board on the OC, OS.
- 2) There may be cases when the refrigerant amount may seem adequate for a short while after starting the unit in the refrigerant amount adjust mode but turn out to be inadequate later on (when the refrigerant system stabilizes).

When the amount of refrigerant is truly adequate.

Subcool (SC11 and SC16) of the BC controller is 5°C [9°F] or above and SH on the indoor unit is between 5 and 15°C [9 and 27°F].

The refrigerant amount may seem adequate at the moment, but may turn out to be inadequate later on.

Subcool (SC11 and SC16) of the BC controller is 5°C [9°F] or less and SH on the indoor unit is 5°C [9°F] or less.

Wait until the Subcool (SC11 and SC16) of the BC controller reaches 5°C [9°F] or above and the SH of the indoor unit is between 5 and 15°C [9 and 27°F] to determine that the refrigerant amount is adequate.

- ♦SC11: Subcool of liquid refrigerant at BC controller inlet; SC16: Subcool of liquid refrigerant at BC controller outlet
- 3) High pressure must be at least 2.0MPa [290psi] to enable a proper adjustment of refrigerant amount to be made.
 - 4) Refrigerant amount adjust mode automatically ends 90 minutes after beginning. When this happens, by turning off the SW4 No.922 (SW6-10: ON) and turning them back on, the unit will go back into the refrigerant amount adjust mode.

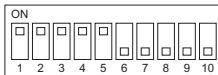
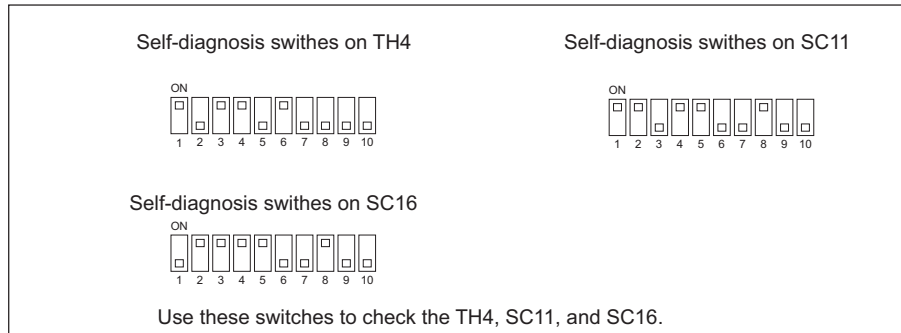

The figure at left shows that the switches 1 through 5 are set to ON and 6 through 10 are set to OFF.

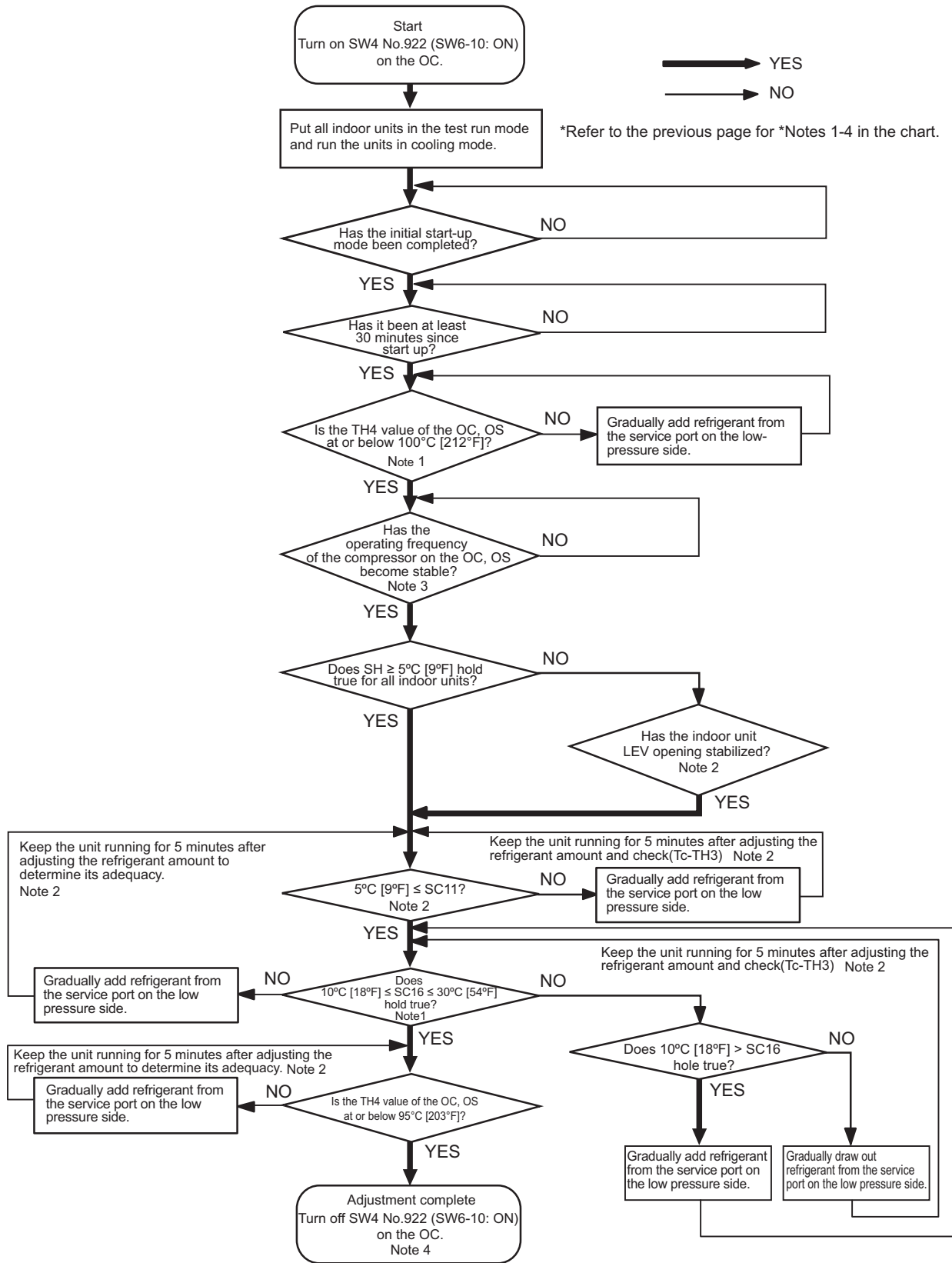

CAUTION
Do not release the extracted refrigerant into the air.

CAUTION
Charge liquid refrigerant (as opposed to gaseous refrigerant) into the system.
• If gaseous refrigerant is charged into the system, the composition of the refrigerant in the cylinder will change and may result in performance loss.

[6] The following symptoms are normal.

Symptoms	Remote controller display	Cause
The indoor unit does not start after starting cooling (heating) operation.	"Cooling (heating)" icon blinks on the display.	The unit cannot perform a heating (cooling) operation when other indoor units are performing a cooling (heating) operation.
The auto vane adjusts its position by itself.	Normal display	After an hour of cooling operation with the auto vane in the vertical position, the vane may automatically move into the horizontal position. Louver blades will automatically move into the horizontal position while the unit is in the defrost mode, pre-heating stand-by mode, or when the thermostat triggers unit off.
The fan keeps running after the unit has stopped.	Unlit	When the auxiliary heater is turned on, the fan operates for one minute after stopping to dissipate heat.
The fan speed does not reach the set speed when operation switch is turned on.	STAND BY	The fan operates at extra low speed for 5 minutes after it is turned on or until the pipe temperature reaches 35°C[95°F], then it operates at low speed for 2 minutes, and finally it operates at the set speed. (Pre-heating stand-by)
When the main power is turned on, the display shown on the right appears on the indoor unit remote controller for 5 minutes.	"HO" or "PLEASE WAIT" icons blink on the display.	The system is starting up. Wait until the blinking display of "HO" or "PLEASE WAIT" go off.
The drain pump keeps running after the unit has stopped.	Unlit	The drain pump stays in operation for three minutes after the unit in the cooling mode is stopped.
The drain pump is running while the unit is stopped.	Unlit	When drain water is detected, the drain pump goes into operation even while the unit is stopped.
Indoor unit and BC controller make noise during cooling/heating changeover.	Normal display	This noise is made when the refrigerant circuit is reversed and is normal.
Sound of the refrigerant flow is heard from the indoor unit immediately after starting operation.	Normal display	This is caused by the transient instability of the refrigerant flow and is normal.
Warm air sometimes comes out of the indoor units that are not in the heating mode.	Normal display	This is due to the fact that the LEVs on some of the indoor units are kept slightly open to prevent the refrigerant in the indoor units that are not operating in the heating mode from liquefying and accumulating in the compressor. It is part of a normal operation.

[7] Standard Operation Data (Reference Data)

1. Single unit <PQHY>

(1) Cooling operation

Item			Heat source unit model		
			PQHY-P72TLMU-A1	PQHY-P96TLMU-A1	
Operating conditions	Indoor temperature	DB/WB	26.7°C/19.4°C [80°F/67°F]	26.7°C/19.4°C [80°F/67°F]	
	Heat source water temperature	°C [°F]	29.4[85]	29.4[85]	
	Heat source water flow rate	m ³ /h [G/h] [gpm]	5.76 [1522] [25.4]	5.76 [1522] [25.4]	
	Indoor unit	No. of connected units	Unit	2	2
		No. of units in operation		2	2
		Model		36/36	48/48
	Pipe length	Main pipe	m [ft]	5 [16-3/8]	5 [16-3/8]
		Branch pipe		10 [32-3/4]	10 [32-3/4]
		Total pipe length		25 [82]	25 [82]
	Fan speed	-	Hi	Hi	
Refrigerant charge	kg [lbs-oz]	11.8 [27]	13.0 [29]		
Heat source unit	Current	A	17.7	23.3	
	Voltage	V	230	230	
	Compressor frequency	Hz	66	90	
LEV opening	Indoor unit	Pulse	325/325	387/387	
	SC (LEV1)		80	100	
	LEV6		41	41	
	LEV7		3000	3000	
Pressure switch	High pressure (after O/S)/ Low pressure (before accumulator)	MPa [psi]	2.20/0.81 [319/117]	2.27/0.81 [329/117]	
Sectional temperatures	Heat source unit	Discharge (TH4)	°C [°F]	65 [149]	65 [149]
		Heat exchanger outlet		33 [91]	34 [93]
		Accumulator inlet		8 [46]	8 [46]
		Accumulator outlet		8 [46]	8 [46]
		Compressor inlet		19 [66]	19 [66]
		Compressor shell bottom		47 [117]	40 [104]
	Indoor unit	LEV inlet		19 [66]	19 [66]
		Heat exchanger outlet		6 [43]	6 [43]

Item			Heat source unit model			
			PQHY-P120TLMU-A1	PQHY-P144TLMU-A1		
Operating conditions	Indoor temperature		DB/WB	26.7°C/19.4°C [80°F/67°F]	26.7°C/19.4°C [80°F/67°F]	
	Heat source water temperature		°C [°F]	29.4[85]	29.4[85]	
	Heat source water flow rate		m ³ /h [G/h] [gpm]	5.76 [1522] [25.4]	7.20 [1902] [31.7]	
	Indoor unit	No. of connected units		Unit	3	4
		No. of units in operation			3	4
		Model			-	36/36/48
	Pipe length	Main pipe		m [ft]	5 [16-3/8]	5 [16-3/8]
		Branch pipe			10 [32-3/4]	10 [32-3/4]
		Total pipe length			35 [115]	45 [148]
	Fan speed		-	Hi	Hi	
Refrigerant charge		kg [lbs-oz]	13.6 [30]	16.3 [36]		
Heat source unit	Current		A	23.8	24.4	
	Voltage		V	230	230	
	Compressor frequency		Hz	114	82	
LEV opening	Indoor unit		Pulse	325/325/387	325/325/325/325	
	SC (LEV1)			100	160	
	LEV6			41	41	
	LEV7			3000	3000	
Pressure switch	High pressure (after O/S)/ Low pressure (before accumulator)		MPa [psi]	2.30/0.81 [334/117]	2.36/0.81 [342/117]	
Sectional temperatures	Heat source unit	Discharge (TH4)		65 [149]	65 [149]	
		Heat exchanger outlet		35 [95]	36 [97]	
		Accumulator inlet		8 [46]	8 [46]	
		Accumulator outlet		8 [46]	8 [46]	
		Compressor inlet		19 [66]	19 [66]	
		Compressor shell bottom		42 [108]	42 [108]	
	Indoor unit	LEV inlet		19 [66]	19 [66]	
		Heat exchanger outlet		6 [43]	6 [43]	

Item			Heat source unit model			
			PQHY-P168TLMU-A1	PQHY-P192TLMU-A1		
Operating conditions	Indoor temperature		DB/WB	26.7°C/19.4°C [80°F/67°F]	26.7°C/19.4°C [80°F/67°F]	
	Heat source water temperature		°C [°F]	29.4[85]	29.4[85]	
	Heat source water flow rate		m ³ /h [G/h] [gpm]	7.20 [1902] [31.7]	7.20 [1902] [31.7]	
	Indoor unit	No. of connected units		Unit	4	4
		No. of units in operation			4	4
		Model			-	36/36/48/48
	Pipe length	Main pipe		m [ft]	5 [16-3/8]	5 [16-3/8]
		Branch pipe			10 [32-3/4]	10 [32-3/4]
		Total pipe length			45 [148]	45 [148]
	Fan speed		-	Hi	Hi	
Refrigerant charge		kg [lbs-oz]	19.1 [43]	20.6 [46]		
Heat source unit	Current		A	33.6	41.9	
	Voltage		V	230	230	
	Compressor frequency		Hz	97	112	
LEV opening	Indoor unit		Pulse	325/325/387/387		
	SC (LEV1)			180	200	
	LEV6			41	41	
	LEV7			3000	3000	
Pressure switch	High pressure (after O/S)/ Low pressure (before accumulator)		MPa [psi]	2.48/0.81 [360/117]	2.56/0.81 [371/117]	
Sectional temperatures	Heat source unit	Discharge (TH4)		65 [149]	65 [149]	
		Heat exchanger outlet		38 [100]	39 [102]	
		Accumulator inlet		8 [46]	8 [46]	
		Accumulator outlet		8 [46]	8 [46]	
		Compressor inlet		19 [66]	19 [66]	
		Compressor shell bottom		42 [108]	42 [108]	
	Indoor unit	LEV inlet		19 [66]	19 [66]	
		Heat exchanger outlet		6 [43]	6 [43]	

Item			Heat source unit model			
			PQHY-P216TLMU-A1	PQHY-P240TLMU-A1		
Operating conditions	Indoor temperature		DB/WB	26.7°C/19.4°C [80°F/67°F]	26.7°C/19.4°C [80°F/67°F]	
	Heat source water temperature		°C [°F]	29.4[85]	29.4[85]	
	Heat source water flow rate		m ³ /h [G/h] [gpm]	11.52 [3044] [50.7]	11.52 [3044] [50.7]	
	Indoor unit	No. of connected units		Unit	5	6
		No. of units in operation			5	6
		Model			-	36/36/48/48/48
	Pipe length	Main pipe		m [ft]	5 [16-3/8]	5 [16-3/8]
		Branch pipe			10 [32-3/4]	10 [32-3/4]
		Total pipe length			65 [213-1/4]	65 [213-1/4]
	Fan speed		-	Hi	Hi	
Refrigerant charge		kg [lbs-oz]	28.9 [64]	28.9 [64]		
Heat source unit	Current		A	53.6	58.9	
	Voltage		V	230	230	
	Compressor frequency		Hz	112	120	
LEV opening	Indoor unit		Pulse	325/325/387/387/387	325/325/325/325/387/387	
	SC (LEV1)			318	318	
	LEV6			41	41	
	LEV7			3000	3000	
Pressure switch	High pressure (after O/S)/ Low pressure (before accumulator)		MPa [psi]	2.51/0.81 [364/117]	2.62/0.81 [380/117]	
Sectional temperatures	Heat source unit	Discharge (TH4)		65 [149]	65 [149]	
		Heat exchanger outlet		39 [102]	40 [104]	
		Accumulator inlet		8 [46]	8 [46]	
		Accumulator outlet		8 [46]	8 [46]	
		Compressor inlet		19 [66]	19 [66]	
		Compressor shell bottom		42 [108]	42 [108]	
	Indoor unit	LEV inlet		19 [66]	19 [66]	
		Heat exchanger outlet		6 [43]	6 [43]	

(2) Heating operation

Item			Heat source unit model			
			PQHY-P72TLMU-A1	PQHY-P96TLMU-A1		
Operating conditions	Indoor temperature		DB/WB	21.1°C/- [70°F/-]	21.1°C/- [70°F/-]	
	Heat source water temperature		°C [°F]	21.1[70]	21.1[70]	
	Heat source water flow rate		m ³ /h [G/h] [gpm]	5.76 [1522] [25.4]	5.76 [1522] [25.4]	
	Indoor unit	No. of connected units		Unit	2	2
		No. of units in operation			2	2
		Model			-	36/36
	Pipe length	Main pipe		m [ft]	5 [16-3/8]	5 [16-3/8]
		Branch pipe			10 [32-3/4]	10 [32-3/4]
		Total pipe length			25 [82]	25 [82]
	Fan speed		-	Hi	Hi	
Refrigerant charge		kg [lbs-oz]	11.8 [27]	13.0 [29]		
Heat source unit	Current		A	18.6	25.2	
	Voltage		V	230	230	
	Compressor frequency		Hz	60	72	
LEV opening	Indoor unit		Pulse	332/332	406/406	
	SC (LEV1)			0	0	
	LEV6			68	84	
	LEV7			3000	3000	
Pressure switch	High pressure (after O/S)/ Low pressure (before accumulator)		MPa [psi]	2.64/0.80 [383/116]	2.90/0.80 [421/116]	
Sectional temperatures	Heat source unit	Discharge (TH4)		73 [163]	80 [176]	
		Heat exchanger outlet		5 [41]	5 [41]	
		Accumulator inlet		4 [39]	4 [39]	
		Accumulator outlet		4 [39]	4 [39]	
		Compressor inlet		4 [39]	4 [39]	
		Compressor shell bottom		40 [104]	40 [104]	
	Indoor unit	LEV inlet		37 [99]	38 [100]	
		Heat exchanger inlet		70 [158]	70 [158]	

Item			Heat source unit model			
			PQHY-P120TLMU-A1	PQHY-P144TLMU-A1		
Operating conditions	Indoor temperature		DB/WB	21.1°C/- [70°F/-]	21.1°C/- [70°F/-]	
	Heat source water temperature		°C [°F]	21.1[70]	21.1[70]	
	Heat source water flow rate		m ³ /h [G/h] [gpm]	5.76 [1522] [25.4]	7.20 [1902] [31.7]	
	Indoor unit	No. of connected units		Unit	3	4
		No. of units in operation			3	4
		Model			36/36/48	36/36/36/36
	Pipe length	Main pipe		m [ft]	5 [16-3/8]	5 [16-3/8]
		Branch pipe			10 [32-3/4]	10 [32-3/4]
		Total pipe length			35 [115]	45 [148]
	Fan speed		-	Hi	Hi	
Refrigerant charge		kg [lbs-oz]	13.6 [30]	16.3 [36]		
Heat source unit	Current		A	28.3	29.1	
	Voltage		V	230	230	
	Compressor frequency		Hz	90	75	
LEV opening	Indoor unit		Pulse	332/332/406	332/332/332/332	
	SC (LEV1)			0	0	
	LEV6			122	136	
	LEV7			3000	3000	
Pressure switch	High pressure (after O/S)/ Low pressure (before accumulator)		MPa [psi]	2.68/0.80 [389/116]	2.54/0.80 [368/116]	
Sectional temperatures	Heat source unit	Discharge (TH4)		81 [178]	77 [171]	
		Heat exchanger outlet		5 [41]	5 [41]	
		Accumulator inlet		4 [39]	4 [39]	
		Accumulator outlet		4 [39]	4 [39]	
		Compressor inlet		4 [39]	4 [39]	
		Compressor shell bottom		40 [104]	40 [104]	
	Indoor unit	LEV inlet		39 [102]	36 [97]	
		Heat exchanger inlet		70 [158]	70 [158]	

Item			Heat source unit model			
			PQHY-P168TLMU-A1	PQHY-P192TLMU-A1		
Operating conditions	Indoor temperature		DB/WB	21.1°C/- [70°F/-]	21.1°C/- [70°F/-]	
	Heat source water temperature		°C [°F]	21.1[70]	21.1[70]	
	Heat source water flow rate		m ³ /h [G/h] [gpm]	7.20 [1902] [31.7]	7.20 [1902] [31.7]	
	Indoor unit	No. of connected units		Unit	4	4
		No. of units in operation			4	4
		Model			36/36/48/48	48/48/48/48
	Pipe length	Main pipe		m [ft]	5 [16-3/8]	5 [16-3/8]
		Branch pipe			10 [32-3/4]	10 [32-3/4]
		Total pipe length			45 [148]	45 [148]
	Fan speed		-	Hi	Hi	
Refrigerant charge		kg [lbs-oz]	19.1 [43]	20.6 [46]		
Heat source unit	Current		A	40.0	49.9	
	Voltage		V	230	230	
	Compressor frequency		Hz	82	90	
LEV opening	Indoor unit		Pulse	332/332/406/406	406/406/406/406	
	SC (LEV1)			0	0	
	LEV6			152	168	
	LEV7			3000	3000	
Pressure switch	High pressure (after O/S)/ Low pressure (before accumulator)		MPa [psi]	2.62/0.80 [380/116]	2.64/0.80 [383/116]	
Sectional temperatures	Heat source unit	Discharge (TH4)		77 [171]	80 176	
		Heat exchanger outlet		5 [41]	5 [41]	
		Accumulator inlet		4 [39]	4 [39]	
		Accumulator outlet		4 [39]	4 [39]	
		Compressor inlet		4 [39]	4 [39]	
		Compressor shell bottom		40 [104]	40 [104]	
	Indoor unit	LEV inlet		37 [99]	37 [99]	
		Heat exchanger inlet		70 [158]	70 [158]	

Item			Heat source unit model			
			PQHY-P216TLMU-A1	PQHY-P240TLMU-A1		
Operating conditions	Indoor temperature		DB/WB	21.1°C/- [70°F/-]	21.1°C/- [70°F/-]	
	Heat source water temperature		°C [°F]	21.1[70]	21.1[70]	
	Heat source water flow rate		m ³ /h [G/h] [gpm]	11.52 [3044] [50.7]	11.52 [3044] [50.7]	
	Indoor unit	No. of connected units		Unit	5	6
		No. of units in operation			5	6
		Model			36/36/48/48/48	36/36/36/36/48/48
	Pipe length	Main pipe		m [ft]	5 [16-3/8]	5 [16-3/8]
		Branch pipe			10 [32-3/4]	10 [32-3/4]
		Total pipe length			65 [213-1/4]	65 [213-1/4]
	Fan speed		-	Hi	Hi	
Refrigerant charge		kg [lbs-oz]	28.9 [64]	28.9 [64]		
Heat source unit	Current		A	63.8	70.1	
	Voltage		V	230	230	
	Compressor frequency		Hz	93	103	
LEV opening	Indoor unit		Pulse	332/332/406/406/406	332/332/332/332/406/406	
	SC (LEV1)			0	0	
	LEV6			206	244	
	LEV7			3000	3000	
Pressure switch	High pressure (after O/S)/ Low pressure (before accumulator)		MPa [psi]	2.64/0.80 [383/116]	2.69/0.80 [390/116]	
Sectional temperatures	Heat source unit	Discharge (TH4)		81 [178]	81 [178]	
		Heat exchanger outlet		5 [41]	5 [41]	
		Accumulator inlet		4 [39]	4 [39]	
		Accumulator outlet		4 [39]	4 [39]	
		Compressor inlet		4 [39]	4 [39]	
		Compressor shell bottom		40 [104]	40 [104]	
	Indoor unit	LEV inlet		37 [99]	38 [100]	
		Heat exchanger inlet		70 [158]	70 [158]	

2. 2-unit combination <PQHY>

(1) Cooling operation

Item			2-unit combination			
			PQHY-P144TSLMU-A1			
			PQHY-P72TLMU-A1	PQHY-P72TLMU-A1		
Operating conditions	Indoor temperature		DB/WB	26.7°C/19.4°C[80°F/67°F]		
	Heat source water temperature		°C [°F]	29.4[85]		
	Heat source water flow rate		m ³ /h G/h gpm	5.76 [1522] [25.4]	5.76 [1522] [25.4]	
	Indoor unit	No. of connected units		Unit	4	
		No. of units in operation			4	
		Model		-	36/36/36/36	
	Pipe length	Main pipe		m [ft]	5 [16-3/8]	
		Branch pipe			10 [32-3/4]	
		Total pipe length			45 [148]	
	Fan speed		-	Hi		
Refrigerant charge		kg [lbs-oz]	20.3 [45]			
Heat source unit	Current		A	42.3		
	Voltage		V	230		
	Compressor frequency		Hz	66	66	
LEV opening	Indoor unit		Pulse	325/325/325/325		
	SC (LEV1)			80	80	
	LEV6			41	41	
	LEV7			3000	3000	
Pressure switch	High pressure (after O/S)/ Low pressure (before accumulator)		MPa [psi]	2.20/0.81 [319/117]	2.20/0.81 [319/117]	
Sectional temperatures	Heat source unit	Discharge (TH4)		65 [149]	65 [149]	
		Heat exchanger outlet		33 [91]	33 [91]	
		Accumulator inlet		8 [46]	8 [46]	
		Accumulator outlet		8 [46]	8 [46]	
		Compressor inlet		19 [66]	19 [66]	
		Compressor shell bottom		47 [117]	47 [117]	
	Indoor unit	LEV inlet		19 [66]		
		Heat exchanger outlet		6 [43]		

Item			2-unit combination			
			PQHY-P168TSLMU-A1			
			PQHY-P96TLMU-A1	PQHY-P72TLMU-A1		
Operating conditions	Indoor temperature		DB/WB	26.7°C/19.4°C[80°F/67°F]		
	Heat source water temperature		°C [°F]	29.4[85]		
	Heat source water flow rate		m ³ /h G/h gpm	5.76 [1522] [25.4]	5.76 [1522] [25.4]	
	Indoor unit	No. of connected units		Unit	4	
		No. of units in operation			4	
		Model			36/36/48/48	
	Pipe length	Main pipe		m [ft]	5 [16-3/8]	
		Branch pipe			10 [32-3/4]	
		Total pipe length			45 [148]	
	Fan speed		-	Hi		
Refrigerant charge		kg [lbs-oz]	23.1 [51]			
Heat source unit	Current		A	42.3		
	Voltage		V	230		
	Compressor frequency		Hz	78	78	
LEV opening	Indoor unit		Pulse	325/325/387/387		
	SC (LEV1)			90	90	
	LEV6			41	41	
	LEV7			3000	3000	
Pressure switch	High pressure (after O/S)/ Low pressure (before accumulator)		MPa [psi]	2.23/0.81 [323/117]	2.23/0.81 [323/117]	
Sectional temperatures	Heat source unit	Discharge (TH4)		°C [°F]	65 [149]	65 [149]
		Heat exchanger outlet			33 [91]	33 [91]
		Accumulator inlet			8 [46]	8 [46]
		Accumulator outlet			8 [46]	8 [46]
		Compressor inlet			19 [66]	19 [66]
		Compressor shell bottom			40 [104]	47 [117]
	Indoor unit	LEV inlet		19 [66]		
		Heat exchanger outlet		6 [43]		

Item			2-unit combination			
			PQHY-P192TSLMU-A1			
			PQHY-P96TLMU-A1	PQHY-P96TLMU-A1		
Operating conditions	Indoor temperature		DB/WB	26.7°C/19.4°C[80°F/67°F]		
	Heat source water temperature		°C [°F]	29.4[85]		
	Heat source water flow rate		m ³ /h G/h gpm	5.76 [1522] [25.4]	5.76 [1522] [25.4]	
	Indoor unit	No. of connected units		Unit	4	
		No. of units in operation			4	
		Model			48/48/48/48	
	Pipe length	Main pipe		m [ft]	5 [16-3/8]	
		Branch pipe			10 [32-3/4]	
		Total pipe length			45 [148]	
	Fan speed		-	Hi		
Refrigerant charge		kg [lbs-oz]	24.6 [54]			
Heat source unit	Current		A	51.8		
	Voltage		V	230		
	Compressor frequency		Hz	90	90	
LEV opening	Indoor unit		Pulse	387/387/387/387		
	SC (LEV1)			100	100	
	LEV6			41	41	
	LEV7			3000	3000	
Pressure switch	High pressure (after O/S)/ Low pressure (before accumulator)		MPa [psi]	2.27/0.81 [329/117]	2.27/0.81 [329/117]	
Sectional temperatures	Heat source unit	Discharge (TH4)		°C [°F]	65 [149]	65 [149]
		Heat exchanger outlet			34 [93]	34 [93]
		Accumulator inlet			8 [46]	8 [46]
		Accumulator outlet			8 [46]	8 [46]
		Compressor inlet			19 [66]	19 [66]
		Compressor shell bottom			40 [104]	40 [104]
	Indoor unit	LEV inlet		19 [66]		
		Heat exchanger outlet		6 [43]		

Item			2-unit combination			
			PQHY-P216TSLMU-A1			
			PQHY-P120TLMU-A1	PQHY-P96TLMU-A1		
Operating conditions	Indoor temperature		DB/WB	26.7°C/19.4°C[80°F/67°F]		
	Heat source water temperature		°C [°F]	29.4[85]		
	Heat source water flow rate		m ³ /h G/h gpm	5.76 [1522] [25.4]	5.76 [1522] [25.4]	
	Indoor unit	No. of connected units		Unit	5	
		No. of units in operation			5	
		Model			36/36/48/48/48	
	Pipe length	Main pipe		m [ft]	5 [16-3/8]	
		Branch pipe			10 [32-3/4]	
		Total pipe length			65 [213-1/4]	
	Fan speed		-	Hi		
Refrigerant charge		kg [lbs-oz]	26.2 [58]			
Heat source unit	Current		A	52.2		
	Voltage		V	230		
	Compressor frequency		Hz	98	98	
LEV opening	Indoor unit		Pulse	325/325/387/387/387		
	SC (LEV1)			159	159	
	LEV6			41	41	
	LEV7			3000	3000	
Pressure switch	High pressure (after O/S)/ Low pressure (before accumulator)		MPa [psi]	2.28/0.81 [331/117]	2.28/0.81 [331/117]	
Sectional temperatures	Heat source unit	Discharge (TH4)		°C [°F]	65 [149]	65 [149]
		Heat exchanger outlet			35 [95]	35 [95]
		Accumulator inlet			8 [46]	8 [46]
		Accumulator outlet			8 [46]	8 [46]
		Compressor inlet			19 [66]	19 [66]
		Compressor shell bottom			42 [108]	40 [104]
	Indoor unit	LEV inlet		19 [66]		
		Heat exchanger outlet		6 [43]		

Item			2-unit combination			
			PQHY-P240TSLMU-A1			
			PQHY-P120TLMU-A1	PQHY-P120TLMU-A1		
Operating conditions	Indoor temperature		DB/WB	26.7°C/19.4°C[80°F/67°F]		
	Heat source water temperature		°C [°F]	29.4[85]		
	Heat source water flow rate		m ³ /h G/h gpm	5.76 [1522] [25.4]	5.76 [1522] [25.4]	
	Indoor unit	No. of connected units		Unit	6	
		No. of units in operation			6	
		Model			36/36/36/36/48/48	
	Pipe length	Main pipe		m [ft]	5 [16-3/8]	
		Branch pipe			10 [32-3/4]	
		Total pipe length			65 [213-1/4]	
	Fan speed		-	Hi		
Refrigerant charge		kg [lbs-oz]	26.2 [58]			
Heat source unit	Current		A	56.9		
	Voltage		V	230		
	Compressor frequency		Hz	105	105	
LEV opening	Indoor unit		Pulse	325/325/325/325/387/387		
	SC (LEV1)			159	159	
	LEV6			41	41	
	LEV7			3000	3000	
Pressure switch	High pressure (after O/S)/ Low pressure (before accumulator)		MPa [psi]	2.30/0.81 [334/117]	2.30/0.81 [334/117]	
Sectional temperatures	Heat source unit	Discharge (TH4)		65 [149]	65 [149]	
		Heat exchanger outlet		35 [95]	35 [95]	
		Accumulator inlet		8 [46]	8 [46]	
		Accumulator outlet		8 [46]	8 [46]	
		Compressor inlet		19 [66]	19 [66]	
		Compressor shell bottom		42 [108]	42 [108]	
	Indoor unit	LEV inlet		19 [66]		
		Heat exchanger outlet		6 [43]		

Item			2-unit combination			
			PQHY-P288TSLMU-A1			
			PQHY-P144TLMU-A1	PQHY-P144TLMU-A1		
Operating conditions	Indoor temperature		DB/WB	26.7°C/19.4°C[80°F/67°F]		
	Heat source water temperature		°C [°F]	29.4[85]		
	Heat source water flow rate		m ³ /h G/h gpm	7.20 [1902] [31.7]	7.20 [1902] [31.7]	
	Indoor unit	No. of connected units		Unit	6	
		No. of units in operation			6	
		Model			48/48/48/48/48/48	
	Pipe length	Main pipe		m [ft]	5 [16-3/8]	
		Branch pipe			10 [32-3/4]	
		Total pipe length			65 [213-1/4]	
	Fan speed		-	Hi		
Refrigerant charge		kg [lbs-oz]	22.5 [50]			
Heat source unit	Current		A	56.9		
	Voltage		V	230		
	Compressor frequency		Hz	84	84	
LEV opening	Indoor unit		Pulse	387/387/387/387/387/387		
	SC (LEV1)			234	234	
	LEV6			41	41	
	LEV7			3000	3000	
Pressure switch	High pressure (after O/S)/ Low pressure (before accumulator)		MPa [psi]	2.36/0.81 [342/117]	2.36/0.81 [342/117]	
Sectional temperatures	Heat source unit	Discharge (TH4)		°C [°F]	65 [149]	65 [149]
		Heat exchanger outlet			36 [93]	36 [93]
		Accumulator inlet			8 [46]	8 [46]
		Accumulator outlet			8 [46]	8 [46]
		Compressor inlet			19 [66]	19 [66]
		Compressor shell bottom			40 [104]	40 [104]
	Indoor unit	LEV inlet		19 [66]		
		Heat exchanger outlet		6 [43]		

Item			2-unit combination			
			PQHY-P312TSLMU-A1			
			PQHY-P168TLMU-A1	PQHY-P144TLMU-A1		
Operating conditions	Indoor temperature		DB/WB	26.7°C/19.4°C[80°F/67°F]		
	Heat source water temperature		°C [°F]	29.4[85]		
	Heat source water flow rate		m ³ /h G/h gpm	7.20 [1902] [31.7]	7.20 [1902] [31.7]	
	Indoor unit	No. of connected units		Unit	6	
		No. of units in operation			6	
		Model		-	54/54/54/54/48/48	
	Pipe length	Main pipe		m [ft]	5 [16-3/8]	
		Branch pipe			10 [32-3/4]	
		Total pipe length			65 [213-1/4]	
	Fan speed		-	Hi		
Refrigerant charge		kg [lbs-oz]	22.5 [50]			
Heat source unit	Current		A	65.2		
	Voltage		V	230		
	Compressor frequency		Hz	89	89	
LEV opening	Indoor unit		Pulse	395/395/395/387/387/387		
	SC (LEV1)			234	234	
	LEV6			41	41	
	LEV7			3000	3000	
Pressure switch	High pressure (after O/S)/ Low pressure (before accumulator)		MPa [psi]	2.42/0.81 [351/117]	2.42/0.81 [351/117]	
Sectional temperatures	Heat source unit	Discharge (TH4)		65 [149]	65 [149]	
		Heat exchanger outlet		37 [93]	37 [93]	
		Accumulator inlet		8 [46]	8 [46]	
		Accumulator outlet		8 [46]	8 [46]	
		Compressor inlet		19 [66]	19 [66]	
		Compressor shell bottom		40 [104]	40 [104]	
	Indoor unit	LEV inlet		19 [66]		
		Heat exchanger outlet		6 [43]		

Item			2-unit combination			
			PQHY-P336TSLMU-A1			
			PQHY-P168TLMU-A1	PQHY-P168TLMU-A1		
Operating conditions	Indoor temperature		DB/WB	26.7°C/19.4°C[80°F/67°F]		
	Heat source water temperature		°C [°F]	29.4[85]		
	Heat source water flow rate		m ³ /h G/h gpm	7.20 [1902] [31.7]	7.20 [1902] [31.7]	
	Indoor unit	No. of connected units		Unit	7	
		No. of units in operation			7	
		Model			48/48/48/48/48/48/48	
	Pipe length	Main pipe		m [ft]	5 [16-3/8]	
		Branch pipe			10 [32-3/4]	
		Total pipe length			65 [213-1/4]	
	Fan speed		-	Hi		
Refrigerant charge		kg [lbs-oz]	23.5 [52]			
Heat source unit	Current		A	74.8		
	Voltage		V	230		
	Compressor frequency		Hz	93	93	
LEV opening	Indoor unit		Pulse	387/387/387/387/387/387/387		
	SC (LEV1)			234	234	
	LEV6			41	41	
	LEV7			3000	3000	
Pressure switch	High pressure (after O/S)/ Low pressure (before accumulator)		MPa [psi]	2.48/0.81 [360/117]	2.48/0.81 [360/117]	
Sectional temperatures	Heat source unit	Discharge (TH4)		65 [149]	65 [149]	
		Heat exchanger outlet		38 [95]	38 [95]	
		Accumulator inlet		8 [46]	8 [46]	
		Accumulator outlet		8 [46]	8 [46]	
		Compressor inlet		19 [66]	19 [66]	
		Compressor shell bottom		40 [104]	40 [104]	
	Indoor unit	LEV inlet		19 [66]		
		Heat exchanger outlet		6 [43]		

Item			2-unit combination			
			PQHY-P360TSLMU-A1			
			PQHY-P192TLMU-A1	PQHY-P168TLMU-A1		
Operating conditions	Indoor temperature		DB/WB	26.7°C/19.4°C[80°F/67°F]		
	Heat source water temperature		°C [°F]	29.4[85]		
	Heat source water flow rate		m ³ /h G/h gpm	7.20 [1902] [31.7]	7.20 [1902] [31.7]	
	Indoor unit	No. of connected units		Unit	7	
		No. of units in operation			7	
		Model			54/54/54/54/48/48/48	
	Pipe length	Main pipe		m [ft]	5 [16-3/8]	
		Branch pipe			10 [32-3/4]	
		Total pipe length			75 [246-1/16]	
	Fan speed		-	Hi		
Refrigerant charge		kg [lbs-oz]	23.8 [53]			
Heat source unit	Current		A	82.0		
	Voltage		V	230		
	Compressor frequency		Hz	98	98	
LEV opening	Indoor unit		Pulse	395/395/395/395/387/387/387		
	SC (LEV1)			150	150	
	LEV6			41	41	
	LEV7			3000	3000	
Pressure switch	High pressure (after O/S)/ Low pressure (before accumulator)		MPa [psi]	2.52/0.81 [365/117]	2.52/0.81 [365/117]	
	Sectional temperatures	Heat source unit	Discharge (TH4)		65 [149]	65 [149]
Heat exchanger outlet			39 [95]	39 [95]		
Accumulator inlet			8 [46]	8 [46]		
Accumulator outlet			8 [46]	8 [46]		
Compressor inlet			19 [66]	19 [66]		
Compressor shell bottom			42 [108]	42 [108]		
Indoor unit	LEV inlet		19 [66]			
	Heat exchanger outlet		6 [43]			

(2) Heating operation

Item			2-unit combination			
			PQHY-P144TSLMU-A1			
			PQHY-P72TLMU-A1	PQHY-P72TLMU-A1		
Operating conditions	Indoor temperature		DB/WB	21.1°C/[70°F/-]		
	Heat source water temperature		°C [°F]	21.1[70]		
	Heat source water flow rate		m ³ /h G/h gpm	5.76 [1522] [25.4]	5.76 [1522] [25.4]	
	Indoor unit	No. of connected units		Unit	4	
		No. of units in operation			4	
		Model			36/36/36/36	
	Pipe length	Main pipe		m [ft]	5 [16-3/8]	
		Branch pipe			10 [32-3/4]	
		Total pipe length			45 [148]	
	Fan speed		-	Hi		
Refrigerant charge		kg [lbs-oz]	20.3 [45]			
Heat source unit	Current		A	44.3		
	Voltage		V	230		
	Compressor frequency		Hz	60	60	
LEV opening	Indoor unit		Pulse	332/332/332/332		
	SC (LEV1)			0	0	
	LEV6			68	68	
	LEV7			3000	3000	
Pressure switch	High pressure (after O/S)/ Low pressure (before accumulator)		MPa [psi]	2.64/0.80 [383/116]	2.64/0.80 [383/116]	
Sectional temperatures	Heat source unit	Discharge (TH4)		77 [171]	77 [171]	
		Heat exchanger outlet		5 [41]	5 [41]	
		Accumulator inlet		4 [39]	4 [39]	
		Accumulator outlet		4 [39]	4 [39]	
		Compressor inlet		4 [39]	4 [39]	
		Compressor shell bottom		40 [104]	40 [104]	
	Indoor unit	LEV inlet		37 [99]		
		Heat exchanger inlet		70 [158]		

Item			2-unit combination			
			PQHY-P168TSLMU-A1			
			PQHY-P96TLMU-A1	PQHY-P72TLMU-A1		
Operating conditions	Indoor temperature		DB/WB	21.1°C/[70°F/-]		
	Heat source water temperature		°C [°F]	21.1[70]		
	Heat source water flow rate		m ³ /h G/h gpm	5.76 [1522] [25.4]	5.76 [1522] [25.4]	
	Indoor unit	No. of connected units		Unit	4	
		No. of units in operation			4	
		Model			36/36/48/48	
	Pipe length	Main pipe		m [ft]	5 [16-3/8]	
		Branch pipe			10 [32-3/4]	
		Total pipe length			45 [148]	
	Fan speed		-	Hi		
Refrigerant charge		kg [lbs-oz]	23.1 [51]			
Heat source unit	Current		A	44.3		
	Voltage		V	230		
	Compressor frequency		Hz	66	66	
LEV opening	Indoor unit		Pulse	332/332/406/406		
	SC (LEV1)			0	0	
	LEV6			84	68	
	LEV7			3000	3000	
Pressure switch	High pressure (after O/S)/ Low pressure (before accumulator)		MPa [psi]	2.80/0.80 [406/116]	2.80/0.80 [406/116]	
Sectional temperatures	Heat source unit	Discharge (TH4)		77 [171]	77 [171]	
		Heat exchanger outlet		5 [41]	5 [41]	
		Accumulator inlet		4 [39]	4 [39]	
		Accumulator outlet		4 [39]	4 [39]	
		Compressor inlet		4 [39]	4 [39]	
		Compressor shell bottom		40 [104]	40 [104]	
	Indoor unit	LEV inlet		37 [99]		
		Heat exchanger inlet		70 [158]		

Item			2-unit combination			
			PQHY-P192TSLMU-A1			
			PQHY-P96TLMU-A1	PQHY-P96TLMU-A1		
Operating conditions	Indoor temperature		DB/WB	21.1°C/-[70°F/-]		
	Heat source water temperature		°C [°F]	21.1[70]		
	Heat source water flow rate		m ³ /h G/h gpm	5.76 [1522] [25.4]	5.76 [1522] [25.4]	
	Indoor unit	No. of connected units		Unit	4	
		No. of units in operation			4	
		Model			48/48/48/48	
	Pipe length	Main pipe		m [ft]	5 [16-3/8]	
		Branch pipe			10 [32-3/4]	
		Total pipe length			45 [148]	
	Fan speed		-	Hi		
Refrigerant charge		kg [lbs-oz]	24.6 [54]			
Heat source unit	Current		A	51.1		
	Voltage		V	230		
	Compressor frequency		Hz	72	72	
LEV opening	Indoor unit		Pulse	406/406/406/406		
	SC (LEV1)			0	0	
	LEV6			84	84	
	LEV7			3000	3000	
Pressure switch	High pressure (after O/S)/ Low pressure (before accumulator)		MPa [psi]	2.90/0.80 [421/116]	2.90/0.80 [421/116]	
Sectional temperatures	Heat source unit	Discharge (TH4)		80 [176]	80 [176]	
		Heat exchanger outlet		5 [41]	5 [41]	
		Accumulator inlet		4 [39]	4 [39]	
		Accumulator outlet		4 [39]	4 [39]	
		Compressor inlet		4 [39]	4 [39]	
		Compressor shell bottom		40 [104]	40 [104]	
	Indoor unit	LEV inlet		37 [99]		
		Heat exchanger inlet		70 [158]		

Item			2-unit combination			
			PQHY-P216TSLMU-A1			
			PQHY-P120TLMU-A1	PQHY-P96TLMU-A1		
Operating conditions	Indoor temperature		DB/WB	21.1°C/[70°F/-]		
	Heat source water temperature		°C [°F]	21.1[70]		
	Heat source water flow rate		m ³ /h G/h gpm	5.76 [1522] [25.4]	5.76 [1522] [25.4]	
	Indoor unit	No. of connected units		Unit	5	
		No. of units in operation			5	
		Model			36/36/48/48/48	
	Pipe length	Main pipe		m [ft]	5 [16-3/8]	
		Branch pipe			10 [32-3/4]	
		Total pipe length			65 [213-1/4]	
	Fan speed		-	Hi		
Refrigerant charge		kg [lbs-oz]	26.2 [58]			
Heat source unit	Current		A	55.1		
	Voltage		V	230		
	Compressor frequency		Hz	81	81	
LEV opening	Indoor unit		Pulse	332/332/406/406/406		
	SC (LEV1)			0	0	
	LEV6			122	84	
	LEV7			3000	3000	
Pressure switch	High pressure (after O/S)/ Low pressure (before accumulator)		MPa [psi]	2.75/0.80 [399/116]	2.75/0.80 [399/116]	
Sectional temperatures	Heat source unit	Discharge (TH4)		°C [°F]	81 [178]	81 [178]
		Heat exchanger outlet			5 [41]	5 [41]
		Accumulator inlet			4 [39]	4 [39]
		Accumulator outlet			4 [39]	4 [39]
		Compressor inlet			4 [39]	4 [39]
		Compressor shell bottom			40 [104]	40 [104]
	Indoor unit	LEV inlet		35 [95]		
		Heat exchanger inlet		70 [158]		

Item			2-unit combination			
			PQHY-P240TSLMU-A1			
			PQHY-P120TLMU-A1	PQHY-P120TLMU-A1		
Operating conditions	Indoor temperature		DB/WB	21.1°C/[70°F/-]		
	Heat source water temperature		°C [°F]	21.1[70]		
	Heat source water flow rate		m ³ /h G/h gpm	5.76 [1522] [25.4]	5.76 [1522] [25.4]	
	Indoor unit	No. of connected units		Unit	6	
		No. of units in operation			6	
		Model			36/36/36/36/48/48	
	Pipe length	Main pipe		m [ft]	5 [16-3/8]	
		Branch pipe			10 [32-3/4]	
		Total pipe length			65 [213-1/4]	
	Fan speed		-	Hi		
Refrigerant charge		kg [lbs-oz]	26.2 [58]			
Heat source unit	Current		A	58.3		
	Voltage		V	230		
	Compressor frequency		Hz	90	90	
LEV opening	Indoor unit		Pulse	332/332/332/332/406/406		
	SC (LEV1)			0	0	
	LEV6			122	122	
	LEV7			3000	3000	
Pressure switch	High pressure (after O/S)/ Low pressure (before accumulator)		MPa [psi]	2.68/0.80 [389/116]	2.68/0.80 [389/116]	
Sectional temperatures	Heat source unit	Discharge (TH4)		°C [°F]	81 [178]	81 [178]
		Heat exchanger outlet			5 [41]	5 [41]
		Accumulator inlet			4 [39]	4 [39]
		Accumulator outlet			4 [39]	4 [39]
		Compressor inlet			4 [39]	4 [39]
		Compressor shell bottom			40 [104]	40 [104]
	Indoor unit	LEV inlet		35 [95]		
		Heat exchanger inlet		70 [158]		

Item			2-unit combination			
			PQHY-P288TSLMU-A1			
			PQHY-P144TLMU-A1	PQHY-P144TLMU-A1		
Operating conditions	Indoor temperature		DB/WB	21.1°C/[70°F/-]		
	Heat source water temperature		°C [°F]	21.1[70]		
	Heat source water flow rate		m ³ /h G/h gpm	7.20 [1902] [31.7]	7.20 [1902] [31.7]	
	Indoor unit	No. of connected units		Unit	6	
		No. of units in operation			6	
		Model			48/48/48/48/48/48	
	Pipe length	Main pipe		m [ft]	5 [16-3/8]	
		Branch pipe			10 [32-3/4]	
		Total pipe length			65 [213-1/4]	
	Fan speed		-	Hi		
Refrigerant charge		kg [lbs-oz]	22.5 [50]			
Heat source unit	Current		A	58.3		
	Voltage		V	230		
	Compressor frequency		Hz	67	67	
LEV opening	Indoor unit		Pulse	406/406/406/406/406/406		
	SC (LEV1)			0	0	
	LEV6			126	126	
	LEV7			3000	3000	
Pressure switch	High pressure (after O/S)/ Low pressure (before accumulator)		MPa [psi]	2.54/0.80 [368/116]	2.54/0.80 [368/116]	
Sectional temperatures	Heat source unit	Discharge (TH4)		°C [°F]	80 [176]	80 [176]
		Heat exchanger outlet			5 [41]	5 [41]
		Accumulator inlet			4 [39]	4 [39]
		Accumulator outlet			4 [39]	4 [39]
		Compressor inlet			4 [39]	4 [39]
		Compressor shell bottom			40 [104]	40 [104]
	Indoor unit	LEV inlet		36 [97]		
		Heat exchanger inlet		70 [158]		

Item			2-unit combination			
			PQHY-P312TSLMU-A1			
			PQHY-P168TLMU-A1	PQHY-P144TLMU-A1		
Operating conditions	Indoor temperature		DB/WB	21.1°C/[70°F/-]		
	Heat source water temperature		°C [°F]	21.1[70]		
	Heat source water flow rate		m ³ /h G/h gpm	7.20 [1902] [31.7]	7.20 [1902] [31.7]	
	Indoor unit	No. of connected units		Unit	6	
		No. of units in operation			6	
		Model			54/54/54/54/48/48	
	Pipe length	Main pipe		m [ft]	5 [16-3/8]	
		Branch pipe			10 [32-3/4]	
		Total pipe length			65 [213-1/4]	
	Fan speed		-	Hi		
Refrigerant charge		kg [lbs-oz]	22.5 [50]			
Heat source unit	Current		A	66.9		
	Voltage		V	230		
	Compressor frequency		Hz	73	73	
LEV opening	Indoor unit		Pulse	414/414/414/414/406/406		
	SC (LEV1)			0	0	
	LEV6			145	145	
	LEV7			3000	3000	
Pressure switch	High pressure (after O/S)/ Low pressure (before accumulator)		MPa [psi]	2.58/0.80 [374/116]	2.58/0.80 [374/116]	
Sectional temperatures	Heat source unit	Discharge (TH4)		80 [176]	80 [176]	
		Heat exchanger outlet		5 [41]	5 [41]	
		Accumulator inlet		4 [39]	4 [39]	
		Accumulator outlet		4 [39]	4 [39]	
		Compressor inlet		4 [39]	4 [39]	
		Compressor shell bottom		40 [104]	40 [104]	
	Indoor unit	LEV inlet		36 [97]		
		Heat exchanger inlet		70 [158]		

Item			2-unit combination			
			PQHY-P336TSLMU-A1			
			PQHY-P168TLMU-A1	PQHY-P168TLMU-A1		
Operating conditions	Indoor temperature		DB/WB	21.1°C/[70°F/-]		
	Heat source water temperature		°C [°F]	21.1[70]		
	Heat source water flow rate		m ³ /h G/h gpm	7.20 [1902] [31.7]	7.20 [1902] [31.7]	
	Indoor unit	No. of connected units		Unit	7	
		No. of units in operation			7	
		Model			48/48/48/48/48/48/48	
	Pipe length	Main pipe		m [ft]	5 [16-3/8]	
		Branch pipe			10 [32-3/4]	
		Total pipe length			65 [213-1/4]	
	Fan speed		-	Hi		
Refrigerant charge		kg [lbs-oz]	23.5 [52]			
Heat source unit	Current		A	76.7		
	Voltage		V	230		
	Compressor frequency		Hz	78	78	
LEV opening	Indoor unit		Pulse	406/406/406/406/406/406/406		
	SC (LEV1)			0	0	
	LEV6			164	164	
	LEV7			3000	3000	
Pressure switch	High pressure (after O/S)/ Low pressure (before accumulator)		MPa [psi]	2.62/0.80 [380/116]	2.62/0.80 [380/116]	
Sectional temperatures	Heat source unit	Discharge (TH4)		81 [178]	81 [178]	
		Heat exchanger outlet		5 [41]	5 [41]	
		Accumulator inlet		4 [39]	4 [39]	
		Accumulator outlet		4 [39]	4 [39]	
		Compressor inlet		4 [39]	4 [39]	
		Compressor shell bottom		40 [104]	40 [104]	
	Indoor unit	LEV inlet		37 [99]		
		Heat exchanger inlet		70 [158]		

Item			2-unit combination			
			PQHY-P360TSLMU-A1			
			PQHY-P192TLMU-A1	PQHY-P168TLMU-A1		
Operating conditions	Indoor temperature		DB/WB	21.1°C/[70°F/-]		
	Heat source water temperature		°C [°F]	21.1[70]		
	Heat source water flow rate		m ³ /h G/h gpm	7.20 [1902] [31.7]	7.20 [1902] [31.7]	
	Indoor unit	No. of connected units		Unit	7	
		No. of units in operation			7	
		Model			54/54/54/54/48/48/48	
	Pipe length	Main pipe		m [ft]	5 [16-3/8]	
		Branch pipe			10 [32-3/4]	
		Total pipe length			75 [246-1/16]	
	Fan speed		-	Hi		
Refrigerant charge		kg [lbs-oz]	23.8 [53]			
Heat source unit	Current		A	84.1		
	Voltage		V	230		
	Compressor frequency		Hz	84	84	
LEV opening	Indoor unit		Pulse	414/414/414/414/406/406/406		
	SC (LEV1)			0	0	
	LEV6			183	183	
	LEV7			3000	3000	
Pressure switch	High pressure (after O/S)/ Low pressure (before accumulator)		MPa [psi]	2.63/0.80 [381/116]	2.63/0.80 [381/116]	
Sectional temperatures	Heat source unit	Discharge (TH4)		81 [178]	81 [178]	
		Heat exchanger outlet		5 [41]	5 [41]	
		Accumulator inlet		4 [39]	4 [39]	
		Accumulator outlet		4 [39]	4 [39]	
		Compressor inlet		4 [39]	4 [39]	
		Compressor shell bottom		40 [104]	40 [104]	
	Indoor unit	LEV inlet		37 [99]		
		Heat exchanger inlet		70 [158]		

3. Single unit <PQRY>
(1) Cooling only operation

Item			Heat source unit model		
			PQRY-P72TLMU-A1	PQRY-P96TLMU-A1	
Model name of BC controller			CMB-P104NU-G1	CMB-P104NU-G1	
Operating conditions	Indoor temperature	DB/WB	26.7°C/19.4°C [80 °F/67 °F]	26.7°C/19.4°C [80 °F/67 °F]	
	Heat source water temperature	°C [°F]	29.4[85]	29.4[85]	
	Heat source water flow rate	m ³ /h [G/h] [gpm]	5.76 [1522] [25.4]	5.76 [1522] [25.4]	
	Indoor unit	No. of connected units	Unit	2	2
		No. of units in operation		2	2
		Model		-	36/36
	Pipe length	Main pipe	m [ft]	5 [16-3/8]	5 [16-3/8]
		Branch pipe		10 [32-3/4]	10 [32-3/4]
		Total pipe length		25 [82]	25 [82]
	Fan speed	-	Hi	Hi	
Refrigerant charge	kg [lbs-oz]	11.8 [27]	13.0 [29]		
Heat source unit	Current	A	17.7	23.3	
	Voltage	V	230	230	
	Compressor frequency	Hz	66	90	
LEV opening	Indoor unit	Pulse	325/325	387/387	
	BC controller (1/2/3)		2000/-/160	2000/-/170	
	LEV6		41	41	
	LEV7		3000	3000	
Pressure switch	High pressure (after O/S)/ Low pressure (before accumulator)	MPa [psi]	2.20/0.81 [319/117]	2.27/0.81 [329/117]	
	BC controller on the liquid side (PS1)/Intermediate part (PS3)		2.10/2.10 [305/305]	2.17/2.17 [315/315]	
Sectional temperatures	Heat source unit	Discharge (TH4)	65 [149]	65 [149]	
		Heat exchanger outlet	33 [91]	34 [93]	
		Accumulator inlet	8 [46]	8 [46]	
		Accumulator outlet	8 [46]	8 [46]	
		Compressor inlet	19 [66]	19 [66]	
		Compressor shell bottom	47 [117]	40 [104]	
	Indoor unit	LEV inlet	19 [66]	19 [66]	
		Heat exchanger outlet	6 [43]	6 [43]	

Item			Heat source unit model			
			PQRY-P120TLMU-A1	PQRY-P144TLMU-A1		
Model name of BC controller			CMB-P104NU-G1	CMB-P108NU-GA1		
Operating conditions	Indoor temperature		DB/WB	26.7°C/19.4°C [80 °F/67 °F]	26.7°C/19.4°C [80 °F/67 °F]	
	Heat source water temperature		°C [°F]	29.4[85]	29.4[85]	
	Heat source water flow rate		m ³ /h [G/h] [gpm]	5.76 [1522] [25.4]	7.20 [1902] [31.7]	
	Indoor unit	No. of connected units		Unit	3	4
		No. of units in operation			3	4
		Model		-	36/36/48	36/36/36/36
	Pipe length	Main pipe		m [ft]	5 [16-3/8]	5 [16-3/8]
		Branch pipe			10 [32-3/4]	10 [32-3/4]
		Total pipe length			35 [115]	45 [148]
	Fan speed		-	Hi	Hi	
Refrigerant charge		kg [lbs-oz]	13.6 [30]	16.3 [36]		
Heat source unit	Current		A	23.8	24.4	
	Voltage		V	230	230	
	Compressor frequency		Hz	114	82	
LEV opening	Indoor unit		Pulse	325/325/387	325/325/325/325	
	BC controller (1/2/3)			2000/-/180	2000/2000/210	
	LEV6			41	41	
	LEV7			3000	3000	
Pressure switch	High pressure (after O/S)/ Low pressure (before accumulator)		MPa [psi]	2.30/0.81 [334/117]	2.36/0.81 [342/117]	
	BC controller on the liquid side (PS1)/Intermediate part (PS3)			2.20/2.20 [319/319]	2.26/2.26 [328/328]	
Sectional temperatures	Heat source unit	Discharge (TH4)		°C [°F]	65 [149]	65 [149]
		Heat exchanger outlet			35 [95]	36 [97]
		Accumulator inlet			8 [46]	8 [46]
		Accumulator outlet			8 [46]	8 [46]
		Compressor inlet			19 [66]	19 [66]
		Compressor shell bottom			42 [108]	42 [108]
	Indoor unit	LEV inlet			19 [66]	19 [66]
		Heat exchanger outlet			6 [43]	6 [43]

Item			Heat source unit model			
			PQRY-P168TLMU-A1	PQRY-P192TLMU-A1		
Model name of BC controller			CMB-P108NU-GA1	CMB-P108NU-GA1		
Operating conditions	Indoor temperature		DB/WB	26.7°C/19.4°C [80 °F/67 °F]	26.7°C/19.4°C [80 °F/67 °F]	
	Heat source water temperature		°C [°F]	29.4[85]	29.4[85]	
	Heat source water flow rate		m ³ /h [G/h] [gpm]	7.20 [1902] [31.7]	7.20 [1902] [31.7]	
	Indoor unit	No. of connected units		Unit	4	4
		No. of units in operation			4	4
		Model		-	36/36/48/48	48/48/48/48
	Pipe length	Main pipe		m [ft]	5 [16-3/8]	5 [16-3/8]
		Branch pipe			10 [32-3/4]	10 [32-3/4]
		Total pipe length			45 [148]	45 [148]
	Fan speed		-	Hi	Hi	
Refrigerant charge		kg [lbs-oz]	19.1 [43]	20.6 [46]		
Heat source unit	Current		A	33.6	41.9	
	Voltage		V	230	230	
	Compressor frequency		Hz	97	112	
LEV opening	Indoor unit		Pulse	325/325/387/387	387/387/387/387	
	BC controller (1/2/3)			2000/2000/210	2000/2000/220	
	LEV6			41	41	
	LEV7			3000	3000	
Pressure switch	High pressure (after O/S)/ Low pressure (before accumulator)		MPa [psi]	2.48/0.81 [360/117]	2.56/0.81 [371/117]	
	BC controller on the liquid side (PS1)/Intermediate part (PS3)			2.38/2.38 [345/345]	2.46/2.46 [357/357]	
Sectional temperatures	Heat source unit	Discharge (TH4)		65 [149]	65 [149]	
		Heat exchanger outlet		38 [100]	39 [102]	
		Accumulator inlet		8 [46]	8 [46]	
		Accumulator outlet		8 [46]	8 [46]	
		Compressor inlet		19 [66]	19 [66]	
		Compressor shell bottom		42 [108]	42 [108]	
	Indoor unit	LEV inlet		19 [66]	19 [66]	
		Heat exchanger outlet		6 [43]	6 [43]	

Item			Heat source unit model			
			PQRY-P216TLMU-A1	PQRY-P240TLMU-A1		
Model name of BC controller			CMB-P1013NU-GA1	CMB-P1013NU-GA1		
Operating conditions	Indoor temperature		DB/WB	26.7°C/19.4°C [80 °F/67 °F]	26.7°C/19.4°C [80 °F/67 °F]	
	Heat source water temperature		°C [°F]	29.4[85]	29.4[85]	
	Heat source water flow rate		m ³ /h [G/h] [gpm]	11.52 [3044] [50.7]	11.52 [3044] [50.7]	
	Indoor unit	No. of connected units		Unit	5	6
		No. of units in operation			5	6
		Model		-	36/36/48/48/48	36/36/36/36/48/48
	Pipe length	Main pipe		m [ft]	5 [16-3/8]	5 [16-3/8]
		Branch pipe			10 [32-3/4]	10 [32-3/4]
		Total pipe length			65 [213-1/4]	65 [213-1/4]
	Fan speed		-	Hi	Hi	
Refrigerant charge		kg [lbs-oz]	28.9 [64]	28.9 [64]		
Heat source unit	Current		A	53.6	58.9	
	Voltage		V	230	230	
	Compressor frequency		Hz	112	120	
LEV opening	Indoor unit		Pulse	325/325/387/387/387	325/325/325/325/387/387	
	BC controller (1/2/3)			2000/2000/230	2000/2000/240	
	LEV6			41	41	
	LEV7			3000	3000	
Pressure switch	High pressure (after O/S)/ Low pressure (before accumulator)		MPa [psi]	2.51/0.81 [364/117]	2.62/0.81 [380/117]	
	BC controller on the liquid side (PS1)/Intermediate part (PS3)			2.41/2.41 [350/350]	2.52/2.52 [365/365]	
Sectional temperatures	Heat source unit	Discharge (TH4)		°C [°F]	65 [149]	65 [149]
		Heat exchanger outlet			39 [102]	40 [104]
		Accumulator inlet			8 [46]	8 [46]
		Accumulator outlet			8 [46]	8 [46]
		Compressor inlet			19 [66]	19 [66]
		Compressor shell bottom			42 [108]	42 [108]
	Indoor unit	LEV inlet			19 [66]	19 [66]
		Heat exchanger outlet			6 [43]	6 [43]

(2) Heating only operation

Item			Heat source unit model			
			PQRY-P72TLMU-A1	PQRY-P96TLMU-A1		
Model name of BC controller			CMB-P104NU-G1	CMB-P104NU-G1		
Operating conditions	Indoor temperature		DB/WB	21.1°C/- [70 °F/-]	21.1°C/- [70 °F/-]	
	Heat source water temperature		°C [°F]	21.1[70]	21.1[70]	
	Heat source water flow rate		m ³ /h [G/h] [gpm]	5.76 [1522] [25.4]	5.76 [1522] [25.4]	
	Indoor unit	No. of connected units		Unit	2	2
		No. of units in operation			2	2
		Model			-	36/36
	Pipe length	Main pipe		m [ft]	5 [16-3/8]	5 [16-3/8]
		Branch pipe			10 [32-3/4]	10 [32-3/4]
		Total pipe length			25 [82]	25 [82]
	Fan speed		-	Hi	Hi	
Refrigerant charge		kg [lbs-oz]	11.8 [27]	13.0 [29]		
Heat source unit	Current		A	18.6	25.2	
	Voltage		V	230	230	
	Compressor frequency		Hz	60	72	
LEV opening	Indoor unit		Pulse	332/332	406/406	
	BC controller (1/2/3)			110/-/520	110/-/590	
	LEV6			68	84	
	LEV7			41	41	
Pressure switch	High pressure (after O/S)/ Low pressure (before accumulator)		MPa [psi]	2.64/0.80 [383/116]	2.90/0.80 [421/116]	
	BC controller on the liquid side (PS1)/Intermediate part (PS3)			2.61/2.29 [379/332]	2.87/2.55 [416/370]	
Sectional temperatures	Heat source unit	Discharge (TH4)		73 [163]	80 [176]	
		Heat exchanger outlet		5 [41]	5 [41]	
		Accumulator inlet		4 [39]	4 [39]	
		Accumulator outlet		4 [39]	4 [39]	
		Compressor inlet		4 [39]	4 [39]	
		Compressor shell bottom		40 [104]	40 [104]	
	Indoor unit	LEV inlet		37 [99]	38 [100]	
		Heat exchanger inlet		70 [158]	70 [158]	

Item			Heat source unit model			
			PQRY-P120TLMU-A1	PQRY-P144TLMU-A1		
Model name of BC controller			CMB-P104NU-G1	CMB-P108NU-GA1		
Operating conditions	Indoor temperature		DB/WB	21.1°C/- [70 °F/-]	21.1°C/- [70 °F/-]	
	Heat source water temperature		°C [°F]	21.1[70]	21.1[70]	
	Heat source water flow rate		m ³ /h [G/h] [gpm]	5.76 [1522] [25.4]	7.20 [1902] [31.7]	
	Indoor unit	No. of connected units		Unit	3	4
		No. of units in operation			3	4
		Model			-	36/36/48
	Pipe length	Main pipe		m [ft]	5 [16-3/8]	5 [16-3/8]
		Branch pipe			10 [32-3/4]	10 [32-3/4]
		Total pipe length			35 [115]	45 [148]
	Fan speed		-	Hi	Hi	
Refrigerant charge		kg [lbs-oz]	13.6 [30]	16.3 [36]		
Heat source unit	Current		A	28.3	29.1	
	Voltage		V	230	230	
	Compressor frequency		Hz	90	75	
LEV opening	Indoor unit		Pulse	332/332/406	332/332/332/332	
	BC controller (1/2/3)			110/-/660	110/110/870	
	LEV6			122	136	
	LEV7			41	41	
Pressure switch	High pressure (after O/S)/ Low pressure (before accumulator)		MPa [psi]	2.68/0.80 [389/116]	2.54/0.80 [368/116]	
	BC controller on the liquid side (PS1)/Intermediate part (PS3)			2.64/2.32 [383/336]	2.51/2.19 [364/318]	
Sectional temperatures	Heat source unit	Discharge (TH4)		81 [178]	77 [171]	
		Heat exchanger outlet		5 [41]	5 [41]	
		Accumulator inlet		4 [39]	4 [39]	
		Accumulator outlet		4 [39]	4 [39]	
		Compressor inlet		4 [39]	4 [39]	
		Compressor shell bottom		40 [104]	40 [104]	
	Indoor unit	LEV inlet		39 [102]	36 [97]	
		Heat exchanger inlet		70 [158]	70 [158]	

Item			Heat source unit model			
			PQRY-P168TLMU-A1	PQRY-P192TLMU-A1		
Model name of BC controller			CMB-P108NU-GA1	CMB-P108NU-GA1		
Operating conditions	Indoor temperature		DB/WB	21.1°C/- [70 °F/-]	21.1°C/- [70 °F/-]	
	Heat source water temperature		°C [°F]	21.1[70]	21.1[70]	
	Heat source water flow rate		m ³ /h [G/h] [gpm]	7.20 [1902] [31.7]	7.20 [1902] [31.7]	
	Indoor unit	No. of connected units		Unit	4	4
		No. of units in operation			4	4
		Model			-	36/36/48/48
	Pipe length	Main pipe		m [ft]	5 [16-3/8]	5 [16-3/8]
		Branch pipe			10 [32-3/4]	10 [32-3/4]
		Total pipe length			45 [148]	45 [148]
	Fan speed		-	Hi	Hi	
Refrigerant charge		kg [lbs-oz]	19.1 [43]	20.6 [46]		
Heat source unit	Current		A	40.0	49.9	
	Voltage		V	230	230	
	Compressor frequency		Hz	82	90	
LEV opening	Indoor unit		Pulse	332/332/406/406	406/406/406/406	
	BC controller (1/2/3)			110/110/870	110/110/980	
	LEV6			152	168	
	LEV7			41	41	
Pressure switch	High pressure (after O/S)/ Low pressure (before accumulator)		MPa [psi]	2.62/0.80 [380/116]	2.64/0.80 [383/116]	
	BC controller on the liquid side (PS1)/Intermediate part (PS3)			2.59/2.27 [376/329]	2.61/2.29 [379/332]	
Sectional temperatures	Heat source unit	Discharge (TH4)		77 [171]	80 [176]	
		Heat exchanger outlet		5 [41]	5 [41]	
		Accumulator inlet		4 [39]	4 [39]	
		Accumulator outlet		4 [39]	4 [39]	
		Compressor inlet		4 [39]	4 [39]	
		Compressor shell bottom		40 [104]	40 [104]	
	Indoor unit	LEV inlet		37 [99]	37 [99]	
		Heat exchanger inlet		70 [158]	70 [158]	

Item			Heat source unit model			
			PQRY-P216TLMU-A1	PQRY-P240TLMU-A1		
Model name of BC controller			CMB-P1013NU-GA1	CMB-P1013NU-GA1		
Operating conditions	Indoor temperature		DB/WB	21.1°C/- [70 °F/-]	21.1°C/- [70 °F/-]	
	Heat source water temperature		°C [°F]	21.1[70]	21.1[70]	
	Heat source water flow rate		m ³ /h [G/h] [gpm]	11.52 [3044] [50.7]	11.52 [3044] [50.7]	
	Indoor unit	No. of connected units		Unit	5	6
		No. of units in operation			5	6
		Model		-	36/36/48/48/48	36/36/36/36/48/48
	Pipe length	Main pipe		m [ft]	5 [16-3/8]	5 [16-3/8]
		Branch pipe			10 [32-3/4]	10 [32-3/4]
		Total pipe length			65 [213-1/4]	65 [213-1/4]
	Fan speed		-	Hi	Hi	
Refrigerant charge		kg [lbs-oz]	28.9 [64]	28.9 [64]		
Heat source unit	Current		A	63.8	70.1	
	Voltage		V	230	230	
	Compressor frequency		Hz	93	103	
LEV opening	Indoor unit		Pulse	332/332/406/406/406	332/332/332/332/406/406	
	BC controller (1/2/3)			110/110/1050	110/110/1120	
	LEV6			206	244	
	LEV7			41	41	
Pressure switch	High pressure (after O/S)/ Low pressure (before accumulator)		MPa [psi]	2.64/0.80 [383/116]	2.69/0.80 [390/116]	
	BC controller on the liquid side (PS1)/Intermediate part (PS3)			2.61/2.29 [379/332]	2.65/2.33 [384/338]	
Sectional temperatures	Heat source unit	Discharge (TH4)		81 [178]	81 [178]	
		Heat exchanger outlet		5 [41]	5 [41]	
		Accumulator inlet		4 [39]	4 [39]	
		Accumulator outlet		4 [39]	4 [39]	
		Compressor inlet		4 [39]	4 [39]	
		Compressor shell bottom		40 [104]	40 [104]	
	Indoor unit	LEV inlet		37 [99]	38 [100]	
		Heat exchanger inlet		70 [158]	70 [158]	

4. 2-unit combination <PQR>

(1) Cooling only operation

Item			2-unit combination			
			PQR-P144TSLMU-A1			
			PQR-P72TLMU-A1	PQR-P72TLMU-A1		
Model name of BC controller			CMB-P108NU-GA1			
Operating conditions	Indoor temperature		DB/WB	26.7°C/19.4°C [80 °F/67 °F]		
	Heat source water temperature		°C [°F]	29.4 [85]		
	Heat source water flow rate		m ³ /h G/h gpm	5.76 [1522] [25.4]	5.76 [1522] [25.4]	
	Indoor unit	No. of connected units		Unit	4	
		No. of units in operation			4	
		Model			36/36/36/36	
	Pipe length	Main pipe		m [ft]	5 [16-3/8]	
		Branch pipe			10 [32-3/4]	
		Total pipe length			45 [148]	
	Fan speed		-	Hi		
Refrigerant charge		kg [lbs-oz]	20.3 [45]			
Heat source unit	Current		A	42.3		
	Voltage		V	230		
	Compressor frequency		Hz	66	66	
LEV opening	Indoor unit		Pulse	325/325/325/325		
	BC controller (1/2/3)			2000/2000/210		
	LEV6			41	41	
	LEV7			3000	3000	
Pressure switch	High pressure (after O/S)/ Low pressure (before accumulator)		MPa [psi]	2.20/0.81 [319/117]	2.20/0.81 [319/117]	
	BC controller on the liquid side (PS1)/Intermediate part (PS3)			2.10/2.10 [305/305]		
Sectional temperatures	Heat source unit	Discharge (TH4)		65 [149]	65 [149]	
		Heat exchanger outlet		33 [91]	33 [91]	
		Accumulator inlet		8 [46]	8 [46]	
		Accumulator outlet		8 [46]	8 [46]	
		Compressor inlet		19 [66]	19 [66]	
		Compressor shell bottom		47 [117]	47 [117]	
	Indoor unit	LEV inlet		19 [66]		
		Heat exchanger outlet		6 [43]		

Item			2-unit combination			
			PQRY-P168TSLMU-A1			
			PQRY-P96TLMU-A1	PQRY-P72TLMU-A1		
Model name of BC controller			CMB-P108NU-GA1			
Operating conditions	Indoor temperature		DB/WB	26.7°C/19.4°C [80 °F/67 °F]		
	Heat source water temperature		°C [°F]	29.4 [85]		
	Heat source water flow rate		m ³ /h G/h gpm	5.76 [1522] [25.4]	5.76 [1522] [25.4]	
	Indoor unit	No. of connected units		Unit	4	
		No. of units in operation			4	
		Model		-	36/36/48/48	
	Pipe length	Main pipe		m [ft]	5 [16-3/8]	
		Branch pipe			10 [32-3/4]	
		Total pipe length			45 [148]	
	Fan speed		-	Hi		
Refrigerant charge		kg [lbs-oz]	23.1 [51]			
Heat source unit	Current		A	42.3		
	Voltage		V	230		
	Compressor frequency		Hz	78	78	
LEV opening	Indoor unit		Pulse	325/325/387/387		
	BC controller (1/2/3)			2000/2000/210		
	LEV6			41	41	
	LEV7			3000	3000	
Pressure switch	High pressure (after O/S)/ Low pressure (before accumulator)		MPa [psi]	2.23/0.81 [323/117]	2.23/0.81 [323/117]	
	BC controller on the liquid side (PS1)/Intermediate part (PS3)			2.13/2.13 [309/309]		
Sectional temperatures	Heat source unit	Discharge (TH4)		65 [149]	65 [149]	
		Heat exchanger outlet		33 [91]	33 [91]	
		Accumulator inlet		8 [46]	8 [46]	
		Accumulator outlet		8 [46]	8 [46]	
		Compressor inlet		19 [66]	19 [66]	
		Compressor shell bottom		40 [104]	47 [117]	
	Indoor unit	LEV inlet		19 [66]		
		Heat exchanger outlet		6 [43]		

Item			2-unit combination			
			PQRY-P192TSLMU-A1			
			PQRY-P96TLMU-A1	PQRY-P96TLMU-A1		
Model name of BC controller			CMB-P108NU-GA1			
Operating conditions	Indoor temperature		DB/WB	26.7°C/19.4°C [80 °F/67 °F]		
	Heat source water temperature		°C [°F]	29.4 [85]		
	Heat source water flow rate		m ³ /h G/h gpm	5.76 [1522] [25.4]	5.76 [1522] [25.4]	
	Indoor unit	No. of connected units		Unit	4	
		No. of units in operation			4	
		Model		-	48/48/48/48	
	Pipe length	Main pipe		m [ft]	5 [16-3/8]	
		Branch pipe			10 [32-3/4]	
		Total pipe length			45 [148]	
	Fan speed		-	Hi		
Refrigerant charge		kg [lbs-oz]	24.6 [54]			
Heat source unit	Current		A	51.8		
	Voltage		V	230		
	Compressor frequency		Hz	90	90	
LEV opening	Indoor unit		Pulse	387/387/387/387		
	BC controller (1/2/3)			2000/2000/220		
	LEV6			41	41	
	LEV7			3000	3000	
Pressure switch	High pressure (after O/S)/ Low pressure (before accumulator)		MPa [psi]	2.27/0.81 [329/117]	2.27/0.81 [329/117]	
	BC controller on the liquid side (PS1)/Intermediate part (PS3)			2.17/2.17 [315/315]		
Sectional temperatures	Heat source unit	Discharge (TH4)		65 [149]	65 [149]	
		Heat exchanger outlet		34 [93]	34 [93]	
		Accumulator inlet		8 [46]	8 [46]	
		Accumulator outlet		8 [46]	8 [46]	
		Compressor inlet		19 [66]	19 [66]	
		Compressor shell bottom		40 [104]	40 [104]	
	Indoor unit	LEV inlet		19 [66]		
		Heat exchanger outlet		6 [43]		

Item			2-unit combination			
			PQRY-P216TSLMU-A1			
			PQRY-P120TLMU-A1	PQRY-P96TLMU-A1		
Model name of BC controller			CMB-P1013NU-GA1			
Operating conditions	Indoor temperature		DB/WB	26.7°C/19.4°C [80 °F/67 °F]		
	Heat source water temperature		°C [°F]	29.4 [85]		
	Heat source water flow rate		m ³ /h G/h gpm	5.76 [1522] [25.4]	5.76 [1522] [25.4]	
	Indoor unit	No. of connected units		Unit	5	
		No. of units in operation			5	
		Model		-	36/36/48/48/48	
	Pipe length	Main pipe		m [ft]	5 [16-3/8]	
		Branch pipe			10 [32-3/4]	
		Total pipe length			65 [213-1/4]	
	Fan speed		-	Hi		
Refrigerant charge		kg [lbs-oz]	26.2 [58]			
Heat source unit	Current		A	52.2		
	Voltage		V	230		
	Compressor frequency		Hz	98	98	
LEV opening	Indoor unit		Pulse	325/325/387/387/387		
	BC controller (1/2/3)			2000/2000/230		
	LEV6			41	41	
	LEV7			3000	3000	
Pressure switch	High pressure (after O/S)/ Low pressure (before accumulator)		MPa [psi]	2.28/0.81 [331/117]	2.28/0.81 [331/117]	
	BC controller on the liquid side (PS1)/Intermediate part (PS3)			2.18/2.18 [316/316]		
Sectional temperatures	Heat source unit	Discharge (TH4)		65 [149]	65 [149]	
		Heat exchanger outlet		35 [95]	35 [95]	
		Accumulator inlet		8 [46]	8 [46]	
		Accumulator outlet		8 [46]	8 [46]	
		Compressor inlet		19 [66]	19 [66]	
		Compressor shell bottom		42 [108]	40 [104]	
	Indoor unit	LEV inlet		19 [66]		
		Heat exchanger outlet		6 [43]		

Item			2-unit combination			
			PQRY-P240TSLMU-A1			
			PQRY-P120TLMU-A1	PQRY-P120TLMU-A1		
Model name of BC controller			CMB-P1013NU-GA1			
Operating conditions	Indoor temperature		DB/WB	26.7°C/19.4°C [80 °F/67 °F]		
	Heat source water temperature		°C [°F]	29.4 [85]		
	Heat source water flow rate		m ³ /h G/h gpm	5.76 [1522] [25.4]	5.76 [1522] [25.4]	
	Indoor unit	No. of connected units		Unit	6	
		No. of units in operation			6	
		Model		-	36/36/36/36/48/48	
	Pipe length	Main pipe		m [ft]	5 [16-3/8]	
		Branch pipe			10 [32-3/4]	
		Total pipe length			65 [213-1/4]	
	Fan speed		-	Hi		
Refrigerant charge		kg [lbs-oz]	26.2 [58]			
Heat source unit	Current		A	56.9		
	Voltage		V	230		
	Compressor frequency		Hz	105	105	
LEV opening	Indoor unit		Pulse	325/325/325/325/387/387		
	BC controller (1/2/3)			2000/2000/240		
	LEV6			41	41	
	LEV7			3000	3000	
Pressure switch	High pressure (after O/S)/ Low pressure (before accumulator)		MPa [psi]	2.30/0.81 [334/117]	2.30/0.81 [334/117]	
	BC controller on the liquid side (PS1)/Intermediate part (PS3)		2.20/2.20 [319/319]			
Sectional temperatures	Heat source unit	Discharge (TH4)		65 [149]	65 [149]	
		Heat exchanger outlet		35 [95]	35 [95]	
		Accumulator inlet		8 [46]	8 [46]	
		Accumulator outlet		8 [46]	8 [46]	
		Compressor inlet		19 [66]	19 [66]	
		Compressor shell bottom		42 [108]	42 [108]	
	Indoor unit	LEV inlet		19 [66]		
		Heat exchanger outlet		6 [43]		

Item			2-unit combination			
			PQRY-P288TSLMU-A1			
			PQRY-P144TLMU-A1	PQRY-P144TLMU-A1		
Model name of BC controller			CMB-P1016NU-HA1			
Operating conditions	Indoor temperature		DB/WB	26.7°C/19.4°C [80 °F/67 °F]		
	Heat source water temperature		°C [°F]	29.4 [85]		
	Heat source water flow rate		m ³ /h G/h gpm	7.20 [1902] [31.7]	7.20 [1902] [31.7]	
	Indoor unit	No. of connected units		Unit	6	
		No. of units in operation			6	
		Model		-	48/48/48/48/48/48	
	Pipe length	Main pipe		m [ft]	5 [16-3/8]	
		Branch pipe			10 [32-3/4]	
		Total pipe length			65 [213-1/4]	
	Fan speed		-	Hi		
Refrigerant charge		kg [lbs-oz]	22.5 [50]			
Heat source unit	Current		A	56.9		
	Voltage		V	230		
	Compressor frequency		Hz	84	84	
LEV opening	Indoor unit		Pulse	387/387/387/387/387/387		
	BC controller (1/2/3)			2000/2000/290		
	LEV6			41	41	
	LEV7			3000	3000	
Pressure switch	High pressure (after O/S)/ Low pressure (before accumulator)		MPa [psi]	2.36/0.81 [342/117]	2.36/0.81 [342/117]	
	BC controller on the liquid side (PS1)/Intermediate part (PS3)			2.26/2.26 [328/328]		
Sectional temperatures	Heat source unit	Discharge (TH4)		65 [149]	65 [149]	
		Heat exchanger outlet		36 [93]	36 [93]	
		Accumulator inlet		8 [46]	8 [46]	
		Accumulator outlet		8 [46]	8 [46]	
		Compressor inlet		19 [66]	19 [66]	
		Compressor shell bottom		40 [104]	40 [104]	
	Indoor unit	LEV inlet		19 [66]		
		Heat exchanger outlet		6 [43]		

Item			2-unit combination			
			PQRY-P312TSLMU-A1			
			PQRY-P168TLMU-A1	PQRY-P144TLMU-A1		
Model name of BC controller			CMB-P1016NU-HA1			
Operating conditions	Indoor temperature		DB/WB	26.7°C/19.4°C [80 °F/67 °F]		
	Heat source water temperature		°C [°F]	29.4 [85]		
	Heat source water flow rate		m ³ /h G/h gpm	7.20 [1902] [31.7]	7.20 [1902] [31.7]	
	Indoor unit	No. of connected units		Unit	6	
		No. of units in operation			6	
		Model		-	54/54/54/54/48/48	
	Pipe length	Main pipe		m [ft]	5 [16-3/8]	
		Branch pipe			10 [32-3/4]	
		Total pipe length			65 [213-1/4]	
	Fan speed		-	Hi		
Refrigerant charge		kg [lbs-oz]	22.5 [50]			
Heat source unit	Current		A	65.2		
	Voltage		V	230		
	Compressor frequency		Hz	89	89	
LEV opening	Indoor unit		Pulse	395/395/395/387/387/387		
	BC controller (1/2/3)			2000/2000/290		
	LEV6			41	41	
	LEV7			3000	3000	
Pressure switch	High pressure (after O/S)/ Low pressure (before accumulator)		MPa [psi]	2.42/0.81 [351/117]	2.42/0.81 [351/117]	
	BC controller on the liquid side (PS1)/Intermediate part (PS3)			2.32/2.32 [336/336]		
Sectional temperatures	Heat source unit	Discharge (TH4)		65 [149]	65 [149]	
		Heat exchanger outlet		37 [93]	37 [93]	
		Accumulator inlet		8 [46]	8 [46]	
		Accumulator outlet		8 [46]	8 [46]	
		Compressor inlet		19 [66]	19 [66]	
		Compressor shell bottom		40 [104]	40 [104]	
	Indoor unit	LEV inlet		19 [66]		
		Heat exchanger outlet		6 [43]		

Item			2-unit combination			
			PQRY-P336TSLMU-A1			
			PQRY-P168TLMU-A1	PQRY-P168TLMU-A1		
Model name of BC controller			CMB-P1016NU-HA1			
Operating conditions	Indoor temperature		DB/WB	26.7°C/19.4°C [80 °F/67 °F]		
	Heat source water temperature		°C [°F]	29.4 [85]		
	Heat source water flow rate		m ³ /h G/h gpm	7.20 [1902] [31.7]	7.20 [1902] [31.7]	
	Indoor unit	No. of connected units		Unit	7	
		No. of units in operation			7	
		Model		-	48/48/48/48/48/48/48	
	Pipe length	Main pipe		m [ft]	5 [16-3/8]	
		Branch pipe			10 [32-3/4]	
		Total pipe length			65 [213-1/4]	
	Fan speed		-	Hi		
Refrigerant charge		kg [lbs-oz]	23.5 [52]			
Heat source unit	Current		A	74.8		
	Voltage		V	230		
	Compressor frequency		Hz	93	93	
LEV opening	Indoor unit		Pulse	387/387/387/387/387/387/387		
	BC controller (1/2/3)			2000/2000/290		
	LEV6			41	41	
	LEV7			3000	3000	
Pressure switch	High pressure (after O/S)/ Low pressure (before accumulator)		MPa [psi]	2.48/0.81 [360/117]	2.48/0.81 [360/117]	
	BC controller on the liquid side (PS1)/Intermediate part (PS3)			2.38/2.38 [345/345]		
Sectional temperatures	Heat source unit	Discharge (TH4)		65 [149]	65 [149]	
		Heat exchanger outlet		38 [95]	38 [95]	
		Accumulator inlet		8 [46]	8 [46]	
		Accumulator outlet		8 [46]	8 [46]	
		Compressor inlet		19 [66]	19 [66]	
		Compressor shell bottom		40 [104]	40 [104]	
	Indoor unit	LEV inlet		19 [66]		
		Heat exchanger outlet		6 [43]		

(2) Heating only operation

Item			2-unit combination			
			PQRY-P144TSLMU-A1			
			PQRY-P72TLMU-A1	PQRY-P72TLMU-A1		
Model name of BC controller			CMB-P108NU-GA1			
Operating conditions	Indoor temperature		DB/WB	21.1°C/- [70 °F/-]		
	Heat source water temperature		°C [°F]	21.1 [70]		
	Heat source water flow rate		m ³ /h G/h gpm	5.76 [1522] [25.4]	5.76 [1522] [25.4]	
	Indoor unit	No. of connected units		Unit	4	
		No. of units in operation			4	
		Model			36/36/36/36	
	Pipe length	Main pipe		m [ft]	5 [16-3/8]	
		Branch pipe			10 [32-3/4]	
		Total pipe length			45 [148]	
	Fan speed		-	Hi		
Refrigerant charge		kg [lbs-oz]	20.3 [45]			
Heat source unit	Current		A	44.3		
	Voltage		V	230		
	Compressor frequency		Hz	60	60	
LEV opening	Indoor unit		Pulse	332/332/332/332		
	BC controller (1/2/3)			110/110/870		
	LEV6			68	68	
	LEV7			41	41	
Pressure switch	High pressure (after O/S)/ Low pressure (before accumulator)		MPa [psi]	2.64/0.80 [383/116]	2.64/0.80 [383/116]	
	BC controller on the liquid side (PS1)/Intermediate part (PS3)		2.61/2.29 [379/332]			
Sectional temperatures	Heat source unit	Discharge (TH4)		77 [171]	77 [171]	
		Heat exchanger outlet		5 [41]	5 [41]	
		Accumulator inlet		4 [39]	4 [39]	
		Accumulator outlet		4 [39]	4 [39]	
		Compressor inlet		4 [39]	4 [39]	
		Compressor shell bottom		40 [104]	40 [104]	
	Indoor unit	LEV inlet		37 [99]		
		Heat exchanger inlet		70 [158]		

Item			2-unit combination			
			PQRY-P168TSLMU-A1			
			PQRY-P96TLMU-A1	PQRY-P72TLMU-A1		
Model name of BC controller			CMB-P108NU-GA1			
Operating conditions	Indoor temperature		DB/WB	21.1°C/- [70 °F/-]		
	Heat source water temperature		°C [°F]	21.1 [70]		
	Heat source water flow rate		m ³ /h G/h gpm	5.76 [1522] [25.4]	5.76 [1522] [25.4]	
	Indoor unit	No. of connected units		Unit	4	
		No. of units in operation			4	
		Model		-	36/36/48/48	
	Pipe length	Main pipe		m [ft]	5 [16-3/8]	
		Branch pipe			10 [32-3/4]	
		Total pipe length			45 [148]	
	Fan speed		-	Hi		
Refrigerant charge		kg [lbs-oz]	23.1 [51]			
Heat source unit	Current		A	44.3		
	Voltage		V	230		
	Compressor frequency		Hz	66	66	
LEV opening	Indoor unit		Pulse	332/332/406/406		
	BC controller (1/2/3)			110/110/870		
	LEV6			84	68	
	LEV7			41	41	
Pressure switch	High pressure (after O/S)/ Low pressure (before accumulator)		MPa [psi]	2.80/0.80 [406/116]	2.80/0.80 [406/116]	
	BC controller on the liquid side (PS1)/Intermediate part (PS3)			2.77/2.45 [402/355]		
Sectional temperatures	Heat source unit	Discharge (TH4)		77 [171]	77 [171]	
		Heat exchanger outlet		5 [41]	5 [41]	
		Accumulator inlet		4 [39]	4 [39]	
		Accumulator outlet		4 [39]	4 [39]	
		Compressor inlet		4 [39]	4 [39]	
		Compressor shell bottom		40 [104]	40 [104]	
	Indoor unit	LEV inlet		37 [99]		
		Heat exchanger inlet		70 [158]		

Item			2-unit combination			
			PQRY-P192TSLMU-A1			
			PQRY-P96TLMU-A1	PQRY-P96TLMU-A1		
Model name of BC controller			CMB-P108NU-GA1			
Operating conditions	Indoor temperature		DB/WB	21.1°C/- [70 °F/-]		
	Heat source water temperature		°C [°F]	21.1 [70]		
	Heat source water flow rate		m ³ /h G/h gpm	5.76 [1522] [25.4]	5.76 [1522] [25.4]	
	Indoor unit	No. of connected units		Unit	4	
		No. of units in operation			4	
		Model			48/48/48/48	
	Pipe length	Main pipe		m [ft]	5 [16-3/8]	
		Branch pipe			10 [32-3/4]	
		Total pipe length			45 [148]	
	Fan speed		-	Hi		
Refrigerant charge		kg [lbs-oz]	24.6 [54]			
Heat source unit	Current		A	51.1		
	Voltage		V	230		
	Compressor frequency		Hz	72	72	
LEV opening	Indoor unit		Pulse	406/406/406/406		
	BC controller (1/2/3)			110/110/980		
	LEV6			84	84	
	LEV7			41	41	
Pressure switch	High pressure (after O/S)/ Low pressure (before accumulator)		MPa [psi]	2.90/0.80 [421/116]	2.90/0.80 [421/116]	
	BC controller on the liquid side (PS1)/Intermediate part (PS3)		2.87/2.55 [416/370]			
Sectional temperatures	Heat source unit	Discharge (TH4)		80 [176]	80 [176]	
		Heat exchanger outlet		5 [41]	5 [41]	
		Accumulator inlet		4 [39]	4 [39]	
		Accumulator outlet		4 [39]	4 [39]	
		Compressor inlet		4 [39]	4 [39]	
		Compressor shell bottom		40 [104]	40 [104]	
	Indoor unit	LEV inlet		37 [99]		
		Heat exchanger inlet		70 [158]		

Item			2-unit combination			
			PQRY-P216TSLMU-A1			
			PQRY-P120TLMU-A1	PQRY-P96TLMU-A1		
Model name of BC controller			CMB-P1013NU-GA1			
Operating conditions	Indoor temperature		DB/WB	21.1°C/- [70 °F/-]		
	Heat source water temperature		°C [°F]	21.1 [70]		
	Heat source water flow rate		m ³ /h G/h gpm	5.76 [1522] [25.4]	5.76 [1522] [25.4]	
	Indoor unit	No. of connected units		Unit	5	
		No. of units in operation			5	
		Model		-	36/36/48/48/48	
	Pipe length	Main pipe		m [ft]	5 [16-3/8]	
		Branch pipe			10 [32-3/4]	
		Total pipe length			65 [213-1/4]	
	Fan speed		-	Hi		
Refrigerant charge		kg [lbs-oz]	26.2 [58]			
Heat source unit	Current		A	55.1		
	Voltage		V	230		
	Compressor frequency		Hz	81	81	
LEV opening	Indoor unit		Pulse	332/332/406/406/406		
	BC controller (1/2/3)			110/110/1050		
	LEV6			122	84	
	LEV7			41	41	
Pressure switch	High pressure (after O/S)/ Low pressure (before accumulator)		MPa [psi]	2.75/0.80 [399/116]	2.75/0.80 [399/116]	
	BC controller on the liquid side (PS1)/Intermediate part (PS3)			2.72/2.40 [395/348]		
Sectional temperatures	Heat source unit	Discharge (TH4)		81 [178]	81 [178]	
		Heat exchanger outlet		5 [41]	5 [41]	
		Accumulator inlet		4 [39]	4 [39]	
		Accumulator outlet		4 [39]	4 [39]	
		Compressor inlet		4 [39]	4 [39]	
		Compressor shell bottom		40 [104]	40 [104]	
	Indoor unit	LEV inlet		35 [95]		
		Heat exchanger inlet		70 [158]		

Item			2-unit combination			
			PQRY-P240TSLMU-A1			
			PQRY-P120TLMU-A1	PQRY-P120TLMU-A1		
Model name of BC controller			CMB-P1013NU-GA1			
Operating conditions	Indoor temperature		DB/WB	21.1°C/- [70 °F/-]		
	Heat source water temperature		°C [°F]	21.1 [70]		
	Heat source water flow rate		m ³ /h G/h gpm	5.76 [1522] [25.4]	5.76 [1522] [25.4]	
	Indoor unit	No. of connected units		Unit	6	
		No. of units in operation			6	
		Model		-	36/36/36/36/48/48	
	Pipe length	Main pipe		m [ft]	5 [16-3/8]	
		Branch pipe			10 [32-3/4]	
		Total pipe length			65 [213-1/4]	
	Fan speed		-	Hi		
Refrigerant charge		kg [lbs-oz]	26.2 [58]			
Heat source unit	Current		A	58.3		
	Voltage		V	230		
	Compressor frequency		Hz	90	90	
LEV opening	Indoor unit		Pulse	332/332/332/332/406/406		
	BC controller (1/2/3)			110/110/1120		
	LEV6			122	122	
	LEV7			41	41	
Pressure switch	High pressure (after O/S)/ Low pressure (before accumulator)		MPa [psi]	2.68/0.80 [389/116]	2.68/0.80 [389/116]	
	BC controller on the liquid side (PS1)/Intermediate part (PS3)		2.64/2.32 [383/336]			
Sectional temperatures	Heat source unit	Discharge (TH4)		81 [178]	81 [178]	
		Heat exchanger outlet		5 [41]	5 [41]	
		Accumulator inlet		4 [39]	4 [39]	
		Accumulator outlet		4 [39]	4 [39]	
		Compressor inlet		4 [39]	4 [39]	
		Compressor shell bottom		40 [104]	40 [104]	
	Indoor unit	LEV inlet		35 [95]		
		Heat exchanger inlet		70 [158]		

Item			2-unit combination			
			PQRY-P288TSLMU-A1			
			PQRY-P144TLMU-A1	PQRY-P144TLMU-A1		
Model name of BC controller			CMB-P1016NU-HA1			
Operating conditions	Indoor temperature		DB/WB	21.1°C/- [70 °F/-]		
	Heat source water temperature		°C [°F]	21.1 [70]		
	Heat source water flow rate		m ³ /h G/h gpm	7.20 [1902] [31.7]	7.20 [1902] [31.7]	
	Indoor unit	No. of connected units		Unit	6	
		No. of units in operation			6	
		Model		-	48/48/48/48/48/48	
	Pipe length	Main pipe		m [ft]	5 [16-3/8]	
		Branch pipe			10 [32-3/4]	
		Total pipe length			65 [213-1/4]	
	Fan speed		-	Hi		
Refrigerant charge		kg [lbs-oz]	22.5 [50]			
Heat source unit	Current		A	58.3		
	Voltage		V	230		
	Compressor frequency		Hz	67	67	
LEV opening	Indoor unit		Pulse	406/406/406/406/406/406		
	BC controller (1/2/3)			110/110/1190		
	LEV6			126	126	
	LEV7			41	41	
Pressure switch	High pressure (after O/S)/ Low pressure (before accumulator)		MPa [psi]	2.54/0.80 [368/116]	2.54/0.80 [368/116]	
	BC controller on the liquid side (PS1)/Intermediate part (PS3)		2.51/2.19 [364/318]			
Sectional temperatures	Heat source unit	Discharge (TH4)		80 [176]	80 [176]	
		Heat exchanger outlet		5 [41]	5 [41]	
		Accumulator inlet		4 [39]	4 [39]	
		Accumulator outlet		4 [39]	4 [39]	
		Compressor inlet		4 [39]	4 [39]	
		Compressor shell bottom		40 [104]	40 [104]	
	Indoor unit	LEV inlet		36 [97]		
		Heat exchanger inlet		70 [158]		

Item			2-unit combination			
			PQRY-P312TSLMU-A1			
			PQRY-P168TLMU-A1	PQRY-P144TLMU-A1		
Model name of BC controller			CMB-P1016NU-HA1			
Operating conditions	Indoor temperature		DB/WB	21.1°C/- [70 °F/-]		
	Heat source water temperature		°C [°F]	21.1 [70]		
	Heat source water flow rate		m ³ /h G/h gpm	7.20 [1902] [31.7]	7.20 [1902] [31.7]	
	Indoor unit	No. of connected units		Unit	6	
		No. of units in operation			6	
		Model		-	54/54/54/54/48/48	
	Pipe length	Main pipe		m [ft]	5 [16-3/8]	
		Branch pipe			10 [32-3/4]	
		Total pipe length			65 [213-1/4]	
	Fan speed		-	Hi		
Refrigerant charge		kg [lbs-oz]	22.5 [50]			
Heat source unit	Current		A	66.9		
	Voltage		V	230		
	Compressor frequency		Hz	73	73	
LEV opening	Indoor unit		Pulse	414/414/414/414/406/406		
	BC controller (1/2/3)			110/110/1190		
	LEV6			145	145	
	LEV7			41	41	
Pressure switch	High pressure (after O/S)/ Low pressure (before accumulator)		MPa [psi]	2.58/0.80 [374/116]	2.58/0.80 [374/116]	
	BC controller on the liquid side (PS1)/Intermediate part (PS3)		2.55/2.23 [370/323]			
Sectional temperatures	Heat source unit	Discharge (TH4)		80 [176]	80 [176]	
		Heat exchanger outlet		5 [41]	5 [41]	
		Accumulator inlet		4 [39]	4 [39]	
		Accumulator outlet		4 [39]	4 [39]	
		Compressor inlet		4 [39]	4 [39]	
		Compressor shell bottom		40 [104]	40 [104]	
	Indoor unit	LEV inlet		36 [97]		
		Heat exchanger inlet		70 [158]		

Item			2-unit combination			
			PQRY-P336TSLMU-A1			
			PQRY-P168TLMU-A1	PQRY-P168TLMU-A1		
Model name of BC controller			CMB-P1016NU-HA1			
Operating conditions	Indoor temperature		DB/WB	21.1°C/- [70 °F/-]		
	Heat source water temperature		°C [°F]	21.1 [70]		
	Heat source water flow rate		m ³ /h G/h gpm	7.20 [1902] [31.7]	7.20 [1902] [31.7]	
	Indoor unit	No. of connected units		Unit	7	
		No. of units in operation			7	
		Model		-	48/48/48/48/48/48/48	
	Pipe length	Main pipe		m [ft]	5 [16-3/8]	
		Branch pipe			10 [32-3/4]	
		Total pipe length			65 [213-1/4]	
	Fan speed		-	Hi		
Refrigerant charge		kg [lbs-oz]	23.5 [52]			
Heat source unit	Current		A	76.7		
	Voltage		V	230		
	Compressor frequency		Hz	78	78	
LEV opening	Indoor unit		Pulse	406/406/406/406/406/406/406		
	BC controller (1/2/3)			110/110/1190		
	LEV6			164	164	
	LEV7			41	41	
Pressure switch	High pressure (after O/S)/ Low pressure (before accumulator)		MPa [psi]	2.62/0.80 [380/116]	2.62/0.80 [380/116]	
	BC controller on the liquid side (PS1)/Intermediate part (PS3)			2.59/2.27 [376/329]		
Sectional temperatures	Heat source unit	Discharge (TH4)		81 [178]	81 [178]	
		Heat exchanger outlet		5 [41]	5 [41]	
		Accumulator inlet		4 [39]	4 [39]	
		Accumulator outlet		4 [39]	4 [39]	
		Compressor inlet		4 [39]	4 [39]	
		Compressor shell bottom		40 [104]	40 [104]	
	Indoor unit	LEV inlet		37 [99]		
		Heat exchanger inlet		70 [158]		

IX Troubleshooting

[1] Error Code Lists	261
[2] Responding to Error Display on the Remote Controller	265
[3] Investigation of Transmission Wave Shape/Noise.....	347
[4] Troubleshooting Principal Parts	350
[5] Refrigerant Leak	402
[6] Compressor Replacement Instructions.....	406
[7] Water-cooled heat exchanger Replacement Instructions	409
[8] Servicing the BC controller	421
[9] Troubleshooting Using the Heat source Unit LED Error Display	424



[1] Error Code Lists

Error Code	Preliminary error code	Error (preliminary) detail code	Error code definition	Searched unit					Notes
				Heat source unit	Indoor unit	BC controller	LOSSNAY	Remote controller	
0403	4300	01	Serial communication error/Panel communication error	O	O				
0404	-	-	Indoor unit EEPROM abnormality		O				
1102	1202	-	Discharge temperature fault	O					
1301	-	-	Low pressure fault	O					
1302	1402	-	High pressure fault	O					
1500	1600	-	Refrigerant overcharge	O					
-	1605	-	Preliminary suction pressure fault	O					
2000	2100	-	Pump interlock error	O					
2134	2234	-	Abnormal water temperature	O					
2135	2235	-	Water heat exchanger freeze up	O					
2500	-	-	Drain sensor submergence		O				
2502	-	-	Drain pump fault		O	O			
2503	-	-	Drain sensor (Thd) fault		O		O		
2600	-	-	Water leakage				O		
2601	-	-	Water supply cutoff				O		
2602	-	-	Function setting fault				O		
4102	4152	-	Open phase	O					
4106	-	-	Transmission power supply fault	O					
4115	-	-	Power supply signal sync error	O					
4116	-	-	RPM error/Motor error		O		O		
4109	-	-	Fan operation status detection error		O				
4220	4320	[0]	Backup operation	O					
		[108]	Abnormal bus voltage drop (S/W detection)	O	O				
		[109]	Abnormal bus voltage rise (S/W detection)	O	O				
		[110]	Bus voltage error (H/W detection)	O					
		[111]	Logic error	O					
		[112]	Logic error	O					
		[123]	Voltage boost control error	O					
		[124]	BUS voltage circuit fault	O					
	[131]	Low bus voltage at startup	O						
4121	4171	-	Function setting error	O					
4124	-	-	Electric system not operate due to damper abnormality		O				
4230	4330	[125]	Heatsink overheat protection	O					
		[126]	DCL temperature fault	O					
4240	4340	-	Overload protection	O					

Error Code	Preliminary error code	Error (preliminary) detail code	Error code definition	Searched unit					Notes		
				Heat source unit	Indoor unit	BC controller	LOSSNAY	Remote controller			
4250	4350	[0]	Backup operation	O							
		[101]	IPM error	O							
		[103]	DCCT overcurrent (H/W detection)	O							
		[104]	Short-circuited IPM/Ground fault	O							
		[105]	Overcurrent error due to short-circuited motor	O							
		[106]	Instantaneous overcurrent (S/W detection)	O							
		[107]	Overcurrent (effective value)(S/W detection)	O							
		[121]	DCL Overcurrent (H/W detection)	O							
		[122]	DCL Overcurrent (S/W detection)	O							
[128]	DCL Overcurrent (H/W detection)	O									
4260	-	-	Heatsink overheat protection at startup	O							
5101	1202	-	Temperature sensor fault	Return air temperature (TH21)		O					
				OA processing unit inlet temperature (TH4)				O			
5102	1217	-	Temperature sensor fault	Indoor unit pipe temperature (TH22)		O					
				OA processing unit pipe temperature (TH2)				O			
				HIC bypass circuit outlet temperature (TH2)	O						
5103	1205	00	Temperature sensor fault	Indoor unit gas-side pipe temperature (TH23)		O					
				OA processing unit gas-side pipe temperature (TH3)				O			
				Pipe temperature at heat exchanger outlet (TH3)	O						
5104	1202	-	Temperature sensor fault	OA processing unit intake air temperature (TH1)				O			
				Outside temperature (TH24)		O					Detectable only by the All-Fresh type indoor units
				Heat source unit discharge temperature (TH4)	O						
5105	1204	-	Temperature sensor fault	Accumulator inlet temperature (TH5)	O						
5106	1216	-	Temperature sensor fault	HIC circuit outlet temperature (TH6)	O						
5107	1221	-	Temperature sensor fault	Water inlet pipe (TH7)	O						
5108	1218	-	Temperature sensor fault	Water outlet pipe (TH8)	O						
5112	1215	-	Temperature sensor fault	Component cooler heat exchanger outlet (THINV)	O						

Error Code	Preliminary error code	Error (preliminary) detail code	Error code definition		Searched unit					Notes
					Heat source unit	Indoor unit	BC controller	LOSSNAY	Remote controller	
5110	1214	01	Temperature sensor fault	Heatsink temperature (THHS)	O					
5111	-	-	Temperature sensor fault (BC controller)	Liquid inlet temperature (TH11)			O			
5112	-	-		Bypass outlet temperature (TH12)			O			
5115	-	-		LEV3 outlet temperature (TH15)			O			
5116	-	-		LEV3 inlet temperature (TH16)			O			
5201	-	-	High-pressure sensor fault (63HS1)		O					
5201	1402	-	High-pressure sensor fault (Heat source unit HPS/BC controller PS1)		O		O			
5203	-	-	Intermediate pressure sensor fault (BC controller PS3)				O			
5301	4300	[0]	Backup operation		O					
		[115]	ACCT sensor fault		O	O				
		[116]	DCCT sensor fault		O					
		[117]	ACCT sensor circuit fault		O	O				
		[118]	DCCT sensor circuit fault		O					
		[119]	Open-circuited IPM/Loose ACCT connector		O	O				
		[120]	Faulty ACCT wiring		O	O				
		[127]	DCL sensor circuit fault		O					
5701	-	-	Loose float switch connector			O				
6201	-	-	Remote controller board fault (nonvolatile memory error)						O	
6202	-	-	Remote controller board fault (clock IC error)						O	
6600	-	-	Address overlaps		O	O	O	O	O	
6601	-	-	Polarity setting error		O					
6602	-	-	Transmission processor hardware error		O	O	O	O	O	
6603	-	-	Transmission line bus busy error		O	O	O	O	O	
6606	-	-	Communication error between device and transmission processors		O	O	O	O	O	
6607	-	-	No ACK error		O	O	O	O	O	
6608	-	-	No response error		O	O	O	O	O	
6831	-	-	MA controller signal reception error (No signal reception)			O			O	
6832	-	-	MA remote controller signal transmission error (Synchronization error)			O			O	
6833	-	-	MA remote controller signal transmission error (H/W error)			O			O	
6834	-	-	MA controller signal reception error (Start bit detection error)			O			O	
7100	-	-	Total capacity error		O					
7101	-	-	Capacity code setting error		O	O		O		
7102	-	-	Wrong number of connected units		O		O			
7105	-	-	Address setting error		O					
7106	-	-	Attribute setting error					O		
7107	-	-	Port setting error				O			

[IX Troubleshooting]

Error Code	Preliminary error code	Error (preliminary) detail code	Error code definition	Searched unit					Notes
				Heat source unit	Indoor unit	BC controller	LOSSNAY	Remote controller	
7110	-	-	Connection information signal transmission/reception error	O					
7111	-	-	Remote controller sensor fault		O		O		
7113	-	-	Function setting error	O					
7117	-	-	Model setting error	O					
7130	-	-	Incompatible unit combination	O					

INV board	model	Overload protection I _{max} (Arms)	Current effective value error (Arms)	Current peak value error (A _{peak})	Temperature protection TOL (°C)
INV24	PQHY-P72TLMU-A1	35	42	71	95
	PQHY-P96TLMU-A1	35	42	71	95
	PQHY-P120TLMU-A1	35	42	71	95
INV25	PQHY-P144TLMU-A1	53	64	106	80
	PQHY-P168TLMU-A1	53	64	106	80
	PQHY-P192TLMU-A1	53	64	106	80
INV29C	PQHY-P216TLMU-A1	42	50	82	90
	PQHY-P240TLMU-A1	42	50	82	90
INV20Y	PQHY-P72YLMU-A1	19	23	38	100
	PQHY-P96YLMU-A1	19	23	38	100
	PQHY-P120YLMU-A1	19	23	38	100
	PQHY-P144YLMU-A1	27	33	56	100
	PQHY-P168YLMU-A1	27	33	56	100
	PQHY-P192YLMU-A1	27	33	56	100
	PQHY-P216YLMU-A1	27	35	94	100
	PQHY-P240YLMU-A1	27	35	94	100

INV board	model	Overload protection I _{max} (Arms)	Current effective value error (Arms)	Current peak value error (A _{peak})	Temperature protection TOL (°C)
INV24	PQRY-P72TLMU-A1	35	42	71	95
	PQRY-P96TLMU-A1	35	42	71	95
	PQRY-P120TLMU-A1	35	42	71	95
INV25	PQRY-P144TLMU-A1	53	64	106	80
	PQRY-P168TLMU-A1	53	64	106	80
	PQRY-P192TLMU-A1	53	64	106	80
INV29C	PQRY-P216TLMU-A1	42	50	82	90
	PQRY-P240TLMU-A1	42	50	82	90
INV20Y	PQRY-P72YLMU-A1	19	23	38	95
	PQRY-P96YLMU-A1	19	23	38	95
	PQRY-P120YLMU-A1	19	23	38	95
	PQRY-P144YLMU-A1	27	33	56	95
	PQRY-P168YLMU-A1	27	33	56	95
	PQRY-P192YLMU-A1	27	33	56	95
	PQRY-P216YLMU-A1	27	35	94	95
	PQRY-P240YLMU-A1	27	35	94	95

[2] Responding to Error Display on the Remote Controller

1. Error Code

0403

Serial communication error

2. Error definition and error detection method

Serial communication error between the control board and the INV board on the compressor.

Detail code 01: Between the control board and the INV board

3. Cause, check method and remedy

(1) Faulty wiring

Check the following wiring connections.

- 1) Between Control board and INV board

Control board	INV board
CN61	CN2
CN4	CN4(or CN43)
CN2	CN5V

(2) INV board failure and Control board failure

Replace the INV board or the Fan board when the power turns on automatically, even if the power source is reset.

Note

Refer to section -6- "Inverter" under part [4] Troubleshooting Principal Parts for error codes related to the inverter.

1. Error Code

0403

Panel communication error (Indoor unit)

2. Error definition and error detection method

This error is detected when indoor units cannot successfully receive the signals from the Auto filter cleaning unit for one minute.

3. Cause, check method and remedy

Cause	Check method and remedy
(1) Incorrect switch setting on the indoor unit circuit board	Check SW3-3 on the indoor unit circuit board Set SW3-3 to ON only when connecting an auto filter cleaning unit.
(2) Power wire that connects the circuit board on the indoor unit and the circuit board on the cleaning unit is loose.	Check the LED1 (cleaning unit circuit board (microcomputer power)). Lit: Power is supplied properly. Unlit: Check for loose or disconnected power wire between the indoor unit circuit board (CNAC) and the cleaning unit circuit board (CN3A).
(3) Communication wire that connects the circuit board on the indoor unit and the circuit board on the cleaning unit is loose.	Check the LED4 (cleaning unit circuit board (communication)). Blinking: Normal communication Unlit: Check for loose or disconnected communication wire between the indoor unit circuit board (CN3G) and the cleaning unit circuit board (CN3G).
(4) Panel transceiver circuit fault (cleaning unit)	If the LED blinks at irregular intervals (normally blinks at 0.5-second intervals), electrical interference is suspected. Check the items above, turn the power off, and turn the power back on. If the error persists, replace either the cleaning unit circuit board or the indoor unit circuit board.
(5) Panel transceiver circuit fault (indoor unit)	
(6) Electrical interference on the cleaning unit's communication cable	

1. Error Code

0404

A control communication reception error

2. Error definition and error detection method

Indoor controller board

Abnormal if data cannot be read normally from the nonvolatile memory of the indoor controller board.

3. Cause, check method and remedy

Cause	Check method and remedy
Defective indoor controller board	Replace indoor controller board.

1. Error Code

1102

Discharge temperature fault

2. Error definition and error detection method

- 1) If the discharge temperature of 120 °C [248°F] or more is detected during the above operation (the first detection), the heat source unit stops once, turns to anti-restart mode for 3 minutes, and restarts after 3 minutes automatically.
- 2) If the discharge temperature of 120° C [248°F] or more is detected again (the second detection) within 30 minutes after the second stop of the heat source unit described above, the mode will be changed to 3 - minute restart mode, then the heat source unit will restart in 3 minutes.
- 3) If the discharge temperature of 120°C [248°F] or more is detected (the third detection) within 30 minutes after the stop of the heat source unit described above (regardless of the first or the second stop), the heat source unit will make an error stop, and the error code "1102" will be displayed.
- 4) If the discharge temperature of 120°C [248°F] or more is detected more than 30 minutes after the previous stop of the heat source unit, the detection is regarded as the first detection, and the operation described in step 1 above will start.
- 5) For 30 minutes after the stop (the first stop or the second stop) of the heat source unit, preliminary errors will be displayed on the LED display.

3. Cause, check method and remedy

Cause	Check method and remedy	
(1) Gas leak, gas shortage	Refer to the page on refrigerant amount evaluation.	
(2) Overload operation	Check operating conditions and operation status of indoor/ heat source units.	
(3) LEV failure on the indoor unit (4) BC controller LEV malfunction Cooling only : LEV3 Cooling main : LEV1,2,3 Heating only or heating main : LEV3	Perform a heating operation and check the operation. Cooling: LEV on the indoor unit BC controller LEV1,2,3 Heat source unit LEV1,LEV7 BC controller SVM1,2 BC controller SVA,C Heating: LEV on the indoor unit Heat source unit LEV6,LEV7,SV4a - 4d,7a,7b BC controller LEV3 BC controller SVB Refer to the page on troubleshooting LEV.	
(5) BC controller SVM1 and 2 malfunction -> Cooling only or defrost		
(6) BC controller SVA malfunction -> Cooling only or cooling main		
(7) BC controller SVB malfunction -> Heating only or heating main		
(8) Solenoid valve SV malfunction 4a-4d,7a,7b :heating only, heating main		
(9) Heat source unit LEV1,LEV6, LEV7 actuation failure		
(10) Port address setting error.		Confirm the port address of the indoor unit.
(11) Closed ball valve		Confirm that the ball valve is fully open.
(12) Insufficient heat source water flow, heat source water supply cutoff, dirty or clogged water heat exchanger → Heating		Check the water heat exchanger for clogging. Check the heat source water circulation pump.
(13) Gas leak between low and high pressures (4-way valve failure, Compressor failure, Solenoid valve (SV1a) failure)	Perform a cooling or heating operation and check the operation.	
(14) Thermistor failure (TH4)	Check the thermistor resistor.	
(15) Input circuit failure on the controller board thermistor	Check the inlet air temperature on the LED monitor.	

1. Error Code

1301

Low pressure fault

2. Error definition and error detection method

When starting the compressor from Stop Mode for the first time if low pressure reads 0.098MPa [14psi] immediately before start-up, the operation immediately stops.

3. Cause, check method and remedy

Cause	Check method and remedy
(1) Inner pressure drop due to a leakage.	Refer to the section on troubleshooting the low pressure sensor.
(2) Low pressure sensor failure	
(3) Short-circuited pressure sensor cable due to torn outer rubber	
(4) A pin on the male connector is missing.	
(5) Disconnected wire	
(6) Failure of the low pressure input circuit on the controller board	

1. Error Code

1302

High pressure fault 1 (Heat source unit)

2. Error definition and error detection method

- 1) If the pressure of 3.78MPa [548psi] or higher is detected by the pressure sensor during operation (the first detection), the heat source stops once, turns to antirestart mode for 3 minutes, and restarts after 3 minutes automatically.
- 2) If the pressure of 3.78MPa [548psi] or higher is detected by the pressure sensor again (the second detection) within 30 minutes after the first stop of the heat source unit, the heat source unit stops once, turns to anti-restart mode for 3 minutes, and restarts after 3 minutes automatically.
- 3) If the pressure of 3.87MPa [561psi] or higher is detected by the pressure sensor (the third detection) within 30 minutes of the second stop of the heat source unit, the heat source unit will make an error stop, and the error code "1302" will be displayed.
- 4) If the pressure of 3.78MPa [548psi] or higher is detected more than 30 minutes after the stop of the heat source unit, the detection is regarded as the first detection, and the operation described in step 1 above will start.
- 5) For 30 minutes after the stop of the heat source unit, preliminary errors will be displayed on the LED display.
- 6) The heat source unit makes an error stop immediately when not only the pressure sensor but also the pressure switch detects $4.15^{+0,-0.15}$ MPa [$601^{+0,-22}$ psi]
- 7) Open phase due to unstable power supply voltage may cause the pressure switch to malfunction or cause the units to come to an abnormal stop.

3. Cause, check method and remedy

Cause	Check method and remedy
(1) Indoor unit LEV actuation failure → Heating	Perform a heating operation and check the operation. Cooling: LEV on the indoor unit Heat source unit LEV7 BC controller LEV1,2,3 BC controller SVM1,1b,2,2b BC controller SVA Heating: LEV on the indoor unit Heat source unit LEV7 BC controller LEV3 BC controller SVM2,2b BC controller SVB Refer to the page on troubleshooting for LEV and solenoid valve.
(2) BC controller LEV malfunction Heating only or heating main : Indoor LEV 3	
(3) BC controller SVM1 and 2 malfunction ->Cooling only	
(4) BC controller SVA and SVC malfunction ->Cooling only or cooling main	
(5) BC controller SVB malfunction ->Heating only or heating main	
(6) Heat source unit LEV7 actuation failure →Cooling	
(7) Port address setting error.	Confirm the port address of the indoor unit.
(8) Refrigerant service valve actuation failure	Confirm that the refrigerant service valve is fully
(9) Short cycle on the indoor unit side	Check the indoor units for problems and correct them, if any.
(10) Clogged filter on the indoor unit	
(11) Reduced air flow due to dirty fan on the indoor unit fan	
(12) Dirty heat exchanger of the indoor unit	
(13) Insufficient heat source water flow	Check the water heat exchanger for clogging. Check the heat source water circulation pump.
(14) Heat source water supply cutoff	
(15) Dirty or clogged water heat exchanger Items (13) through (15) above reduce the condensing capability of the unit, resulting in high-pressure rise during heating operation.	
(16) Solenoid valve (SV1a) malfunction The by-pass valve (SV1a) can not control rise in high pressure.	Refer to the section on troubleshooting the solenoid valve.
(17) Thermistor failure (TH3, TH7)	Check the thermistor resistor.
(18) Pressure sensor failure	Refer to the page on the troubleshooting of the high pressure sensor.
(19) Failure of the thermistor input circuit and pressure sensor input circuit on the controller board	Check the sensor temperature/pressure on the LED monitor.
(20) Thermistor mounting problem (TH3, TH7)	Check the sensor temperature/pressure on the LED monitor.
(21) Disconnected male connector on the pressure switch (63H1) or disconnected wire	
(22) Voltage drop caused by unstable power supply voltage	Check the input voltage at the power supply terminal TB1.

Cause	Check method and remedy
(23) SW4(810) setting error	When using the water flow rate control valve, check the type of valve and setting the switch in the following. *SW4(810) is OFF: 0 V (Fully open), 10 V (Fully closed) *SW4(810) is ON: 0 V (Fully closed), 10 V (Fully open)
(24) Broken the water flow rate control valve	Replace the water flow rate control valve

1. Error Code

1302

High pressure fault 2 (Heat source unit)

2. Error definition and error detection method

If the pressure of 0.098MPa [14psi] or lower is registered on the pressure sensor immediately before start-up, it will trigger an abnormal stop, and error code "1302" will be displayed.

3. Cause, check method and remedy

Cause		Check method and remedy
(1)	Inner pressure drop due to a leakage.	Refer to the page on the troubleshooting of the high pressure sensor.
(2)	Pressure sensor failure	
(3)	Shorted-circuited pressure sensor cable due to torn outer rubber	
(4)	A pin on the male connector on the pressure sensor is missing or contact failure	
(5)	Disconnected pressure sensor cable	
(6)	Failure of the pressure sensor input circuit on the controller board	

1. Error Code

1500

Refrigerant overcharge

2. Error definition and error detection method

An error can be detected by the discharge temperature superheat.

- 1) If the formula " $TdSH \leq 10^{\circ}C [18^{\circ}F]$ " is satisfied during operation (first detection), the heat source unit stops, goes into the 3-minute restart mode, and starts up in three minutes.
- 2) If the formula " $TdSH \leq 10^{\circ}C [18^{\circ}F]$ " is satisfied again within 30 minutes of the first stoppage of the heat source unit (second detection), the unit comes to an abnormal stop, and the error code "1500" appears.
- 3) If the formula " $TdSH \leq 10^{\circ}C [18^{\circ}F]$ " is satisfied 30 minutes or more after the first stoppage of the heat source unit, the same sequence as Item "1" above (first detection) is followed.
- 4) For 30 minutes after the stop of the heat source unit, preliminary errors will be displayed on the LED display.

3. Cause, check method and remedy

Cause		Check method and remedy
(1)	Overcharged refrigerant	Refer to the page on refrigerant amount evaluation.
(2)	Thermistor input circuit failure on the control board	Check the temperature and pressure readings on the sensor that are displayed on the LED monitor.
(3)	Faulty mounting of thermistor (TH4)	Check the temperature and pressure readings on the thermistor that are displayed on the LED monitor.
(4)	Heat source unit LEV6 and LEV7 actuation failure →Heating	Refer to the section on troubleshooting the LEV.

1. Error Code

2000

Pump interlock error

2. Error definition and error detection method

- 1) This error is detected by the pump interlock circuit (TB8 3-4).
- 2) If it is detected that the pump interlock circuit (TB8 3-4) is open (first detection) during operation or immediately before startup, the heat source unit stops and goes into the 10-minute restart delay mode.
- 3) If the pump interlock circuit (TB8 3-4) has remained open for continuous 10 minutes (second detection) since the first stoppage of the heat source unit, the unit will make an abnormal stop, and the error code "2000" appears on the LED.
- 4) For the 10 minutes from the time the heat source stopped is considered a preliminary error, and it is indicated on the LED.
- 5) This error is indicated on the LED only when Dip switch SW4 No.919(SW6-10: ON) on the control board of the heat source unit is set to OFF.

3. Cause, check method and remedy

Cause	Check method and remedy
(1) Heat source water circulation pump fault	Operate the pump, and check for proper operation.
(2) Broken wire	Check the field wiring for proper installation and conduction.
(3) Loose connectors or contact failure	Check the control board connector CNOUT,CN63PW,CNAC2,CN510 and I/O board connector CNOUT2,CNPW,CNAC4,TB9 for proper connection.
(4) Interlock signal input circuit fault on the I/O board	Replace the I/O board. If the problem persists, replace the control board.
(5) Interlock signal input circuit fault on the control board	
(6) SW4(917) setting error	When using pump operation ON signal, set SW4(917) to ON.
(7) SW4(901) and SW4(917) setting error	When using the water flow rate control valve, check the setting the switches in the following combinations. *Set SW4(901) to OFF and SW4(917) to ON *Set SW4(901) to ON and SW4(917) to OFF
(8) SW4(810) setting error	When using the water flow rate control valve, check the type of valve and setting the switch in the following. *SW4(810) is OFF: 0 V (Fully open), 10 V (Fully closed) *SW4(810) is ON: 0 V (Fully closed), 10 V (Fully open)
(9) Broken the water flow rate control valve	Replace the water flow rate control valve
(10) Broken the water flow switch	Replace the water flow switch

1. Error Code

2134

Abnormal water temperature

2. Error definition and error detection method

- 1) If a water inlet pipe temperature (TH7) of 5°C[41°F] or below OR 50°C[122°F] or above is detected (first detection) during operation, the heat source unit stops, goes into the 3-minute restart delay mode, and automatically restarts after three minutes.
- 2) If a water inlet pipe temperature (TH7) of 5°C[41°F] or below OR 50°C[122°F] or above is detected again (second detection) within 30 minutes of the first stoppage of the heat source unit, the unit will make an abnormal stop, and the error code "2134" appears on the LED.
- 3) If a water inlet pipe temperature (TH7) of 5°C[41°F] or below OR 50°C[122°F] or above is detected after 30 minutes of the first stoppage of the heat source unit, this is considered as the first detection, and the sequence as described in section 1) above is followed.
- 4) The period of 30 minutes after a stoppage of the heat source unit is considered a preliminary error, and a preliminary error code appears on the LED display.

3. Cause, check method and remedy

Cause	Check method and remedy
(1) Heat source water circulation pump fault	Operate the pump, and check for proper operation.
(2) Cooling tower or heater problem	Check the cooling tower and heater, and correct any problems found.
(3) Thermistor fault (TH7)	Check thermistor resistance.
(4) Thermistor signal input circuit fault on the control board	Check the sensor reading on the LED.
(5) Improper installation of thermistor (TH7)	Check the sensor reading on the LED.

1. Error Code

2135

Water heat exchanger freeze up

2. Error definition and error detection method

- 1) If either of the following conditions is detected (first detection) during operation, the heat source unit stops, goes into the 3-minute restart delay mode, and automatically restarts after three minutes.
 - *Water outlet pipe temperature (TH8) of 4°C[39°F] or below is detected.
 - *All of the following conditions are continuously met for one minute during Heating-only or Heating-main operation: Compressor frequency < Minimum frequency + 20 AND Evaporation temperature (Te) < -2°C[28°F] AND Accumulator inlet pipe temperature (TH5) ≤ 3°C[37°F].
- 2) If the conditions above (1) are met again within 60 minutes of the first stoppage of the heat source unit (second detection), the unit will make an abnormal stop, and the error code "2135" will appear on the LED.
- 3) If the conditions above (1) are met again after 60 minutes of the first stoppage of the heat source unit, it is considered the first detection, and the sequence as described in section 1) above is followed.
- 4) For the 60 minutes from the time the heat source stopped is considered a preliminary error, and it is indicated on the LED.

3. Cause, check method and remedy

Cause	Check method and remedy
(1) Heat source water circulation pump fault	Operate the pump, and check for proper operation.
(2) Heater problem	Check the heater, and correct any problems found.
(3) Poorly maintained field-installed water pipes	Identify and remove the cause of water flow reduction, such as a clogged strainer or cavitation.
(4) Dirty or clogged water heat exchanger	Check the pressure difference between the unit's inlet and outlet.
(5) Thermistor fault (TH5, TH8)	Check thermistor resistance.
(6) Thermistor signal input circuit fault on the control board	Check the sensor reading on the LED.
(7) Improper installation of thermistor (TH5, TH8)	Check the sensor reading on the LED.
(8) SW4(810) setting error	When using the water flow rate control valve, check the type of valve and setting the switch in the following. *SW4(810) is OFF: 0 V (Fully open), 10 V (Fully closed) *SW4(810) is ON: 0 V (Fully closed), 10 V (Fully open)
(9) Broken the water flow rate control valve	Replace the water flow rate control valve

1. Error Code

2500

Drain sensor submergence (Models with a drain sensor)

2. Error definition and error detection method

- 1) If an immersion of the drain sensor in the water is detected while the unit is in any mode other than the Cool/Dry mode and when the drain pump goes from OFF to ON, this condition is considered preliminary water leakage. While this error is being detected, humidifier output cannot be turned on. (Applicable to the units manufactured in or after October 1996)
- 2) If the immersion of the sensor in the water is detected four consecutive times at an hour interval, this is considered water leakage, and "2500" appears on the monitor.
- 3) Detection of water leakage is also performed while the unit is stopped.
- 4) Preliminary water leakage is cancelled when the following conditions are met:
 - *One hour after the preliminary water leakage was detected, it is not detected that the drain pump goes from OFF to ON.
 - *The operation mode is changed to Cool/Dry.
 - *Liquid pipe temperature - inlet temperature $\leq -10^{\circ}\text{C}$ [-18°F]

3. Cause, check method and remedy

Cause	Check method and remedy
(1) Drain water drainage problem •Clogged drain pump •Clogged drain piping •Backflow of drain water from other units	Check for proper drainage.
(2) Adhesion of water drops to the drain sensor •Trickling of water along the lead wire •Rippling of drain water caused by filter clogging	1) Check for proper lead wire installation. 2) Check for clogged filter.
(3) Failure of the relay circuit for the solenoid valve	Replace the relay.
(4) Indoor unit control board failure •Drain sensor circuit failure	If the above item checks out OK, replace the indoor unit control board.

1. Error Code

2500

Drain sensor submergence (Models with a float switch)

2. Error definition and error detection method

- 1) If an immersion of the float switch in the water is detected while the unit is in any mode other than the Cool/Dry mode and when the drain pump goes from OFF to ON, this condition is considered preliminary water leakage. While this error is being detected, humidifier output cannot be turned on.
- 2) If the drain pump turns on within one hour after preliminary water leakage is detected and the above-mentioned condition is detected two consecutive times, water leakage error water leakage is detected, and "2500" appears on the monitor.
- 3) Detection of water leakage is also performed while the unit is stopped.
- 4) Preliminary water leakage is cancelled when the following conditions are met:
 - *One hour after the preliminary water leakage was detected, it is not detected that the drain pump goes from OFF to ON.
 - *The operation mode is changed to Cool/Dry.
 - *Liquid pipe temperature - inlet temperature $\leq - 10^{\circ}\text{C}[-18^{\circ}\text{F}]$

3. Cause, check method and remedy

Cause	Check method and remedy
(1) Drain water drainage problem •Clogged drain pump •Clogged drain piping •Backflow of drain water from other units	Check for proper drainage.
(2) Stuck float switch Check for slime in the moving parts of the float switch.	Check for normal operation of the float switch.
(3) Float switch failure	Check the resistance with the float switch turned on and turned off.

<Reference>

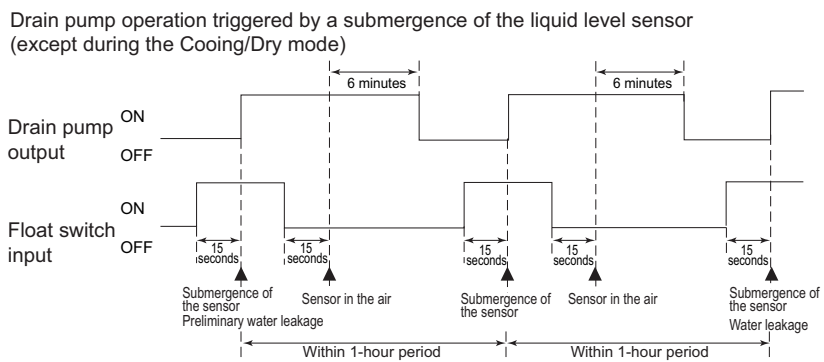

1. Error Code

2502

Drain pump fault (Models with a drain sensor)

2. Error definition and error detection method

- 1) Make the drain sensor thermistor self-heat. If the temperature rise is small, it is interpreted that the sensor is immersed in water. This condition is considered to be a preliminary error, and the unit goes into the 3-minute restart delay mode.
- 2) If another episode of the above condition is detected during the preliminary error, this is considered a drain pump error, and "2502" appears on the monitor.
- 3) This error is always detected while the drain pump is in operation.
- 4) The following criteria are met when the criteria for the forced stoppage of heat source unit (system stoppage) are met.
 - *"Liquid pipe temperature - inlet temperature \leq - 10 °C [-18°F] " has been detected for 30 minutes.
 - *The immersion of drain sensor is detected 10 consecutive times.
 - *The conditions that are listed under items 1) through 3) above are always met before the criteria for the forced stoppage of the heat source unit.
- 5) The indoor unit that detected the conditions that are listed in item 4) above brings the heat source unit in the same refrigerant circuit to an error stop (compressor operation prohibited), and the heat source unit brings all the indoor units in the same refrigerant circuit that are in any mode other than Fan or Stop to an error stop. "2502" appears on the monitor of the units that came to an error stop.
- 6) Forced stoppage of the heat source unit
 Detection timing: The error is detected whether the unit is in operation or stopped.
- 7) Ending criteria for the forced stoppage of heat source unit
 Power reset the indoor unit that was identified as the error source and the heat source unit that is connected to the same refrigerant circuit.
 Forced stoppage of the heat source unit cannot be cancelled by stopping the unit via the remote controller.
 (Note) Items 1) - 3) and 4) - 7) are detected independently from each other.

Note

The address and attribute that appear on the remote controller are those of the indoor unit (or OA processing unit) that caused the error.

3. Cause, check method and remedy

Cause	Check method and remedy
(1) Drain pump failure	Check for proper functioning of the drain pump.
(2) Drain water drainage problem <ul style="list-style-type: none"> •Clogged drain pump •Clogged drain piping 	Check for proper drainage.
(3) Adhesion of water drops to the drain sensor <ul style="list-style-type: none"> •Trickling of water along the lead wire •Rippling of drain water caused by filter clogging 	1) Check for proper lead wire installation. 2) Check for clogged filter.
(4) Indoor unit control board failure <ul style="list-style-type: none"> •Drain pump drive circuit failure •Drain heater output circuit failure 	If the above item checks out OK, replace the indoor unit control board.
(5) Items (1) through (4) above and an indoor unit electronic valve closure failure (leaky valve) occurred simultaneously.	Check the solenoid valves on the indoor unit for leaks.

1. Error Code

2502

Drain pump fault (Models with a float switch)

2. Error definition and error detection method

- 1) The immersion of sensor tip in water is detected by the ON/OFF signal from the float switch.
 - *Submergence of the sensor
When it is detected that the float switch has been ON for 15 seconds, it is interpreted that the sensor tip is immersed in water.
 - *Sensor in the air
When it is detected that the float switch has been OFF for 15 seconds, it is interpreted that the sensor tip is not immersed in water.
- 2) If it is detected that the float switch has been ON for 3 minutes after the immersion of the sensor tip was detected, this is considered a drain pump failure, and "2502" appears on the monitor.
 - *The total time it takes for this error to be detected is 3 minutes and 15 seconds, including the time it takes for the first immersion of the sensor tip to be detected.
- 3) Detection of drain pump failure is performed while the unit is stopped.
- 4) The following criteria are met when the criteria for the forced stoppage of heat source unit (system stoppage) are met.
 - *"Liquid pipe temperature - inlet temperature $\leq -10^{\circ}\text{C}$ [-18°F] " has been detected for 30 minutes.
 - *It is detected by the float switch that the sensor tip has been immersed in water for 15 minutes or more.
 - *The conditions that are listed under items 1) through 3) above are always met before the criteria for the forced stoppage of the heat source unit.
- 5) The indoor unit that detected the conditions that are listed in item 4) above brings the heat source unit in the same refrigerant circuit to an error stop (compressor operation prohibited), and the heat source unit brings all the indoor units in the same refrigerant circuit that are in any mode other than Fan or Stop to an error stop.
- 6) Forced stoppage of the heat source unit
Detection timing: The error is detected whether the unit is in operation or stopped.
This error is detected whether the unit is in operation or stopped.
- 7) Ending criteria for the forced stoppage of heat source unit
Power reset the indoor unit that was identified as the error source and the heat source unit that is connected to the same refrigerant circuit.
Forced stoppage of the heat source unit cannot be cancelled by stopping the unit via the remote controller.
(Note) Items 1) - 3) and 4) - 7) are detected independently from each other.

Note

The address and attribute that appear on the remote controller are those of the indoor unit (or OA processing unit) that caused the error.

3. Cause, check method and remedy

	Cause	Check method and remedy
(1)	Drain pump failure	Check for proper functioning of the drain pump mechanism
(2)	Drain water drainage problem •Clogged drain pump •Clogged drain piping	Check for proper drainage.
(3)	Stuck float switch Check for slime in the moving parts of the float switch.	Check for normal operation of the float switch.
(4)	Float switch failure	Check the resistance with the float switch turned on and turned off.
(5)	Indoor unit control board failure •Drain pump drive circuit failure •Float switch input circuit failure	Replace indoor unit control board.
(6)	Items (1) through (5) above and an indoor unit electronic valve closure failure (leaky valve) occurred simultaneously.	Check the solenoid valves on the indoor unit for leaks.

1. Error Code

2503

Drain sensor (Thd) fault

2. Error definition and error detection method

- ♦If the open or short circuit of the thermistor has been detected for 30 seconds, this condition is considered to be a preliminary error, and the unit goes into the 3-minute restart delay mode.
 - ♦If another episode of the above condition is detected during the preliminary error, this is considered a drain sensor error.(If the short or open circuit of the thermistor is no longer detected, normal operation will be restored in 3 minutes.)
 - ♦This error is detected when one of the following conditions are met.
 - *During Cool/Dry operation
 - *Liquid pipe temperature minus inlet temperature is equal to or smaller than - 10°C[-18°F] (except during the defrost cycle)
 - *When the liquid temperature thermistor or suction temperature thermistor or short or open circuited.
 - *Drain pump is in operation.
 - *One hour has elapsed since the drain sensor went off.
- Short: 90 °C [194 °F] or above
 Open: - 20 °C [-4 °F] or below

3. Cause, check method and remedy

Cause	Check method and remedy
(1) Faulty connector (CN31) insertion.	1) Check for connector connection failure. Reinsert the connector, restart the operation, and check for proper operation.
(2) Broken or semi-broken thermistor wire	2) Check for a broken thermistor wire.
(3) Thermistor failure	3) Check the resistance of the thermistor. 0°C[32 °F]:6.0kΩ 10°C[50 °F]:3.9kΩ 20°C[68°F]:2.6kΩ 30°C[86°F]:1.8kΩ 40°C[104 °F]:1.3kΩ
(4) Indoor unit control board (error detection circuit) failure	4) Replace the indoor unit control board if the problem recurs when the unit is operated with the No.-1 and No.-2 pins on the drain sensor connector (CN31) being short-circuited. If the above item checks out OK, there are no problems with the drain sensor. Turn off the power and turn it back on.

1. Error Code

2600

Water leakage

2. Cause, check method and remedy

Check that water does not leak from the pipes in such as the humidifier.

1. Error Code

2601

Water supply cutoff

2. Cause, check method and remedy

Cause	Check method and remedy
(1) The water tank of the humidifier is empty.	Check the amount of supply water. Check for the solenoid valve and for the connection.
(2) The solenoid valve for humidification is OFF.	Check the connector.
(3) Disconnected float switch	Check the connecting part.
(4) Poor operation of float switch	Check for the float switch.
(5) Frozen water tank	Turn off the power source of the water tank to defrost, and turn it on again.

1. Error Code

2602

Function setting error

2. Cause, check method and remedy

Cause	Check method and remedy
(1) The function selection switch on the LOSS-NAY unit (SW5-5) is set to ON.	Set the function selection switch (SW5-5) on the LOSSNAY unit to OFF.

1. Error Code

4102 (TLMU-A1)

Open phase

2. Error definition and error detection method

An open phase of the power supply was detected at power on.

Note

The open phase of the power supply may not always be detected if a power voltage from another circuit is applied.

3. Cause, check method and remedy

Cause		Check method and remedy
(1)	Power supply problem •Open phase voltage of the power supply •Power supply voltage drop	Check the input voltage to the power supply terminal block TB1.
(2)	Noise filter problem •Coil problem •Circuit board failure	•Check the coil connections. •Check for coil burnout. •Check that the voltage across TB21 and TB23 on the noise filter board is 188V or above. •Confirm that the voltage at the CN012 connector is 188 V or above.
(3)	Wiring failure	•Check Noise filter CN110, relay connector CNFG2, and control board CN110 connector for damage to wire or for incomplete connection. •Check Noise filter CN012 and control board CNAC connector.
(4)	Blown fuse	Check that F001,F002 on the noise filter is not blown. ->If a blown fuse is found, check for a short-circuiting or earth fault of the actuator and Transformer T04.
(5)	Control board failure	Replace the control board if none of the above is causing the problem.

1. Error Code

4102 (YLMU-A1)

Open phase

2. Error definition and error detection method

- ♦An open phase of the power supply (L1 phase, L2 phase) was detected at power on.
- ♦The L3 phase current is outside of the specified range.

Note

The open phase of the power supply may not always be detected if a power voltage from another circuit is applied.

3. Cause, check method and remedy

Cause	Check method and remedy
(1) Power supply problem ♦Open phase voltage of the power supply ♦Power supply voltage drop	Check the input voltage to the power supply terminal block TB1.
(2) Noise filter problem ♦Coil problem ♦Circuit board failure	♦Check the coil connections. ♦Check for coil burnout. ♦Check that the voltage across TB21 and TB22 on the noise filter board is 414V or above.
(3) Wiring failure	Confirm that the voltage at the control board connector CNAC is 190 V or above. If the voltage is below 190, check the wiring between noise filter CN6, noise filter CN2, transformer box, and control board CNAC. Confirm that the wiring between noise filter TB23 and INV board SC-L3 is put through CT3.
(4) Blown fuse	Check F01 on the control board, F4, and F5 for a blown fuse. ->If a blown fuse is found, check for a short-circuiting or earth fault of the actuator and Transformer T04.
(5) CT3 failure	Replace the inverter if this problem is detected after the compressor has gone into operation.
(6) Control board failure	Replace the control board if none of the above is causing the problem.

1. Error Code

4106

<Transmission power supply fault error detail FF (Heat source unit)>

2. Error definition and error detection method

Transmission power output failure

3. Cause

- 1) Wiring failure
- 2) Transmission power supply cannot output voltage because overcurrent was detected.
- 3) Voltage cannot be output due to transmission power supply problem.
- 4) Transmission voltage detection circuit failure

4. Check method and remedy

Check the items in IX [4] -7- (2) Troubleshooting transmission power circuit of heat source unit on all heat source units in the same refrigerant circuit.

<Transmission power supply fault other than error detail code FF (Heat source unit)>

2. Error definition and error detection method

Transmission power reception failure

3. Cause

One of the heat source units stopped supplying power, but no other heat source units start supplying power.

4. Check method and remedy

Check the items in IX [4] -7- (2) Troubleshooting transmission power circuit of heat source unit on all heat source units in the same refrigerant circuit.

1. Error Code

4109

Indoor unit fan operation error

2. Error definition and error detection method

During operation, it has been continuously detected for 100 seconds that the auxiliary relay (X13) for fan fault detection is not excited.

3. Cause, check method and remedy

	Cause	Check method and remedy
(1)	Auxiliary relay (X13) fault	Coil failure, disconnected coil
(2)	Connector (CN28) is disconnected.	Check the connector for proper connection.
(3)	Blown fuse	Check the fuse on the control circuit board.
(4)	Motor error (thermistor error inside the motor)	Check the unit fan for proper operation in the test run mode. If no problems are found with items 1 through 3 above and the fan does not operate, replace the motor.

1. Error Code

4115 (TLMU-A1)

Power supply signal sync error

2. Error definition and error detection method

The frequency cannot be determined when the power is switched on.

3. Cause, check method and remedy

Cause		Check method and remedy
(1)	Power supply error	Check the voltage of the power supply terminal block (TB1).
(2)	Noise filter problem •Coil problem •Circuit board failure	<ul style="list-style-type: none"> •Check the coil connections. •Check for coil burnout. •Check that the voltage across TB21 and TB23 on the noise filter board is 188V or above. •Confirm that the voltage at the CN012 connector is 188 V or above.
(3)	Faulty wiring	<ul style="list-style-type: none"> •Check that F001,F002,on the noise filter is not blown. •Check fuse F01 on the control board.
(4)	Wiring failure Between noise filter board CN012 and control board CNAC	Confirm that the voltage at the control board connector CNAC is 188 V or above.
(5)	Control board failure	If none of the items described above is applicable, and if the trouble reappears even after the power is switched on again, replace the control board.

1. Error Code

4115 (YLMU-A1)

Power supply signal sync error

2. Error definition and error detection method

The frequency cannot be determined when the power is switched on.

3. Cause, check method and remedy

Cause		Check method and remedy
(1)	Power supply error	Check the voltage of the power supply terminal block (TB1).
(2)	Noise filter problem •Coil problem •Circuit board failure	<ul style="list-style-type: none"> •Check the coil connections. •Check for coil burnout. •Check that the voltage across TB21 and TB22 on the noise filter board is 414V or above.
(3)	Faulty wiring	Check F01 on the control board, F4, and F5 for a blown fuse.
(4)	Wiring failure Between noise filter CN2, transformer box, and control board CNAC	Confirm that the voltage at the control board connector CNAC is 190 V or above.
(5)	Control board failure	If none of the items described above is applicable, and if the trouble reappears even after the power is switched on again, replace the control board.

1. Error Code

4116

RPM error/Motor error

2. Error definition and error detection method

♦LOSSNAY

- *The motor keep running even if the power is OFF.
- *The thermal overload relay is ON. (Only for the three-phase model)

♦Indoor unit

If detected less than 180rpm or more than 2000rpm, the indoor unit will restart and keep running for 3 minutes.If detected again, the display will appear.

3. Cause, check method and remedy

	Cause	Check method and remedy
(1)	Board failure	Replace the board.
(2)	Motor malfunction	Check for the motor and the solenoid switch.
(3)	Solenoid switch malfunction	

1. Error Code

4121

Function setting error

2. Error source, cause, check method and remedy

Error source	Cause	Check method and remedy
Outdoor unit	(1) Dip switch setting error on the control board	Check the SW6-1 setting on the control board.
	(2) Connector connection error on the control board	Check that nothing is connected to the connector CNAF on the control board.
	(3) Control board failure	Replace the control board if no problems are found with the two items above.

1. Error Code

4124

Electric system not operate due to damper abnormality

2. Error definition and error detection method

When the damper is not located at the designated position.

3. Cause, check method and remedy

When the damper is not located at the designated position.

- 1) Check there is something that interferes the opening or closing movement of the damper.
- 2) If damper does not open or close, turn OFF the power supply and measure the resistance of the damper lock motors (ML1, ML2) and the damper motor (MV2).

The resistance value is normal each. →Replace the indoor electronic control P.C. board.

The resistance value is not normal each. →Replace the motor that indicates the abnormal value.

Part name	Check method and criteria	Figure				
Damper lock motor Right(ML1)	Measure the resistance between the terminals with a tester. (Part temperature: 10°C ~ 30°C)					
Damper lock motor Left(ML2)	<table border="1"> <tr> <td>Color of the lead wire</td> <td>Normal</td> </tr> <tr> <td>BRN-other one</td> <td>235Ω~255Ω</td> </tr> </table>		Color of the lead wire	Normal	BRN-other one	235Ω~255Ω
Color of the lead wire	Normal					
BRN-other one	235Ω~255Ω					
Damper motor (MV2)	<table border="1"> <tr> <td>Color of the lead wire</td> <td>Normal</td> </tr> <tr> <td>BRN-other one</td> <td>282Ω~306Ω</td> </tr> </table>	Color of the lead wire	Normal	BRN-other one	282Ω~306Ω	
Color of the lead wire	Normal					
BRN-other one	282Ω~306Ω					

- 3) If damper opens or closes, measure the voltage between CN1X1 (+) and (-) and the voltage between CN1Y1 (+) and (-) during the damper open by pressing VANE CONTROL button.
 There is not 0V DC between CN1X1 (+) and (-). →Replace the damper limit switch (open)
 There is not 5V DC between CN1X1 (+) and (-). →Replace the damper limit switch (close)
- 4) If damper opens or closes and voltages in 3) are normal, measure the voltage between CN1X1 (+) and (-) and the voltage between CN1Y1 (+) and (-) during the damper close by pressing VANE CONTROL button.
 There is not 5V DC between CN1X1 (+) and (-). →Replace the damper limit switch (open)
 There is not 0V DC between CN1X1 (+) and (-). →Replace the damper limit switch (close)
 There is 5V DC between CN1X1 (+) and (-) and 0V DC between CN1X1 (+) and (-). →Replace the indoor electronic control P.C. board.

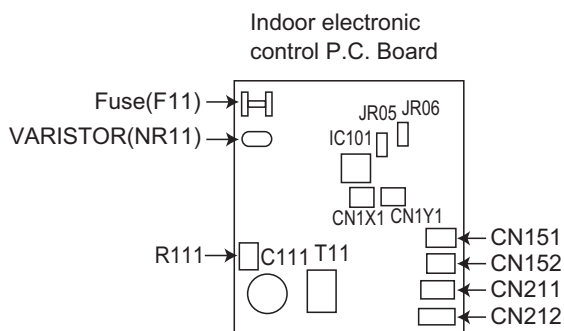

1. Error Code

4220 (TLMU-A1)

Abnormal bus voltage drop (Detail code 108)

2. Error definition and error detection method

If Vdc 160V or less is detected during Inverter operation. (S/W detection)

3. Cause, check method and remedy

(1) Power supply environment

Check whether the unit makes an instantaneous stop when the detection result is abnormal or a power failure occurs.

Check whether the power voltage is 188V or less across all phases.

(2) Voltage drop detected

P72, 96, 120 models

• Check the voltage between the tab terminal TB-P and TB-N on the INV board while the inverter is stopped. -> Check the following items if it is 253V or above.

1) Confirm on the LED monitor that the bus voltage is above 160 V. Replace the INV board if it is below 160 V.

2) Check the voltage at CNRYA on the control board. ->Go to (3).

3) Check the coil connections (L1 - L3) and for coil burnout.

4) Check the wiring connections between the following sections

Between the noise filter board and INV board. Between the INV board and DCL.

Replace the noise filter board if no problems are found.-> Check the following items if the voltage is below 253V.

1) Check the coil connections (L1 - L3) and for coil burnout.

2) Check the wiring between the noise filter board and INV board.

3) Check the connection to SC-P1 and SC-P2 on the INV board.

4) Check the in-rush current resistor value. Replace the INV board if no problems are found.

P144, 168, 192 models

• Check the voltage between the tab terminal SCP1 on the INV board and the terminal N on the IPM while the inverter is stopped.

-> Check the following items if it is 253V or above.

1) Confirm on the LED monitor that the bus voltage is above 160 V. Replace the INV board if it is below 160 V.

2) Check the voltage at CNRYA on the control board. ->Go to (3).

3) Check the coil connections (L1 - L3) and for coil burnout.

4) Check the resistance of the diode stack.IX [4] -6- (8)

5) Check the wiring connections between the following sections

Between the noise filter board and INV board. Between the INV board and C1.

Replace noise filter board if no problems are found.

-> Check the following items if the voltage is below 253V.

1) Check the connection to SCP1 on the INV board and the terminal N on the IPM.

2) Check the wiring between the noise filter board and INV board.

3) Check the resistance of the diode stack.IX [4] -6- (8)

4) Check the in-rush current resistor value.IX [4] -6- (5)

5) Replace the noise filter board.

P216, 240 models

• Check the voltage between the tab terminal SC-C and SC-N1 on the INV board while the inverter is stopped.

Check the following items if it is 253V or above.

1) Confirm on the LED monitor that the bus voltage is above 160 V.

Replace the INV board if it is below 160 V.

2) Check the coil connections (L) and for coil burnout.

3) Check the wiring connections between the following sections.

Noise filter board-INV board, INV board-capacitor board (copper bar).

4) Change INV board if the same error occurs after restart.

Check the following items if the voltage is below 253V.

1) Check the coil connections (L) and for coil burnout.

2) Check the wiring connections between the following sections.

Noise filter board-INV board, INV board-capacitor board (copper bar).

3) Check the in-rush current resistor value.

4) Change INV board if the same error occurs after restart.

(3) Control board failure

Check that 12 VDC is applied to connector CNRYA on the control board while the inverter is operating.

If voltage is absent or the wrong voltage is applied, check the fuse F01. Replace the control board if no problems are found with the fuse.

Note

Refer to section -6- "Inverter (TLMU-A1)" under part [4] Troubleshooting Principal Parts for error codes related to the inverter.

1. Error Code

4220 (YLMU-A1)

Abnormal bus voltage drop (Detail code 108)

2. Error definition and error detection method

If Vdc 289V or less is detected during Inverter operation. (S/W detection)

3. Cause, check method and remedy

(1) Power supply environment

Check whether the unit makes an instantaneous stop when the detection result is abnormal or a power failure occurs.
Check whether the power voltage (Between L1 and L2, L2 and L3, and L1 and L3) is 414V or less across all phases.

(2) Voltage drop detected

4220

♦Check the voltage between the FT-P and FT-N terminals on the INV board while the inverter is stopped and if it is 420 V or above, check the following items.

- 1) Confirm on the LED monitor that the bus voltage is above 289V.

Replace the INV board if it is below 289 V.

- 2) Check the voltage at CNRYB on the control board. ->Go to (3).
- 3) Check the noise filter coil connections and for coil burnout.
- 4) Check the wiring connections between the following sections

Between the noise filter board and INV board. Between the INV board and DCL.

Replace 72C if no problems are found.

- 5) Check the IGBT module resistance on the INV board (Refer to the Trouble shooting for IGBT module).

♦Check the voltage between the FT-P and FT-N terminals on the INV board while the inverter is stopped and if it is less than 420 V, check the following items.

- 1) Check the coil connections and for coil burnout on the noise filter.
- 2) Check the wiring between the noise filter board and INV board.
- 3) Check the connection to SC-L1 and SC-L2 on the INV board.
- 4) Check the in-rush current resistor value.
- 5) Check the 72C resistance value.
- 6) Check the DCL resistance value.

Replace the INV board if no problems are found.

(3) Control board failure

Check that 12VDC is applied to connector CNRYB on the control board while the inverter is operating. If voltage is absent or the wrong voltage is applied, check the fuse F01. Replace the control board if no problems are found with the fuse.

Note

Refer to section -6- "Inverter (YLMU-A1)" under part [4] Troubleshooting Principal Parts for error codes related to the inverter.

1. **Error Code**

4220 (TLMU-A1)

Abnormal bus voltage rise (Detail code 109)

2. **Error definition and error detection method**

If $V_{dc} \geq 400V$ is detected during inverter operation.

3. **Cause, check method and remedy**

(1) **Different voltage connection**

Check the power supply voltage on the power supply terminal block (TB1).

(2) **INV board failure**

If the problem recurs, replace the INV board.

Note

Refer to section -6- "Inverter (TLMU-A1)" under part [4] Troubleshooting Principal Parts for error codes related to the inverter.

1. **Error Code**

4220 (YLMU-A1)

Abnormal bus voltage rise (Detail code 109)

2. **Error definition and error detection method**

If $V_{dc} \geq 830V$ is detected during inverter operation.

3. **Cause, check method and remedy**

(1) **Different voltage connection**

Check the power supply voltage on the power supply terminal block (TB1).

(2) **INV board failure**

If the problem recurs, replace the INV board.

Note

Refer to section -6- "Inverter (YLMU-A1)" under part [4] Troubleshooting Principal Parts for error codes related to the inverter.

1. **Error Code**

4220 (TLMU-A1)

VDC error (Detail code 110)

2. **Error definition and error detection method**

Bus voltage drop

Bus voltage abnormality If $V_{dc} \geq 400V$ or $V_{dc} \leq 160V$ is detected. (H/W detection)

3. **Cause, Check method and remedy**

Same as detail code No.108 and 109 of 4220 error

Note

Refer to section -6- "Inverter (TLMU-A1)" under part [4] Troubleshooting Principal Parts for error codes related to the inverter.

1. Error Code

4220 (TLMU-A1)

Logic error (Detail code 111, 112)(Heat source unit)

2. Error definition and error detection method

H/W error

If only the H/W error logic circuit operates, and no identifiable error is detected.

3. Cause, Check method and remedy

Cause	Check method and remedy
(1) External noise	
(2) INV board failure	Refer to IX [4] -6- (2) [1].

Check the following items on the P144, 168, and 192 systems.

Cause	Check method and remedy
(1) IPM failure	Replace the IPM
(2) DCCT sensor failure	Replace the DCCT sensor

Note

Refer to section -6- "Inverter (TLMU-A1)" under part [4] Troubleshooting Principal Parts for error codes related to the inverter.

1. Error Code

4220 (YLMU-A1)

Logic error (Detail code 111)

2. Error definition and error detection method

H/W error

If only the H/W error logic circuit operates, and no identifiable error is detected.

3. Cause, Check method and remedy

In the case of 4220

Cause	Check method and remedy
(1) External noise	
(2) INV board failure	Refer to IX [4] -6- (2) [1].

Note

Refer to section -6- "Inverter (YLMU-A1)" under part [4] Troubleshooting Principal Parts for error codes related to the inverter.

1. Error Code

4220 (TLMU-A1)

Pressure rise control error (Detail code 123)(Heat source unit)

2. Error definition and error detection method

When a power source voltage drop or a malfunction of the pressure boost circuit is detected.

3. Cause, check method and remedy

Cause	Check method and remedy
(1) Inverter output related	Refer to IX [4] -6- (2) [1]-[5].

Note

Refer to section -6- "Inverter(TLMU-A1)" under part [4] Troubleshooting Principal Parts for error codes related to the inverter.

1. Error Code

4220 (TLMU-A1)

BUS voltage circuit fault (Detail code 124)(Heat source unit)

2. Error definition and error detection method

When a malfunction of relays (RY2, RY3, or RY4) on the INV board is detected.

3. Cause, check method and remedy

Cause	Check method and remedy
(1) Contact failure	Refer to IX [4] -6- (2) [4].
(2) Inverter output related	Refer to IX [4] -6- (2) [1]-[5].

Note

Refer to section -6- "Inverter(TLMU-A1)" under part [4] Troubleshooting Principal Parts for error codes related to the inverter.

1. Error Code

4220

Low bus voltage at startup (Detail code 131)

2. Error definition and error detection method

When $V_{dc} \leq 160$ V is detected just before the inverter operation.

3. Cause, check method and remedy

(1) Inverter main circuit failure

Same as detail code 108 of 4220 error

Note

Refer to section -6- "Inverter" under part [4] Troubleshooting Principal Parts for error codes related to the inverter.

1. Error Code

4230 (TLMU-A1)

Heatsink overheat protection (Detail code 125)

2. Error definition and error detection method

When the heat sink temperature (THHS) remains at or above TOH is detected.

Model	TOH
P72, P96, P120 models	100°C [212°F]
P144, P168, P192 models	90°C [194°F]
P216, P240 models	98°C [208°F]

3. Cause, check method and remedy

Cause	Check method and remedy
(1) Air passage blockage	Check that the heat sink cooling air passage is not blocked
(2) THHS sensor failure	<p>In the case of P72, 96, 120, 216, 240 models</p> <p>1) Check for proper installation of the INV board IGBT. (Check for proper installation of the IGBT heatsink.)</p> <p>2) Check the THHS sensor reading on the LED monitor. ->If an abnormal value appears, replace the INV board.</p> <p>In the case of P144, 168, 192 models</p> <p>3) Check the THHS sensor reading on the LED monitor. ->If an abnormal value appears, check the sensor resistance, and replace the sensor as necessary.</p>

Note

Refer to section -6- "Inverter (TLMU-A1)" under part [4] Troubleshooting Principal Parts for error codes related to the inverter.

1. Error Code

4230 (TLMU-A1)

DCL temperature fault (Detail code 126)(Heat source unit)

2. Error definition and error detection method

When DCL temperature that equals or exceeds 170°C is detected (applicable to P216, 240 models only)

3. Cause, check method and remedy

Cause	Check method and remedy
(1) Air passage blockage	Check the DCL cooling air channel for clogging.
(2) Poor DCL temperature sensor contact	Check the connector (CNTH) on the INV board for proper connection.
(3) DCL error	Change DCL if the same error occurs after restart.

Note

Refer to section -6- "Inverter (TLMU-A1)" under part [4] Troubleshooting Principal Parts for error codes related to the inverter.

1. Error Code

4230 (YLMU-A1)

Heatsink overheat protection

2. Error definition and error detection method

When the heat sink temperature (THHS) remains at or above TOH is detected.

Model	TOH
PQHY	105°C [221°F]
PQRY	100°C [212°F]

3. Cause, check method and remedy

Cause	Check method and remedy
(1) Air passage blockage	Check that the heat sink cooling air passage is not blocked
(2) THHS failure	1) Check for proper installation of the INV board IGBT. (Check for proper installation of the IGBT heatsink.) 2) Check the THHS sensor reading on the LED monitor. ->If an abnormal value appears, replace the INV board.

Note

Refer to section -6- "Inverter (YLMU-A1)" under part [4] Troubleshooting Principal Parts for error codes related to the inverter.

1. Error Code

4240 (TLMU-A1)

Overload protection

2. Error definition and error detection method

If the output current of "(Iac) > Imax (Arms)" or "THHS > TOL" is continuously detected for 10 minutes during inverter operation. Refer to the relevant pages for the details of model names and the specified values.

3. Cause, check method and remedy

Cause	Check method and remedy
(1) Air passage blockage	Check that the heat sink cooling air passage is not blocked
(2) Power supply environment	Power supply voltage is 188 V or above.
(3) Inverter failure	Refer to IX [4] -6-.
(4) Current sensor (ACCT) failure	Refer to IX [4] -6-(5).
(5) Compressor failure	Check that the compressor has not overheated during operation. -> Check the refrigerant circuit (oil return section). Refer to IX [4] -6- (2) [2].

Note

Refer to section -6- "Inverter (TLMU-A1)" under part [4] Troubleshooting Principal Parts for error codes related to the inverter.

1. Error Code

4240 (YLMU-A1)

Overload protection

2. Error definition and error detection method

If the output current of "(Iac) > I_{max} (Arms)" or "THHS > TOL" is continuously detected for 10 minutes during inverter operation. Refer to the relevant pages for the details of model names and the specified values.

3. Cause, check method and remedy

Cause	Check method and remedy
(1) Air passage blockage	Check that the heat sink cooling air passage is not blocked
(2) Power supply environment	Power supply voltage is 414 V or above.
(3) Inverter failure	Refer to IX [4] -6-.
(4) Compressor failure	Check that the compressor has not overheated during operation. -> Check the refrigerant circuit (oil return section). Refer to IX [4] -6- (2) [2].

Note

Refer to section -6- "Inverter (YLMU-A1)" under part [4] Troubleshooting Principal Parts for error codes related to the inverter.

1. Error Code

4250 (TLMU-A1)

IPM error (Detail code 101)(Heat source unit)

2. Error definition and error detection method

In the case of P72, 96, 120 models

Overcurrent is detected by the overcurrent detection resistor (RSH) on the INV board.

In the case of P144, 168, 192 models

IPM error signal is detected.

In the case of P216, 240 models

Overcurrent is detected by the DCCT sensor on the INV board.

3. Cause, check method and remedy

In the case of P72, 96, 120, 216, 240 models

Cause	Check method and remedy
(1) Inverter output related	Refer to IX [4] -6- (2) [1]-[5].

In the case of P144, 168, 192 models

Cause	Check method and remedy
(1) Inverter output related	Refer to IX [4] -6- (2) [1]-[5].
(2) Same as 4230 error	Same as 4230 error

Note

Refer to section -6- "Inverter (TLMU-A1)" under part [4] Troubleshooting Principal Parts for error codes related to the inverter.

1. Error Code

4250 (YLMU-A1)

IPM error (Detail code 101)

2. Error definition and error detection method

Overcurrent is detected by the overcurrent detection resistor (RSH) on the INV board.

3. Cause, check method and remedy

Cause	Check method and remedy
(1) Inverter output related	Refer to IX [4] -6- (2) [1]-[4]. Check the IGBT module resistance value of the INV board, if no problems are found. (Refer to the Trouble shooting for IGBT module)

Note

Refer to section -6- "Inverter (YLMU-A1)" under part [4] Troubleshooting Principal Parts for error codes related to the inverter.

1. Error Code

4250 (TLMU-A1)

DCCT overcurrent (Detail code 103) (Heat source unit)

Instantaneous overcurrent (Detail code 106)

Overcurrent (Detail code 107)

2. Error definition and error detection method

When a DCL overcurrent is detected by the current sensor.

Refer to the relevant pages for the details of model names and the specified values.

3. Cause, check method and remedy

Cause	Check method and remedy
(1) Inverter output related	Refer to IX [4] -6- (2) [1]-[5]. Check the IGBT module resistance value of the INV board if no problems are found. (Refer to "Troubleshooting" for IGBT module related problems)

Note

Refer to section -6- "Inverter (TLMU-A1)" under part [4] Troubleshooting Principal Parts for error codes related to the inverter.

1. Error Code

4250 (YLMU-A1)

Instantaneous overcurrent (Detail code 106)

Overcurrent (Detail code 107)

2. Error definition and error detection method

When a DCL overcurrent is detected by the current sensor.

Refer to the relevant pages for the details of model names and the specified values.

3. Cause, check method and remedy

Cause	Check method and remedy
(1) Inverter output related	Refer to IX [4] -6- (2) [1]-[4]. Check the IGBT module resistance value of the INV board if no problems are found. (Refer to "Troubleshooting" for IGBT module related problems)

Note

Refer to section -6- "Inverter (YLMU-A1)" under part [4] Troubleshooting Principal Parts for error codes related to the inverter.

1. Error Code

4250

Short-circuited IPM/Ground fault (Detail code 104)

2. Error definition and error detection method

When IPM/IGBT short damage or grounding on the load side is detected just before starting the inverter.

3. Cause, check method and remedy

Cause	Check method and remedy
(1) Grounding fault compressor	Refer to IX [4] -6- (2) [2].
(2) Inverter output related	Refer to IX [4] -6- (2) [1]-[4].

Note

Refer to section -6- "Inverter" under part [4] Troubleshooting Principal Parts for error codes related to the inverter.

1. Error Code

4250

Overcurrent error due to short-circuited motor (Detail code 105)

2. Error definition and error detection method

When a short is detected on the load side just before starting the inverter operation.

3. Cause, Check method and remedy

Cause	Check method and remedy
(1) Short - circuited compressor	Refer to IX [4] -6- (2) [2].
(2) Output wiring	Check for a short circuit.

Note

Refer to section -6- "Inverter" under part [4] Troubleshooting Principal Parts for error codes related to the inverter.

1. Error Code

4250 (TLMU-A1)

DCL overcurrent (H/W detection) (Detail code 121, 128)(Heat source unit)

DCL overcurrent (S/W detection) (Detail code 122)(Heat source unit)

2. Error definition and error detection method

When a DCL overcurrent is detected by the current sensor.

Refer to the relevant pages for the details of model names and the specified values.

3. Cause, Check method and remedy

Cause	Check method and remedy
(1) Inverter output related	Refer to IX [4] -6- (2) [1]-[5].

Note

Refer to section -6- "Inverter(TLMU-A1)" under part [4] Troubleshooting Principal Parts for error codes related to the inverter.

1. Error Code

4260 (TLMU-A1)

Heatsink overheat protection at startup

2. Error definition and error detection method

The heatsink temperature (THHS) remains at or above TOH for 10 minutes or more at inverter startup.

Model	TOH
P72, P96, P120 models	100°C [212°F]
P144, P168, P192 models	90°C [194°F]
P216, P240 models	98°C [208°F]

3. Cause, check method and remedy

Same as 4230 error

Note

Refer to section -6- "Inverter (TLMU-A1)" under part [4] Troubleshooting Principal Parts for error codes related to the inverter.

1. Error Code

4260 (YLMU-A1)

Heatsink overheat protection at startup

2. Error definition and error detection method

The heatsink temperature (THHS) remains at or above TOH for 10 minutes or more at inverter startup.

Model	TOH
PQHY	105°C [221°F]
PQRY	100°C [212°F]

3. Cause, check method and remedy

Same as 4230 error

Note

Refer to section -6- "Inverter (YLMU-A1)" under part [4] Troubleshooting Principal Parts for error codes related to the inverter.

1. Error Code

5101

**Return air temperature sensor (TH21) fault (Indoor unit)
Return air temperature sensor (TH4) fault (OA processing unit)**

5102

**Pipe temperature sensor (TH22) fault (Indoor unit)
Pipe temperature sensor (TH2) fault (OA processing unit)**

5103

**Gas-side pipe temperature sensor (TH23) fault (Indoor unit)
Gas-side pipe temperature sensor (TH3) fault (OA processing unit)**

5104

**Intake air temperature sensor (TH1) fault (OA processing unit)
Intake air temperature sensor (TH24) fault (All-fresh (100% outdoor air) type indoor unit)**

2. Error definition and error detection method

♦If a short or an open is detected during thermostat ON, the heat source unit turns to anti-restart mode for 3 minutes. When the error is not restored after 3 minutes (if restored, the heat source unit runs normally), the heat source unit makes an error stop.

Short: detectable at 90°C [194°F] or higher

Open: detectable at -40°C [-40°F] or lower

♦Sensor error at gas-side cannot be detected under the following conditions.

*During heating operation

*During cooling operation for 3 minutes after the compressor turns on.

3. Cause, check method and remedy

Cause		Check method and remedy
(1)	Thermistor failure	Check the thermistor resistor. 0°C [32°F]: 15 kohm 10°C [50°F]: 9.7 kohm 20°C [68°F] : 6.4 kohm 30°C [86°F] : 4.3 kohm 40°C [104°F] : 3.1 kohm
(2)	Connector contact failure	
(3)	Disconnected wire or partial disconnected thermistor wire	
(4)	Unattached thermistor or contact failure	
(5)	Indoor board (detection circuit) failure	
		Check the connector contact. When no fault is found, the indoor board is a failure.

1. Error Code

5102

HIC bypass circuit outlet temperature sensor (TH2) fault (Heat source unit)

5103

Heat exchanger outlet temperature sensor (TH3) fault (Heat source unit)

5104

Discharge temperature sensor (TH4) fault (Heat source unit)

5105

Accumulator inlet temperature sensor (TH5) fault (Heat source unit)

5106

HIC circuit outlet temperature sensor (TH6) fault (Heat source unit)

5107

Outside temperature sensor (TH7) fault (Heat source unit)

2. Error definition and error detection method

- ♦When a short (high temperature intake) or an open (low temperature intake) of the thermistor is detected (the first detection), the heat source unit stops, turns to anti-restart mode for 3 minutes, and restarts when the detected temperature of the thermistor.
- ♦When a short or an open is detected again (the second detection) after the first restart of the heat source unit, the heat source unit stops, turns to anti-restart mode for 3 minutes, and restarts in 3 minutes when the detected temperature is within the normal range.
- ♦When a short or an open is detected again (the third detection) after the previous restart of the heat source unit, the heat source unit makes an error stop.
- ♦When a short or an open of the thermistor is detected just before the restart of the heat source unit, the heat source unit makes an error stop, and the error code "5102", "5103", "5104", "5105", "5106" or "5107" will appear.
- ♦During 3-minute antirestart mode, preliminary errors will be displayed on the LED display.
- ♦A short or an open described above is not detected for 10 minutes after the compressor start, during defrost mode, or for 3 minutes after defrost mode.

3. Cause, check method and remedy

Cause	Check method and remedy
(1) Thermistor failure	Check thermistor resistance.
(2) Pinched lead wire	Check for pinched lead wire.
(3) Torn wire coating	Check for wire coating.
(4) A pin on the male connector is missing or contact failure	Check connector.
(5) Disconnected wire	Check for wire.
(6) Thermistor input circuit failure on the control board	Check the intake temperature of the sensor with the LED monitor. When the temperature is far different from the actual temperature, replace the control board.

<Reference>

	Short detection	Open detection
TH2	70 °C [158 °F] and above (0.4 kΩ)	-40 °C [-40 °F] and below (130 kΩ)
TH3	110 °C [230 °F] and above (0.4 kΩ)	-40 °C [-40 °F] and below (130 kΩ)
TH4	240 °C [464 °F] and above (0.57 kΩ)	0 °C [32 °F] and below (698 kΩ)
TH5	70 °C [158 °F] and above (0.4 kΩ)	-40 °C [-40 °F] and below (130 kΩ)
TH6	70 °C [158 °F] and above (1.14 kΩ)	-40 °C [-40 °F] and below (130 kΩ)
TH7	110 °C [230 °F] and above (0.4 kΩ)	-40 °C [-40 °F] and below (130 kΩ)

1. Error Code

5110 (TLMU-A1)

Heatsink temperature sensor (THHS) fault (Detail code 01)

2. Error definition and error detection method

When a short or an open of THHS is detected just before or during the inverter operation.

3. Cause, check method and remedy

In the case of P72, 96, 120, 216, 240 models

Cause	Check method and remedy
(1) INV board failure	If the problem recurs when the unit is put into operation, replace the INV board.

In the case of P144, 168, 192 models

Cause	Check method and remedy
(1) Contact failure	Check the connector connection (CNTH) on the INV board.
(2) THHS sensor failure	Check the THHS sensor reading on the LED monitor. Replace the sensor if it reads below - 30°C [-22°F] or above 150°C[302°F].
(3) INV board failure	If the problem recurs when the unit is put into operation, replace the INV board.

Note

Refer to section -6- "Inverter (TLMU-A1)" under part [4] Troubleshooting Principal Parts for error codes related to the inverter.

1. Error Code

5110 (YLMU-A1)

Heatsink temperature sensor (THHS) fault (Detail code 01)

2. Error definition and error detection method

When a short or an open of THHS is detected just before or during the inverter operation.

3. Cause, check method and remedy

Cause	Check method and remedy
(1) INV board failure	If the problem recurs when the unit is put into operation, replace the INV board.

Note

Refer to section -6- "Inverter (YLMU-A1)" under part [4] Troubleshooting Principal Parts for error codes related to the inverter.

1. Error Code

5120 (TLMU-A1)

DCL temperature sensor circuit fault (Detail code 01)

2. Error definition and error detection method

When an open or short-circuiting of the temperature sensor is detected immediately before inverter starts up or during operation (Applicable to P216, 240 only)

3. Cause, check method and remedy

Cause	Check method and remedy
(1) Contact failure	Check the connector connection (CNTH) on the INV board.
(2) DCL temperature sensor failure	Remove the connector (CNTH), and measure the DCL temperature sensor resistance.
(3) INV board failure	If the problem recurs when the unit is put into operation, replace the INV board.

Note

Refer to section -6- "Inverter (TLMU-A1)" under part [4] Troubleshooting Principal Parts for error codes related to the inverter.

1. Error Code

5201

High-pressure sensor fault (63HS1)

2. Error definition and error detection method

- ♦If the high pressure sensor detects 0.098MPa [14psi] or less during the operation, the heat source unit stops once, turns to anti-restart mode for 3 minutes, and restarts after 3 minutes when the detected high pressure sensor is 0.098MPa [14psi] or more.
- ♦If the high pressure sensor detects 0.098MPa [14psi] or less just before the restart, the heat source unit makes an error stop, and the error code "5201" will appear.
- ♦During 3-minute antirestart mode, preliminary errors will be displayed on the LED display.
- ♦A error is not detected for 3 minutes after the compressor start.

3. Cause, check method and remedy

Cause	Check method and remedy
(1) High pressure sensor failure	Refer to the page on the troubleshooting of the high pressure sensor. (IX [4] -1-)
(2) Pressure drop due to refrigerant leak	
(3) Torn wire coating	
(4) A pin on the male connector is missing or contact failure	
(5) Disconnected wire	
(6) High pressure sensor input circuit failure on the control board	

1. Error Code

5301 (TLMU-A1)

ACCT sensor fault (Detail code 115)

2. Error definition and error detection method

When the formula "output current < 2 Arms" remains satisfied for 10 seconds while the inverter is in operation.

3. Cause, check method and remedy

In the case of P72, P96, 120, 216, 240 models

Cause	Check method and remedy
(1) Inverter open output phase	Check the output wiring connections.
(2) Compressor failure	Refer to IX [4] -6- (2) [2].
(3) INV board failure	If the problem recurs when the unit is put into operation, replace the INV board.

In the case of P144, P168, 192 models

Cause	Check method and remedy
(1) Contact failure	Check the connector connection (CNCT2) on the INV board.
(2) Inverter open output phase	Check the output wiring connections.
(3) ACCT sensor failure	Refer to IX [4] -6- (5).
(4) Compressor failure	Refer to IX [4] -6- (2) [2].
(5) INV board failure	If the problem recurs when the unit is put into operation, replace the INV board.

Note

Refer to section -6-"Inverter (TLMU-A1)" under part [4] Troubleshooting Principal Parts for error codes related to the inverter.

1. Error Code

5301 (YLMU-A1)

ACCT sensor fault (Detail code 115)

2. Error definition and error detection method

When the formula "output current < 1.8 Arms" remains satisfied for 10 seconds while the inverter is in operation.

3. Cause, check method and remedy

Cause	Check method and remedy
(1) Inverter open output phase	Check the output wiring connections.
(2) Compressor failure	Refer to IX [4] -6- (2) [2].
(3) INV board failure	Refer to IX [4] -6- (2) [1], [3], [4].

Note

Refer to section -6-"Inverter (YLMU-A1)" under part [4] Troubleshooting Principal Parts for error codes related to the inverter.

1. Error Code

5301 (TLMU-A1)

DCCT sensor fault (Detail code 116)

2. Error definition and error detection method

When the bus current less than 18 Apeak is detected at startup (6Hz) (P144, 168, 192 models only)

3. Cause, check method and remedy

Cause	Check method and remedy
(1) Contact failure	Check the connector CNCT on the INV board and the DCCT-side connectors for proper contact.
(2) Misorientation	Check the installation direction of DCCT sensor.
(3) DCCT sensor failure	Replace the DCCT sensor.
(4) INV board failure	If the problem recurs when the unit is put into operation, replace the INV board.

Note

Refer to section -6-"Inverter (TLMU-A1)" under part [4] Troubleshooting Principal Parts for error codes related to the inverter.

1. Error Code

5301

ACCT sensor circuit fault (Detail code 117)

2. Error definition and error detection method

When an error value is detected with the ACCT detection circuit just before the inverter starts

3. Cause, check method and remedy

Cause	Check method and remedy
(1) INV board failure	Refer to IX [4] -6- (2) [1], [3], [4].
(2) Compressor failure	Refer to IX [4] -6- (2) [2].

Note

Refer to section -6-"Inverter" under part [4] Troubleshooting Principal Parts for error codes related to the inverter.

1. Error Code

5301

DCCT sensor circuit fault (Detail code 118)

2. Error definition and error detection method

When an error value is detected with the DCCT detection circuit just before the inverter starts (P144, 168, 192 models only).

3. Cause, check method and remedy

Cause	Check method and remedy
(1) Contact failure	Check the connector CNCT on the INV board and the DCCT-side connectors for proper contact.
(2) INV board failure	Refer to IX [4] -6- (2)[1][3] [4].
(3) DCCT sensor failure	Replace the DCCT sensor.
(4) Compressor failure	Refer to IX [4] -6- (2) [2].
(5) INV board failure	Refer to IX [4] -6-.

Note

Refer to section -6-"Inverter (TLMU-A1)" under part [4] Troubleshooting Principal Parts for error codes related to the inverter.

1. Error Code

5301 (TLMU-A1)

Open-circuited IPM/Loose ACCT connector (Detail code 119)

2. Error definition and error detection method

Presence of enough current cannot be detected during the self-diagnostic operation immediately before inverter startup.

3. Cause, check method and remedy

In the case of P72, P96, 120, 216, 240 models

Cause	Check method and remedy
(1) Inverter output wiring problem	Check output wiring connections. Confirm that the U- and W-phase output cables are put through CT12 and CT22 on the INV board respectively.
(2) INV board failure	Refer to IX [4] -6- (2) [3][4].
(3) Compressor failure	Refer to IX [4] -6- (2) [2].

In the case of P144, P168, 192 models

Cause	Check method and remedy
(1) ACCT sensor disconnection	Check the connector (CNCT2) on the INV board for proper connection. Check the ACCT for proper connection.
(2) ACCT sensor failure	Refer to IX [4] -6- (5).
(3) INV board failure	Refer to IX [4] -6- (2) [3][4].
(4) Compressor failure	Refer to IX [4] -6- (2) [2].

Note

Refer to section -6- "Inverter(TLMU-A1)" under part [4] Troubleshooting Principal Parts for error codes related to the inverter.

1. Error Code

5301 (YLMU-A1)

Open-circuited IPM/Loose ACCT connector (Detail code 119)

2. Error definition and error detection method

Presence of enough current cannot be detected during the self-diagnostic operation immediately before inverter startup.

3. Cause, check method and remedy

Cause	Check method and remedy
(1) Inverter output wiring problem	Check output wiring connections. Confirm that the U- and W-phase output cables are put through CT12 and CT22 on the INV board respectively.
(2) Inverter failure	Refer to IX [4] -6-(2) [3][4].
(3) Compressor failure	Refer to IX [4] -6- (2) [2].

Note

Refer to section -6- "Inverter(YLMU-A1)" under part [4] Troubleshooting Principal Parts for error codes related to the inverter.

1. Error Code

5301 (TLMU-A1)

Faulty ACCT wiring (Detail code 120)

2. Error definition and error detection method

Presence of target current cannot be detected during the self-diagnostic operation immediately before startup. (Detection of improperly mounted ACCT sensor)

3. Cause, check method and remedy

In the case of P72, P96, 120, 216, 240 models

Cause	Check method and remedy
(1) Inverter output wiring problem	Check output wiring connections. P72, 96, 120 models Confirm that the U- and W-phase output cables are put through CT11 and CT12 on the INV board respectively. P216, 240 models Confirm that the U- and W-phase output cables are put through CT1 and CT2 on the INV board respectively.
(2) Inverter failure	Refer to IX [4] -6- (2) [3][4].
(3) Compressor failure	Refer to IX [4] -6- (2) [2].
(4) INV board failure	If no problems are found with the items above, replace the INV board.

In the case of P144, P168, 192 models

Cause	Check method and remedy
(1) Wrongly mounted ACCT sensor	Check for proper mounting of ACCT. Refer to IX [4] -6- (5).
(2) ACCT sensor failure	Refer to IX [4] -6- (5).
(3) INV board failure	Refer to IX [4] -6- (2) [3][4].
(4) Compressor failure	Refer to IX [4] -6- (2) [2].

Note

Refer to section -6- "Inverter(TLMU-A1)" under part [4] Troubleshooting Principal Parts for error codes related to the inverter.

1. Error Code

5301 (YLMU-A1)

Faulty ACCT wiring (Detail code 120)

2. Error definition and error detection method

Presence of target current cannot be detected during the self-diagnostic operation immediately before startup. (Detection of improperly mounted ACCT sensor)

3. Cause, check method and remedy

Cause	Check method and remedy
(1) Inverter output wiring problem	Check output wiring connections. Confirm that the U- and W-phase output cables are put through CT11 and CT12 on the INV board respectively.
(2) Inverter failure	Refer to IX [4] -6- (2) [3][4].
(3) Compressor failure	Refer to IX [4] -6- (2) [2].
(4) INV board failure	If no problems are found with the items above, replace the INV board.

Note

Refer to section -6- "Inverter(YLMU-A1)" under part [4] Troubleshooting Principal Parts for error codes related to the inverter.

1. Error Code

5301 (TLMU-A1)

DCL Current sensor circuit fault (Detail code 127)

2. Error definition and error detection method

When an abnormal value is detected by the DCL current sensor detection circuit

3. Cause, check method and remedy

Cause	Check method and remedy
(1) Contact failure	Check the wiring between CNCT4A and CNCT4B for proper connection.
(2) Misorientation	Check the copper bar between the SC-L terminal and the module for proper mounting.
(3) INV board failure	If the problem recurs when the unit is put into operation, replace the INV board.

Note

Refer to section -6- "Inverter(TLMU-A1)" under part [4] Troubleshooting Principal Parts for error codes related to the inverter.

1. Error Code

5401

Humidity sensor fault

2. Error definition and error detection method

A short-circuit or an open-circuit of the humidity sensor is detected during operation.

3. Cause, check method and remedy

Cause	Check method and remedy
(1) Connector contact failure (CN30) (Loose connector)	1) Check the connector for proper contact. Reconnect the connector, and operate the unit to check for proper operation.
(2) Broken or partially broken humidity sensor wire	2) Check for broken humidity sensor wire.
(3) Humidity sensor fault	3) Check the output voltage across No. 1 and No. 3 pins of connector CN30 with the connector being connected to the indoor unit control board. 30% : 1.25V 40% : 1.52V 50% : 1.88V 60% : 2.19V 70% : 2.48V 80% : 2.79V
(4) Indoor unit control board (detection circuit) fault	4) If the above items check out okay, replace the indoor unit control board.

1. Error Code

5701

Loose float switch connector

2. Error definition and error detection method

Detection of the disconnected float switch (open-phase condition) during operation

3. Cause, check method and remedy

(1) CN4F disconnection or contact failure

Check for disconnection of the connector (CN4F) on the indoor unit control board.

1. Error Code

6201

Remote controller board fault (nonvolatile memory error)

2. Error definition and error detection method

This error is detected when the data cannot be read out from the built-in nonvolatile memory on the remote controller.

3. Cause, check method and remedy

(1) Remote controller failure

Replace the remote controller.

1. Error Code

6202

Remote controller board fault (clock IC error)

2. Error definition and error detection method

This error is detected when the built-in clock on the remote controller is not properly functioning.

3. Cause, check method and remedy

(1) Remote controller failure

Replace the remote controller.

1. Error Code

6600

Address overlaps

2. Error definition and error detection method

An error in which signals from more than one indoor units with the same address are received

Note

The address and attribute that appear on the remote controller indicate the controller that detected the error.

3. Cause, check method and remedy

Cause	Check method and remedy
Two or more of the following have the same address: Heat source units, indoor units, LOSSNAY units, controllers such as M-NET remote controllers. <Example> 6600 "01" appears on the remote controller Unit #01 detected the error. Two or more units in the system have 01 as their address.	Find the unit that has the same address as that of the error source. Once the unit is found, correct the address. Then, turn off the heat source units, indoor units, and LOSSNAY units, keep them all turned off for at least five minutes, and turn them back on.

1. Error Code

6601

Polarity setting error

2. Error definition and error detection method

The error detected when transmission processor cannot distinguish the polarities of the M-NET transmission line.

3. Cause, check method and remedy

Cause	Check method and remedy
(1) No voltage is applied to the M-NET transmission line.	Check if power is supplied to the M-NET transmission line and correct any problem found.
(2) M-NET transmission line is short-circuited.	

1. Error Code

6602

Transmission processor hardware error

2. Error definition and error detection method

Although "0" was surely transmitted by the transmission processor, "1" is displayed on the transmission line.

Note

The address/attribute appeared on the display on the remote controller indicates the controller where an error occurred.

3. Cause

- 1) When the wiring work of or the polarity of either the indoor or heat source transmission line is performed or is changed while the power is on, the transmitted data will collide, the wave shape will be changed, and an error will be detected.
- 2) Grounding fault of the transmission line
- 3) When grouping the indoor units that are connected to different heat source units, the male power supply connectors on the multiple heat source units are connected to the female power supply switch connector (CN40).
- 4) When the power supply unit for transmission lines is used in the system connected with MELANS, the male power supply connector is connected to the female power supply switch connector (CN40) on the heat source unit.
- 5) Controller failure of the source of the error
- 6) When the transmission data is changed due to the noise on the transmission line
- 7) Voltage is not applied on the transmission line for centralized control (in case of grouped indoor units connected to different heat source units or in case of the system connected with MELANS)

4. Check method and remedy

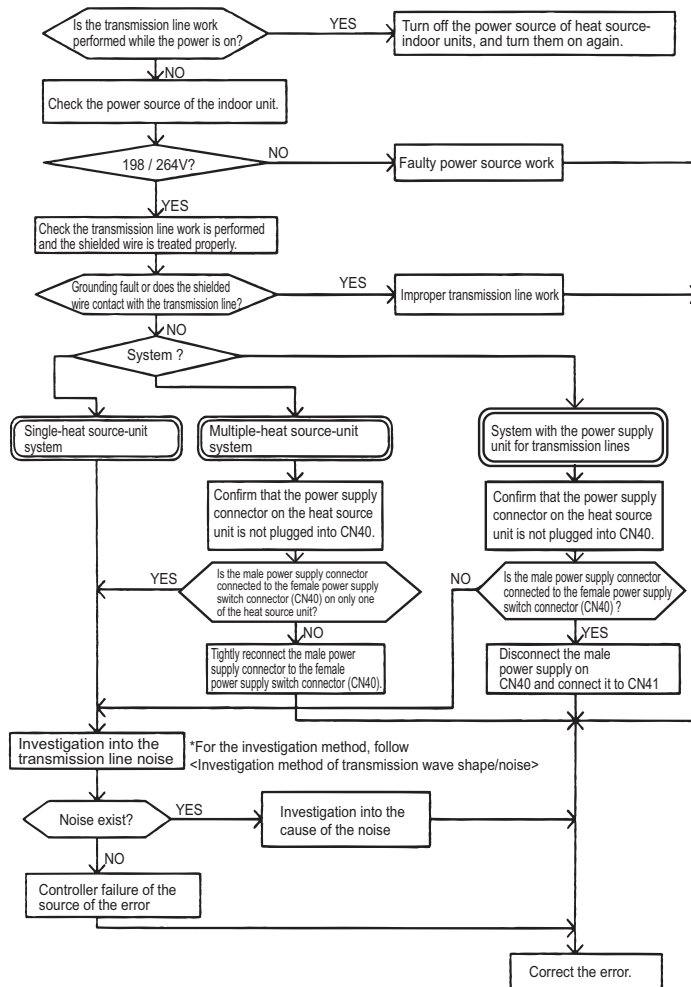

1. Error Code

6603

Transmission line bus busy error

2. Error definition and error detection method

- ♦Generated error when the command cannot be transmitted for 4-10 minutes in a row due to bus-busy
- ♦Generated error when the command cannot be transmitted to the transmission line for 4-10 minutes in a row due to noise

Note

The address/attribute appeared on the display on the remote controller indicates the controller where an error occurred.

3. Cause, check method and remedy

Cause	Check method and remedy
(1) The transmission processor cannot be transmitted as the short-wavelength voltage like noise exists consecutively on the transmission line.	No noise indicates that the error source controller is a failure. If noise exists, investigate the noise. -> No noise indicates that the error source controller is a failure. -> If noise exists, investigate the noise.
(2) Error source controller failure	

1. Error Code

6606

Communication error between device and transmission processors

2. Error definition and error detection method

Communication error between the main microcomputer on the indoor unit board and the microcomputer for transmission

Note

The address/attribute appeared on the display on the remote controller indicates the controller where an error occurred.

3. Cause, check method and remedy

Cause	Check method and remedy
(1) Data is not properly transmitted due to accidental erroneous operation of the controller of the error source.	Turn off the power source of the heat source and the indoor units.(When the power source is turned off separately, the microcomputer will not be reset, and the error will not be corrected.) -> If the same error occurs, the error source controller is a failure.
(2) Error source controller failure	

1. Error Code

6607

No ACK error

2. Error definition and error detection method

The error is detected when no acknowledgement (ACK signal) is received after the transmission. (eg. When the data is transmitted six times in a row with 30 seconds interval, the error is detected on the transmission side.)

Note

The address/attribute appeared on the display on the remote controller indicates the controller which did not provide the response (ACK).

3. System configuration

(1) System with one heat source unit

Error source address	Error display	Detection method	Cause	Check method and remedy
Heat source unit (OC)	ME remote controller (RC) MA remote controller (MA)	No acknowledgement (ACK) at IC transmission to OC	(1) Contact failure of transmission line of OC or IC (2) Decrease of transmission line voltage/signal by exceeding acceptable range of transmission wiring. Farthest:200 m [656ft] or less Remote controller wiring: 10m [32ft] or less (3) Erroneous sizing of transmission line (Not within the range below). Wire diameter: 1.25mm ² [AWG16] or more (4) Heat source unit control board failure	Turn off the power source of the heat source unit, and turn it on again. If the error is accidental, it will run normally. If not, check the causes (1) - (4).
BC controller (BC)	ME remote controller (RC) MA remote controller (MA)	No acknowledgement (ACK) at IC transmission to BC	(1) When BC controller address is changed or modified during operation. (2) Faulty or disconnected transmission wiring of BC controller (3) Disconnected connector of BC controller (CN02) (4) Faulty control board of BC controller	Turn off the heat source-indoor units for 5 or more minutes, and turn them on again. If the error is accidental, they will run normally. If not, check the causes (1) - (4).
Indoor unit (IC)	ME remote controller (RC) MA remote controller (MA)	No acknowledgement (ACK) at RC transmission to IC	(1) When IC unit address is changed or modified during operation. (2) Faulty or disconnected IC transmission wiring (3) Disconnected IC connector (CN2M) (4) Indoor unit controller failure (5) ME remote controller failure	Turn off the heat source-indoor units for 5 or more minutes, and turn them on again. If the error is accidental, they will run normally. If not, check the causes (1) - (5).
LOSSNAY (LC)	ME remote controller (RC) MA remote controller (MA)	No acknowledgement (ACK) at IC transmission to LC	(1) The power source of LOSSNAY has been shut off. (2) When the address of LOSSNAY is changed in the middle of the operation (3) Faulty or disconnected transmission wiring of LOSSNAY (4) Disconnected connector (CN1) on LOSSNAY (5) Controller failure of LOSSNAY	Turn off the power source of LOSSNAY and turn it on again. If the error is accidental, it will run normally. If not, check the causes (1) - (5).
ME remote controller (RC)	ME remote controller (RC) MA remote controller (MA)	No acknowledgement (ACK) at IC transmission to RC	(1) Faulty transmission wiring at IC unit side. (2) Faulty wiring of the transmission line for ME remote controller (3) When the address of ME remote controller is changed in the middle of the operation (4) ME remote controller failure	Turn off the power source of the heat source unit for 5 minutes or more, and turn it on again. If the error is accidental, it will run normally. If not, check the causes (1) - (4).

1. Error Code

6607

No ACK error

2. Error definition and error detection method

The error is detected when no acknowledgement (ACK signal) is received after the transmission. (eg. When the data is transmitted six times in a row with 30 seconds interval, the error is detected on the transmission side.)

Note

The address/attribute appeared on the display on the remote controller indicates the controller which did not provide the response (ACK).

3. System configuration

(2) Grouping of units in a system with multiple heat source units

Error source address	Error display	Detection method	Cause	Check method and remedy
Heat source unit (OC)	ME remote controller (RC) MA remote controller (MA)	No acknowledgement (ACK) at IC transmission to OC	Same cause as that for system with one heat source unit	Same remedy as that for system with one heat source unit
BC controller (BC)	ME remote controller (RC) MA remote controller (MA)	No acknowledgement (ACK) at IC transmission to BC	Same cause as that for system with one heat source unit	Same remedy as that for system with one heat source unit
Indoor unit (IC)	ME remote controller (RC) MA remote controller (MA)	No acknowledgement (ACK) at RC transmission to IC	<p>(1) Same causes as (1) - (5) for system with one heat source unit</p> <p>(2) Disconnection or short circuit of the transmission line for the heat source unit on the terminal block for centralized control line connection (TB7)</p> <p>(3) When multiple heat source units are connected and the power source of one of the heat source units has been shut off.</p> <p>(4) The male power supply connector of the heat source unit is not connected to the female power supply switch connector (CN40).</p> <p>(5) The male power supply connectors on 2 or more heat source units are connected to the female power supply switch connector (CN40) for centralized control.</p> <p>If an error occurs, after the unit runs normally once, the following causes may be considered.</p> <ul style="list-style-type: none"> •Total capacity error (7100) •Capacity code error (7101) •Error in the number of connected units (7102) •Address setting error (7105) 	<p>1) Turn off the power sources of the heat source and indoor units for 5 or more minutes, and turn them on again. If the error is accidental, the will run normally.If not, check the cause 2).</p> <p>2) Check the causes of (1) - (5). If the cause is found, correct it. If no cause is found, check 3).</p> <p>3) Check the LED displays for troubleshooting on other remote controllers whether an error occurs.</p> <p>If an error is found, -> If an error is found, check the check code definition, and correct the error. If no error is found, -> Indoor unit board failure</p>

1. Error Code

6607

No ACK error

2. Error definition and error detection method

The error is detected when no acknowledgement (ACK signal) is received after the transmission. (eg. When the data is transmitted six times in a row with 30 seconds interval, the error is detected on the transmission side.)

Note

The address/attribute appeared on the display on the remote controller indicates the controller which did not provide the response (ACK).

3. System configuration

(2) Grouping of units in a system with multiple heat source units

Error source address	Error display	Detection method	Cause	Check method and remedy
LOSS-NAY (LC)	ME remote controller (RC) MA remote controller (MA)	No acknowledgement (ACK) at IC transmission to LC	<p>(1) Factors (1) through (5) in the "Factors in system with one heat source unit" (When performing an interlocked operation of the LOSSNAY unit and the indoor units that are connected to different heat source units.)</p> <p>(2) Disconnection or short circuit of the transmission line for the heat source unit on the terminal block for centralized control line connection (TB7)</p> <p>(3) When multiple heat source units are connected and the power source of one of the heat source units has been shut off.</p> <p>(4) The male power supply connector of the heat source unit is not connected to the female power supply switch connector (CN40).</p> <p>(5) The male power supply connectors on 2 or more heat source units are connected to the female power supply switch connector (CN40) for centralized control.</p> <p>If an error occurs, after the unit runs normally once, the following causes may be considered.</p> <ul style="list-style-type: none"> ◆Total capacity error (7100) ◆Capacity code error (7101) ◆Error in the number of connected units (7102) ◆Address setting error (7105) 	<p>1) Turn off the power source of heat source unit for 5 or more minutes, and turn it on again. If the error is accidental, it will run normally. If not, check the cause 2).</p> <p>2) Check the causes of (1) - (5). If the cause is found, correct it. If no cause is found, check 3).</p> <p>3) Same cause as that for indoor unit described in 3)</p>

1. Error Code

6607

No ACK error

2. Error definition and error detection method

The error is detected when no acknowledgement (ACK signal) is received after the transmission. (eg. When the data is transmitted six times in a row with 30 seconds interval, the error is detected on the transmission side.)

Note

The address/attribute appeared on the display on the remote controller indicates the controller which did not provide the response (ACK).

3. System configuration

(2) Grouping of units in a system with multiple heat source units

Error source address	Error display	Detection method	Cause	Check method and remedy
ME remote controller (RC)	ME remote controller (RC) MA remote controller (MA)	No acknowledgement (ACK) at IC transmission to RC	(1) Same causes as (1) - (4) for system with one heat source unit (2) Disconnection or short circuit of the transmission line for the heat source unit on the terminal block for centralized control line connection (TB7) (3) When multiple heat source units are connected and the power source of one of the heat source units has been shut off. (4) The male power supply connector of the heat source unit is not connected to the female power supply switch connector (CN40). (5) The male power supply connectors on 2 or more heat source units are connected to the female power supply switch connector (CN40) for centralized control. If the problem recurs after normal operation is restored, the problem is caused by one of the following factors: ♦Total capacity error (7100) ♦Capacity code setting error (7101) ♦Error in the number of connected units (7102) ♦Address setting error (7105)	1) Turn off the power source of heat source unit for 5 or more minutes, and turn it on again. If the error is accidental, it will run normally. If not, check the cause 2). 2) Check the causes of (1) - (5). If the cause is found, correct it. If no cause is found, check 3). 3) Same cause as that for indoor unit described in 3)

1. Error Code

6607

No ACK error

2. Error definition and error detection method

The error is detected when no acknowledgement (ACK signal) is received after the transmission. (eg. When the data is transmitted six times in a row with 30 seconds interval, the error is detected on the transmission side.)

Note

The address/attribute appeared on the display on the remote controller indicates the controller which did not provide the response (ACK).

3. System configuration

(3) System connected to the system controllers (MELANS)

Error source address	Error display	Detection method	Cause	Check method and remedy
Heat source unit (OC)	ME remote controller (RC) System controller (SC) MA remote controller (MA)	No acknowledgement (ACK) at IC transmission to OC	Same cause as that for system with one heat source unit	Same remedy as that for system with one heat source unit
BC controller (BC)	ME remote controller (RC) system controller (SC) MA remote controller (MA)	No acknowledgement (ACK) at IC transmission to BC	Same cause as that for system with one heat source unit	Same remedy as that for system with one heat source unit

1. Error Code

6607

No ACK error

2. Error definition and error detection method

The error is detected when no acknowledgement (ACK signal) is received after the transmission. (eg. When the data is transmitted six times in a row with 30 seconds interval, the error is detected on the transmission side.)

Note

The address/attribute appeared on the display on the remote controller indicates the controller which did not provide the response (ACK).

3. System configuration

(3) System connected to the system controllers (MELANS)

Error source address	Error display	Detection method	Cause	Check method and remedy
Indoor unit (IC)	ME remote controller (RC) MA remote controller (MA)	No acknowledgement (ACK) at RC transmission to IC	Same as grouping of units in a system with multiple heat source units	Same remedy as that for grouping of units in a system with multiple heat source units
	System controller (SC)	No acknowledgement (ACK) at SC transmission to IC	1. Error occurrence on some IC (1) Same cause as that for system with one heat source unit	Same remedy as that for system with one heat source unit
			2. Error occurrence on all IC in the system with one heat source unit (1) Total capacity error (7100) (2) Capacity code error (7101) (3) Error in the number of connected units (7102) (4) Address setting error (7105) (5) Disconnection or short circuit of the transmission line for the heat source unit on the terminal block for centralized control line connection (TB7) (6) Turn off the power source of the heat source unit (7) Malfunction of electrical system for the heat source unit	1) Check the LED display for troubleshooting on the heat source unit. ♦If an error is found, check the check code definition, and correct the error. ♦If no error is found, check 2). 2) Check (5) - (7) on the left.
		3. Error occurrence on all IC (1) Same causes as (1) - (7) described in 2. (2) The male power supply connectors on 2 or more heat source units are connected to the female power supply switch connector (CN40) for the transmission line for centralized control. (3) Disconnection or shutdown of the power source of the power supply unit for transmission line (4) System controller (MELANS) malfunction	Check voltage of the transmission line for centralized control. ♦20V or more: Check (1) and (2) on the left. ♦Less than 20V: Check (3) on the left.	

1. Error Code

6607

No ACK error

2. Error definition and error detection method

The error is detected when no acknowledgement (ACK signal) is received after the transmission. (eg. When the data is transmitted six times in a row with 30 seconds interval, the error is detected on the transmission side.)

Note

The address/attribute appeared on the display on the remote controller indicates the controller which did not provide the response (ACK).

3. System configuration

(3) System connected to the system controllers (MELANS)

Error source address	Error display	Detection method	Cause	Check method and remedy
ME remote controller (RC)	ME remote controller (RC) System controller (SC) MA remote controller (MA)	No acknowledgement (ACK) at IC transmission to RC	Same as grouping of units in a system with multiple heat source units	Same remedy as that for grouping of units in a system with multiple heat source units
	System controller (SC)	No acknowledgement (ACK) at MELANS transmission to RC	1. Error occurrence on some IC (1) Same cause as that for system with one heat source unit	Same remedy as that for system with one heat source unit
			2. Error occurrence on all IC in the system with one heat source unit (1) An error is found by the heat source unit. Total capacity error (7100) Capacity code error (7101) Error in the number of connected units (7102) Address setting error (7105) (2) Disconnection or short circuit of the transmission line for the heat source unit on the terminal block for centralized control line connection (TB7) (3) Turn off the power source of the heat source unit (4) Malfunction of electrical system for the heat source unit	1) Check the LED display for troubleshooting on the heat source unit. ♦ If an error is found, check the check code definition, and correct the error. ♦ If no error is found, check the cause 2). 2) Check (2) - (4) on the left.
		3. Error occurrence on all IC (1) Same causes as (1) - (4) described in 2. (2) When the power supply unit for transmission lines is used and the male power supply connector is connected to the female power supply switch connector (CN40) for the transmission line for centralized control (3) Disconnection or shutdown of the power source of the power supply unit for transmission line (4) System controller (MELANS) malfunction	Check (1) - (4) on the left.	

1. Error Code

6607

No ACK error

2. Error definition and error detection method

The error is detected when no acknowledgement (ACK signal) is received after the transmission. (eg. When the data is transmitted six times in a row with 30 seconds interval, the error is detected on the transmission side.)

Note

The address/attribute appeared on the display on the remote controller indicates the controller which did not provide the response (ACK).

3. System configuration

(3) System connected to the system controllers (MELANS)

Error source address	Error display	Detection method	Cause	Check method and remedy
System controller (SC)	ME remote controller (RC) MA remote controller (MA)	No acknowledgement (ACK) at IC transmission to SC	1. Error display on some displays on ME remote controllers	Check (1) - (3) on the left.
			(1) Faulty wiring of the transmission line for ME remote controller	
			(2) Disconnection or contact failure of the transmission connector for ME remote controller	
			(3) ME remote controller failure	
			2. Error occurrence on all IC in the system with one heat source unit	1) Check the LED display for troubleshooting on the heat source unit.
			(1) An error is found by the heat source unit. Total capacity error (7100) Capacity code error (7101) Error in the number of connected units (7102) Address setting error (7105)	♦ If an error is found, check the check code definition, and correct the error. ♦ If no error is found, check the cause 2)
			(2) Disconnection or short circuit of the transmission line for the heat source unit on the terminal block for centralized control line connection (TB7)	2) Check (2) - (4) on the left.
			(3) Turn off the power source of the heat source unit	
			(4) Malfunction of electrical system for the heat source unit	
			3. Error display on all displays on ME remote controllers	Check (1) - (4) on the left
			(1) Same causes as (1) - (4) described in 2.	
			(2) When the power supply unit for transmission lines is used and the male power supply connector is connected to the female power supply switch connector (CN40) for the transmission line for centralized control	
			(3) Disconnection or shutdown of the power source of the power supply unit for transmission line	
			(4) System controller (MELANS) malfunction	

1. Error Code

6607

No ACK error

2. Error definition and error detection method

The error is detected when no acknowledgement (ACK signal) is received after the transmission. (eg. When the data is transmitted six times in a row with 30 seconds interval, the error is detected on the transmission side.)

Note

The address/attribute appeared on the display on the remote controller indicates the controller which did not provide the response (ACK).

3. System configuration

(4) Errors that are not limited to a particular system

Error source address	Error display	Detection method	Cause	Check method and remedy
Address which should not be existed	-	-	<p>(1) Although the address of ME remote controller has been changed after the group is set using ME remote controller, the indoor unit is keeping the memory of the previous address. The same symptom will appear for the registration with SC.</p> <p>(2) Although the address of LOSSNAY has been changed after the interlock registration of LOSSNAY is made using ME remote controller, the indoor unit is keeping the memory of the previous address.</p>	<p>Delete unnecessary information of non-existing address which some indoor units have. Use either of the following two methods for deletion.</p> <p>1) Address deletion by ME remote controller Delete unnecessary address information using the manual setting function of ME remote controller. Refer to this service handbook "IV [2] Group Settings and Interlock Settings via the ME Remote Controller 1. (3) Address deletion."</p> <p>2) Deletion of connection information of the heat source unit by the deleting switch</p> <p>Note that this switch deletes all the group information set via ME remote controller and all the interlock information of LOSSNAY and the indoor unit.</p> <ul style="list-style-type: none"> ♦ Turn off the power source of the heat source unit, and wait for 5 minutes. ♦ Turn on the dip switch (SW5-2) on the heat source unit control board. ♦ Turn on the power source of the heat source unit, and wait for 5 minutes. ♦ Turn off the power source of the heat source unit, and wait for 5 minutes. ♦ Turn on the power source of the heat source unit.

1. Error Code

6608

No response error

2. Error definition and error detection method

- ♦When no response command is returned although acknowledgement (ACK) is received after transmission, an error is detected.
- ♦When the data is transmitted 10 times in a row with 3 seconds interval, an error is detected on the transmission side.

Note

The address/attribute appeared on the display on the remote controller indicates the controller where an error occurred.

3. Cause

- 1) The transmission line work is performed while the power is on, the transmitted data will collide, and the wave shape will be changed.
- 2) The transmission is sent and received repeatedly due to noise.
- 3) Decrease of transmission line voltage/signal by exceeding acceptable range of transmission wiring.
Farthest:200m [656ft] or less
Remote controller wiring:12m [39ft] or less
- 4) The transmission line voltage/signal is decreased due to erroneous sizing of transmission line.
Wire diameter: 1.25mm²[AWG16] or more

4. Check method and remedy

- 1) When an error occurs during commissioning, turn off the power sources for the heat source unit, indoor unit, BC controller, and LOSSNAY for 5 or more minutes, and then turn them on again.
 - ♦ When they return to normal operation, the cause of the error is the transmission line work performed with the power on.
 - ♦ If an error occurs again, check the cause 2).
- 2) Check 3) and 4) above.
 - ♦ If the cause is found, correct it.
 - ♦ If no cause is found, check 3).
- 3) Check transmission wave shape/ noise on trans-mission line by following "IX [3] Investigation of Transmission Wave Shape/ Noise" .

Noise is the most possible cause of the error "6608".

1. Error Code

6831

MA controller signal reception error (No signal reception)

2. Error definition and error detection method

- Communication between the MA remote controller and the indoor unit is not done properly.
- No proper data has been received for 3 minutes.

3. Cause

- 1) Contact failure of the remote controller lines of MA remote controller or the indoor unit.
- 2) All the remote controllers are set to SUB.
- 3) Failure to meet wiring regulations
 - Wire length
 - Wire size
 - Number of remote controllers
 - Number of indoor units
- 4) The remote controller is removed after the installation without turning the power source off.
- 5) Noise interference on the remote controller transmission lines
- 6) Faulty circuit that is on the indoor board and performs transmission/ reception of the signal from the remote controller
- 7) Problems with the circuit on the remote controller that sends or receives the signals from the remote controller

4. Check method and remedy

- 1) Check for disconnected or loose transmission lines for the indoor units or MA remote controllers.
- 2) Confirm that the power is supplied to the main power source and the remote controller line.
- 3) Confirm that MA remote controller's capacity limit is not exceeded.
- 4) Check the sub/main setting of the MA remote controllers. One of them must be set to MAIN.
- 5) Diagnose the remote controller (described in the remote controller installation manual).
[OK]: no problems with the remote controller (check the wiring regulations)
[NG]: Replace the MA remote controller.
[6832, 6833, ERC]: Due to noise interference <Go to 6>
- 6) Check wave shape/noise on MA remote controller line by following "IX [3] Investigation of Transmission Wave Shape/Noise".
- 7) When no problems are found with items 1) through 6), replace the indoor unit board or the MA remote controller.
The following status can be confirmed on LED1 and 2 on the indoor unit board.
 - If LED1 is lit, the main power source of the indoor unit is turned on.
 - If LED2 is lit, the MA remote controller line is being powered.

1. Error Code

6832

MA remote controller signal transmission error (Synchronization error)

2. Error definition and error detection method

- ♦MA remote controller and the indoor unit is not done properly.
- ♦Failure to detect opening in the transmission path and unable to send signals
 - *Indoor unit : 3 minutes
 - *Remote controller : 6 seconds

3. Cause

- 1) Contact failure of the remote controller lines of MA remote controller or the indoor unit
- 2) 2 or more remote controllers are set to MAIN
- 3) Overlapped indoor unit address
- 4) Noise interference on the remote controller lines
- 5) Failure to meet wiring regulations
 - ♦Wire length
 - ♦Wire size
 - ♦Number of remote controllers
 - ♦Number of indoor units
- 6) Problems with the circuit on the remote controller that sends or receives the signals from the remote controller

4. Check method and remedy

- 1) Check for disconnected or loose transmission lines for the indoor units or MA remote controllers.
- 2) Confirm that the power is supplied to the main power source and the remote controller line.
- 3) Confirm that MA remote controller's capacity limit is not exceeded.
- 4) Check the sub/main setting of the MA remote controllers. One of them must be set to MAIN.
- 5) Diagnose the remote controller (described in the remote controller installation manual).
 - [OK]: no problems with the remote controller (check the wiring regulations)
 - [NG]: Replace the MA remote controller.
 - [6832, 6833, ERC]: Due to noise interference <Go to 6>
- 6) Check wave shape/noise on MA remote controller line by following "IX [3] Investigation of Transmission Wave Shape/Noise".
- 7) When no problems are found with items 1) through 6), replace the indoor unit board or the MA remote controller.
 - The following status can be confirmed on LED1 and 2 on the indoor unit board.
 - ♦If LED1 is lit, the main power source of the indoor unit is turned on.
 - ♦If LED2 is lit, the MA remote controller line is being powered.

1. Error Code

6833

MA remote controller signal transmission error (Hardware error)

2. Error definition and error detection method

- Communication between the MA remote controller and the indoor unit is not done properly.
- An error occurs when the transmitted data and the received data differ for 30 times in a row.

3. Cause

- 1) Contact failure of the remote controller lines of MA remote controller or the indoor unit
- 2) 2 or more remote controllers are set to MAIN
- 3) Overlapped indoor unit address
- 4) Noise interference on the remote controller lines
- 5) Failure to meet wiring regulations
 - Wire length
 - Wire size
 - Number of remote controllers
 - Number of indoor units
- 6) Problems with the circuit on the remote controller that sends or receives the signals from the remote controller

4. Check method and remedy

- 1) Check for disconnected or loose transmission lines for the indoor units or MA remote controllers.
- 2) Confirm that the power is supplied to the main power source and the remote controller line.
- 3) Confirm that MA remote controller's capacity limit is not exceeded.
- 4) Check the sub/main setting of the MA remote controllers. One of them must be set to MAIN.
- 5) Diagnose the remote controller (described in the remote controller installation manual).
 - [OK]: no problems with the remote controller (check the wiring regulations)
 - [NG]: Replace the MA remote controller.
 - [6832, 6833, ERC]: Due to noise interference <Go to 6>
- 6) Check wave shape/noise on MA remote controller line by following "IX [3] Investigation of Transmission Wave Shape/Noise".
- 7) When no problems are found with items 1) through 6), replace the indoor unit board or the MA remote controller.
 - The following status can be confirmed on LED1 and 2 on the indoor unit board.
 - If LED1 is lit, the main power source of the indoor unit is turned on.
 - If LED2 is lit, the MA remote controller line is being powered.

1. Error Code

6834

MA controller signal reception error (Start bit detection error)

2. Error definition and error detection method

- Communication between the MA remote controller and the indoor unit is not done properly.
- No proper data has been received for 2 minutes.

3. Cause

- 1) Contact failure of the remote controller lines of MA remote controller or the indoor unit.
- 2) All the remote controllers are set to SUB.
- 3) Failure to meet wiring regulations
 - Wire length
 - Wire size
 - Number of remote controllers
 - Number of indoor units
- 4) The remote controller is removed after the installation without turning the power source off.
- 5) Noise interference on the remote controller transmission lines
- 6) Faulty circuit that is on the indoor board and performs transmission/ reception of the signal from the remote controller
- 7) Problems with the circuit on the remote controller that sends or receives the signals from the remote controller

4. Check method and remedy

- 1) Check for disconnected or loose transmission lines for the indoor units or MA remote controllers.
- 2) Confirm that the power is supplied to the main power source and the remote controller line.
- 3) Confirm that MA remote controller's capacity limit is not exceeded.
- 4) Check the sub/main setting of the MA remote controllers. One of them must be set to MAIN.
- 5) Diagnose the remote controller (described in the remote controller installation manual).
[OK]: no problems with the remote controller (check the wiring regulations)
[NG]: Replace the MA remote controller.
[6832, 6833, ERC]: Due to noise interference <Go to 6>
- 6) Check wave shape/noise on MA remote controller line by following "IX [3] Investigation of Transmission Wave Shape/Noise".
- 7) When no problems are found with items 1) through 6), replace the indoor unit board or the MA remote controller.
The following status can be confirmed on LED1 and 2 on the indoor unit board.
 - If LED1 is lit, the main power source of the indoor unit is turned on
 - If LED2 is lit, the MA remote controller line is being powered.

1. Error Code

7100

Total capacity error

2. Error definition and error detection method

The model total of indoor units in the system with one heat source unit exceeds limitations.

3. Error source, cause, check method and remedy,

Error source	Cause	Check method and remedy																																																						
Heat source unit	<p>(1) The model total of indoor units in the system with one heat source unit exceeds the following table.</p> <p style="text-align: center;"><PQHY></p> <table border="1" style="margin-left: auto; margin-right: auto; border-collapse: collapse;"> <thead> <tr> <th style="width: 50%;">Model</th> <th style="width: 50%;">Capacity Total</th> </tr> </thead> <tbody> <tr><td>P72 model</td><td>93</td></tr> <tr><td>P96 model</td><td>124</td></tr> <tr><td>P120 model</td><td>156</td></tr> <tr><td>P144 model</td><td>187</td></tr> <tr><td>P168 model</td><td>218</td></tr> <tr><td>P192 model</td><td>249</td></tr> <tr><td>P216 model</td><td>280</td></tr> <tr><td>P240 model</td><td>312</td></tr> <tr><td>P264 model</td><td>343</td></tr> <tr><td>P288 model</td><td>374</td></tr> <tr><td>P312 model</td><td>405</td></tr> <tr><td>P336 model</td><td>436</td></tr> <tr><td>P360 model</td><td>468</td></tr> </tbody> </table> <p style="text-align: center;"><PQRY></p> <table border="1" style="margin-left: auto; margin-right: auto; border-collapse: collapse;"> <thead> <tr> <th style="width: 50%;">Model</th> <th style="width: 50%;">Capacity Total</th> </tr> </thead> <tbody> <tr><td>P72 model</td><td>108</td></tr> <tr><td>P96 model</td><td>144</td></tr> <tr><td>P120 model</td><td>180</td></tr> <tr><td>P144 model</td><td>216</td></tr> <tr><td>P168 model</td><td>252</td></tr> <tr><td>P192 model</td><td>288</td></tr> <tr><td>P216 model</td><td>324</td></tr> <tr><td>P240 model</td><td>360</td></tr> <tr><td>P264 model</td><td>396</td></tr> <tr><td>P288 model</td><td>432</td></tr> <tr><td>P312 model</td><td>468</td></tr> <tr><td>P336 model</td><td>504</td></tr> </tbody> </table>	Model	Capacity Total	P72 model	93	P96 model	124	P120 model	156	P144 model	187	P168 model	218	P192 model	249	P216 model	280	P240 model	312	P264 model	343	P288 model	374	P312 model	405	P336 model	436	P360 model	468	Model	Capacity Total	P72 model	108	P96 model	144	P120 model	180	P144 model	216	P168 model	252	P192 model	288	P216 model	324	P240 model	360	P264 model	396	P288 model	432	P312 model	468	P336 model	504	<p>1) Check the model total (capacity code total) of units connected.</p> <p>2) Check the model name (capacity code) of the connected indoor unit set by the switch (SW2 on indoor unit board).</p> <p>When the model name set by the switch is different from that of the unit connected, turn off the power source of the heat source and the indoor units, and change the setting of the model name (capacity code).</p>
	Model	Capacity Total																																																						
	P72 model	93																																																						
P96 model	124																																																							
P120 model	156																																																							
P144 model	187																																																							
P168 model	218																																																							
P192 model	249																																																							
P216 model	280																																																							
P240 model	312																																																							
P264 model	343																																																							
P288 model	374																																																							
P312 model	405																																																							
P336 model	436																																																							
P360 model	468																																																							
Model	Capacity Total																																																							
P72 model	108																																																							
P96 model	144																																																							
P120 model	180																																																							
P144 model	216																																																							
P168 model	252																																																							
P192 model	288																																																							
P216 model	324																																																							
P240 model	360																																																							
P264 model	396																																																							
P288 model	432																																																							
P312 model	468																																																							
P336 model	504																																																							
	<p>(2) The model selection switches (SW5-3 - 5-6) on the heat source unit are set incorrectly.</p> <table border="1" style="margin-left: auto; margin-right: auto; border-collapse: collapse;"> <thead> <tr> <th rowspan="2" style="width: 20%;">Model</th> <th colspan="4" style="width: 80%;">SW5</th> </tr> <tr> <th style="width: 10%;">3</th> <th style="width: 10%;">4</th> <th style="width: 10%;">5</th> <th style="width: 10%;">6</th> </tr> </thead> <tbody> <tr><td>72 model</td><td>OFF</td><td>ON</td><td>OFF</td><td>OFF</td></tr> <tr><td>96 model</td><td>ON</td><td>ON</td><td>OFF</td><td>OFF</td></tr> <tr><td>120 model</td><td>OFF</td><td>OFF</td><td>ON</td><td>OFF</td></tr> <tr><td>144 model</td><td>ON</td><td>ON</td><td>ON</td><td>OFF</td></tr> <tr><td>168 model</td><td>OFF</td><td>OFF</td><td>OFF</td><td>ON</td></tr> <tr><td>192 model</td><td>ON</td><td>OFF</td><td>OFF</td><td>ON</td></tr> <tr><td>216 model</td><td>OFF</td><td>ON</td><td>OFF</td><td>ON</td></tr> <tr><td>240 model</td><td>ON</td><td>ON</td><td>OFF</td><td>ON</td></tr> </tbody> </table>	Model	SW5				3	4	5	6	72 model	OFF	ON	OFF	OFF	96 model	ON	ON	OFF	OFF	120 model	OFF	OFF	ON	OFF	144 model	ON	ON	ON	OFF	168 model	OFF	OFF	OFF	ON	192 model	ON	OFF	OFF	ON	216 model	OFF	ON	OFF	ON	240 model	ON	ON	OFF	ON	<p>Check the setting for the model selection switch on the heat source unit (Dipswitches SW5-3 - 5-6 on the heat source unit control board).</p>					
Model	SW5																																																							
	3	4	5	6																																																				
72 model	OFF	ON	OFF	OFF																																																				
96 model	ON	ON	OFF	OFF																																																				
120 model	OFF	OFF	ON	OFF																																																				
144 model	ON	ON	ON	OFF																																																				
168 model	OFF	OFF	OFF	ON																																																				
192 model	ON	OFF	OFF	ON																																																				
216 model	OFF	ON	OFF	ON																																																				
240 model	ON	ON	OFF	ON																																																				
	<p>(3) The heat source unit and the auxiliary unit (OS) that is connected to the same system are not properly connected.</p>	<p>Confirm that the TB3 on the OC and OS are properly connected.</p>																																																						

1. Error Code

7101

Capacity code setting error

2. Error definition and error detection method

Connection of incompatible (wrong capacity code) indoor unit or heat source unit

3. Error source, cause, check method and remedy

Error source	Cause	Check method and remedy																																																	
Heat source unit Indoor unit	(1) The model name (capacity code) set by the switch (SW2) is wrong. *The capacity of the indoor unit can be confirmed by the self-diagnosis function (SW4 operation(SW6-10: OFF)) of the heat source unit.	1) Check the model name (capacity code) of the indoor unit which has the error source address set by the switch (SW2 on indoor unit board). When the model name set by the switch is different from that of the unit connected, turn off the power source of the heat source and the indoor units, and change the setting of the capacity code.																																																	
Heat source unit	(2) The model selection switches (SW5-3 - 5-6) on the heat source unit are set incorrectly. <table border="1" data-bbox="492 787 824 1115" style="margin-left: auto; margin-right: auto;"> <thead> <tr> <th rowspan="2">Model</th> <th colspan="4">SW5</th> </tr> <tr> <th>3</th> <th>4</th> <th>5</th> <th>6</th> </tr> </thead> <tbody> <tr> <td>72 model</td> <td>OFF</td> <td>ON</td> <td>OFF</td> <td>OFF</td> </tr> <tr> <td>96 model</td> <td>ON</td> <td>ON</td> <td>OFF</td> <td>OFF</td> </tr> <tr> <td>120 model</td> <td>OFF</td> <td>OFF</td> <td>ON</td> <td>OFF</td> </tr> <tr> <td>144 model</td> <td>ON</td> <td>ON</td> <td>ON</td> <td>OFF</td> </tr> <tr> <td>168 model</td> <td>OFF</td> <td>OFF</td> <td>OFF</td> <td>ON</td> </tr> <tr> <td>192 model</td> <td>ON</td> <td>OFF</td> <td>OFF</td> <td>ON</td> </tr> <tr> <td>216 model</td> <td>OFF</td> <td>ON</td> <td>OFF</td> <td>ON</td> </tr> <tr> <td>240 model</td> <td>ON</td> <td>ON</td> <td>OFF</td> <td>ON</td> </tr> </tbody> </table>	Model	SW5				3	4	5	6	72 model	OFF	ON	OFF	OFF	96 model	ON	ON	OFF	OFF	120 model	OFF	OFF	ON	OFF	144 model	ON	ON	ON	OFF	168 model	OFF	OFF	OFF	ON	192 model	ON	OFF	OFF	ON	216 model	OFF	ON	OFF	ON	240 model	ON	ON	OFF	ON	Check the setting for the model selection switch on the heat source unit (Dipswitches SW5-3 - 5-6 on the heat source unit control board).
Model	SW5																																																		
	3	4	5	6																																															
72 model	OFF	ON	OFF	OFF																																															
96 model	ON	ON	OFF	OFF																																															
120 model	OFF	OFF	ON	OFF																																															
144 model	ON	ON	ON	OFF																																															
168 model	OFF	OFF	OFF	ON																																															
192 model	ON	OFF	OFF	ON																																															
216 model	OFF	ON	OFF	ON																																															
240 model	ON	ON	OFF	ON																																															

1. Error Code

7102

Wrong number of connected units

2. Error definition and error detection method

The number of connected indoor units is "0" or exceeds the allowable value.

3. Error source, cause, check method and remedy

Error source	Cause	Check method and remedy														
Heat source unit	<p>(1) Number of indoor units connected to the heat source terminal block (TB3) for indoor-heat source transmission lines exceeds limitations described below.</p> <table border="1" style="width: 100%; border-collapse: collapse; margin-top: 10px;"> <thead> <tr> <th style="width: 30%;">Number of units</th> <th style="width: 70%;">Restriction on the number of units</th> </tr> </thead> <tbody> <tr> <td>Total number of indoor units</td> <td> <PQHY> 1 - 15 : P72 model 1 - 20 : P96 model 1 - 26 : P120 model 1 - 31 : P144 model 1 - 36 : P168 model 1 - 41 : P192 model 2 - 46 : P216 model 2 - 50 : P240 - P360 models <PQRY> 1 - 18 : P72 model 1 - 24 : P96 model 1 - 30 : P120 model 1 - 36 : P144 model 1 - 42 : P168 model 1 - 48 : P192 model 2 - 50 : P216 - P336 models </td> </tr> <tr> <td>Number of BC controllers</td> <td style="text-align: center;">1 (P72 - P120 models only)</td> </tr> <tr> <td>Number of Main BC controllers</td> <td style="text-align: center;">0 or 1</td> </tr> <tr> <td>Number of Sub BC controllers</td> <td style="text-align: center;">0,1 or 2</td> </tr> <tr> <td>Total number of LOSSNAY units (During auto address start-up only)</td> <td style="text-align: center;">0 or 1</td> </tr> <tr> <td>Total number of heat source units</td> <td> 1 : P72 - P240 models 2 : P144 - P360 models </td> </tr> </tbody> </table> <p>(2) Disconnected transmission line from the heat source unit or BC controller</p> <p>(3) Short-circuited transmission line When (2) and (3) apply, the following display will appear.</p> <ul style="list-style-type: none"> ◆M-NET remote controller Nothing appears on the remote controller because it is not powered. ◆MA remote controller "HO" or "PLEASE WAIT" blinks. <p>(4) The model selection switch (SW5-7) on the heat source unit is set to OFF. (Normally set to ON)</p> <p>(5) Heat source unit address setting error The heat source units in the same refrigerant circuit do not have sequential address numbers.</p> <p>(6) A type-G BC controller is connected to a unit P144 model or above.</p>	Number of units	Restriction on the number of units	Total number of indoor units	<PQHY> 1 - 15 : P72 model 1 - 20 : P96 model 1 - 26 : P120 model 1 - 31 : P144 model 1 - 36 : P168 model 1 - 41 : P192 model 2 - 46 : P216 model 2 - 50 : P240 - P360 models <PQRY> 1 - 18 : P72 model 1 - 24 : P96 model 1 - 30 : P120 model 1 - 36 : P144 model 1 - 42 : P168 model 1 - 48 : P192 model 2 - 50 : P216 - P336 models	Number of BC controllers	1 (P72 - P120 models only)	Number of Main BC controllers	0 or 1	Number of Sub BC controllers	0,1 or 2	Total number of LOSSNAY units (During auto address start-up only)	0 or 1	Total number of heat source units	1 : P72 - P240 models 2 : P144 - P360 models	<p>1) Check whether the number of units connected to the heat source terminal block (TB3) for indoor-heat source transmission lines does not exceed the limitation. (See (1) and (2) on the left.)</p> <p>2) Check (2) - (3) on the left.</p> <p>3) Check whether the transmission line for the terminal block for centralized control (TB7) is not connected to the terminal block for the indoor-heat source transmission line (TB3).</p> <p>4) Check the setting for the model selection switch on the heat source unit (Dipswitches SW5-7 on the heat source unit control board).</p>
Number of units	Restriction on the number of units															
Total number of indoor units	<PQHY> 1 - 15 : P72 model 1 - 20 : P96 model 1 - 26 : P120 model 1 - 31 : P144 model 1 - 36 : P168 model 1 - 41 : P192 model 2 - 46 : P216 model 2 - 50 : P240 - P360 models <PQRY> 1 - 18 : P72 model 1 - 24 : P96 model 1 - 30 : P120 model 1 - 36 : P144 model 1 - 42 : P168 model 1 - 48 : P192 model 2 - 50 : P216 - P336 models															
Number of BC controllers	1 (P72 - P120 models only)															
Number of Main BC controllers	0 or 1															
Number of Sub BC controllers	0,1 or 2															
Total number of LOSSNAY units (During auto address start-up only)	0 or 1															
Total number of heat source units	1 : P72 - P240 models 2 : P144 - P360 models															

1. Error Code

7105

Address setting error

2. Error definition and error detection method

Erroneous setting of OC unit address
 Erroneous setting of BC controller address

3. Cause, check method and remedy

Error source	Cause	Check method and remedy
Heat source unit BC controller	Erroneous setting of OC unit address The address of heat source unit is not being set to 51 - 100. The address of BC controller is not set to 51 - 100.	Check that the heat source unit and BC controller addresses are set to 00 or a number between 51 and 100. If the heat source unit address is out of the valid range, reset the address with the power to the heat source unit turned off. If the BC controller address is out of the valid range, reset the address with the power to both the heat source unit and BC controller turned off.

1. Error Code

7106

Attribute setting error

2. Error definition and error detection method

Error source	Cause	Check method and remedy						
-	A remote controller for use with indoor units, such as the MA remote controller, is connected to the OA processing unit whose attribute is FU.	To operate the OA processing unit directly via a remote controller for use with indoor units, such as the MA remote controller, set the DIP SW 3-1 on the OA processing unit to ON. <table border="1" style="margin-left: auto; margin-right: auto;"> <tr> <td>Operation Method</td> <td>SW3-1</td> </tr> <tr> <td>Interlocked operation with the indoor unit</td> <td>OFF</td> </tr> <tr> <td>Direct operation via the MA remote controller</td> <td>ON</td> </tr> </table>	Operation Method	SW3-1	Interlocked operation with the indoor unit	OFF	Direct operation via the MA remote controller	ON
Operation Method	SW3-1							
Interlocked operation with the indoor unit	OFF							
Direct operation via the MA remote controller	ON							

1. Error Code

7107

Port setting error

2. Error definition and error detection method

The port with wrong number is connected to the indoor unit. The model total connected to the port is greater than the specification.

3. Cause, check method and remedy

Error source	Cause	Check method and remedy						
BC controller	<p>(1) Model total of indoor units per each port or per each port merge is greater than the specification.</p> <table border="1" style="margin: 10px auto; border-collapse: collapse;"> <tr> <td style="padding: 2px;">Total port number</td> <td style="padding: 2px;">Model total</td> </tr> <tr> <td style="padding: 2px;">Single branching</td> <td style="padding: 2px;">54</td> </tr> <tr> <td style="padding: 2px;">2 branches merge</td> <td style="padding: 2px;">96</td> </tr> </table> <p>(2) 4 or more indoor units are connected to the same port.</p> <p>(3) When two ports are used, the port with the smaller number is not connected to the indoor unit.</p> <p>(4) For the address of the BC controller (Sub 1 or 2), 50 is not added to the smallest indoor unit address, which is connected to the BC controller (Sub1 or 2).</p> <p>(5) In the system to which multiple BC controllers are connected, the indoor unit address connected to the BC controller is not set as shown below.</p> <p>(i) The indoor unit address which is connected to the BC controller (main)</p> <p>(ii) The indoor unit address which is connected to the BC controller (Sub1)</p> <p>(iii) The indoor unit address which is connected to the BC controller (Sub2)</p> <p>Address setting (i) < (ii) < (iii) *(ii) and (iii) can be reversed.</p>	Total port number	Model total	Single branching	54	2 branches merge	96	<p>Before resetting the port number using the port number setting switch or the model using the model (capacity code) setting switch, turn off the power of the heat source unit, the BC controller and the indoor unit.</p>
Total port number	Model total							
Single branching	54							
2 branches merge	96							

1. Error Code

7110

Connection information signal transmission/reception error

2. Error definition and error detection method

The given indoor unit is inoperable because it is not properly connected to the heat source unit in the same system.

3. Error source, cause, check method and remedy

Error source	Cause	Check method and remedy
Heat source unit	(1) Power to the transmission booster is cut off.	1) Confirm that the power to the transmission booster is not cut off by the booster being connected to the switch on the indoor unit. (The unit will not function properly unless the transmission booster is turned on.) ->Reset the power to the heat source unit.
	(2) Power resetting of the transmission booster and heat source unit.	
	(3) Wiring failure between OC and OS	2) Confirm that the TB3 on the OC and OS are properly connected. 3) Check the model selection switch on the heat source unit (Dipswitch SW5-7 on the control board.).
	(4) Broken wire between OC and OS.	
	(5) The model selection switch (SW5-7) on the heat source unit is set to OFF. (Normally set to ON)	

1. Error Code

7111

Remote controller sensor fault

2. Error definition and error detection method

This error occurs when the temperature data is not sent although the remote controller sensor is specified.

3. Error source, cause, check method and remedy

Error source	Cause	Check method and remedy
Indoor unit OA processing unit	The remote controller without the temperature sensor (the wireless remote controller or the ME compact remote controller (mounted type)) is used and the remote controller sensor for the indoor unit is specified. (SW1-1 is ON.)	Replace the remote controller with the one with built-in temperature sensor.

1. Error Code

7113

Function setting error (improper connection of CNTYP)

2. Error source, cause, check method and remedy

Error source	Cause	Check method and remedy
Heat source unit	(1) Wiring fault	(Detail code 15)
	(2) Loose connectors, short-circuit, contact failure	1) Check the connector CNTYP5 on the control board for proper connection. 2) Check the connector CNTYP4 on the control board for proper connection.
	(3) Incompatible control board and INV board (replacement with a wrong circuit board)	(Detail code 14) 1) Check the connector CNTYP4 on the control board for proper connection. 2) Check the connector CNTYP5 on the control board for proper connection.
	(4) DIP SW setting error on the control board	3) Check the settings of SW5-3 through SW5-6 on the control board.
		(Detail code 12) 1) Check the connector CNTYP2 on the control board for proper connection. 2) Check the connector CNTYP5 on the control board for proper connection. 3) Check the connector CNTYP4 on the control board for proper connection. 4) Check the settings of SW5-3 through SW5-6 on the control board.
		(Detail code 16) 1) Check the connector CNTYP on the INV board for proper connection. 2) Check the connector CNTYP5 on the control board for proper connection. 3) Check the connector CNTYP4 on the control board for proper connection. 4) Check the settings of SW5-3 through SW5-6 on the control board. 5) Check the wiring between the control board and INV board. (Refer to the section on Error code 0403.)
		(Detail code 0, 1, 5, 6) 1) Check the wiring between the control board and INV board. (Refer to the section on Error code 0403.) 2) Check the settings of SW5-3 through SW5-6 on the control board. 3) Check the connector CNTYP5 on the control board for proper connection. 4) Check the connector CNTYP4 on the control board for proper connection.
		(Detail code Miscellaneous) *If a set-model-name identification error occurs, check the detail code on the unit on which the error occurred. The detail code that appears on other units will be different from the ones shown above.

1. Error Code

7117

Model setting error

2. Error source, cause, check method and remedy

Error source	Cause	Check method and remedy
Heat source unit	(1) Wiring fault	(Detail code 15)
	(2) Loose connectors, short-circuit, contact failure	1) Check the connector CNTYP5 on the control board for proper connection.
		(Detail code 14)
		1) Check the connector CNTYP4 on the control board for proper connection.
		(Detail code 12)
		1) Check the connector CNTYP2 on the control board for proper connection. 2) Check the connector CNTYP5 on the control board for proper connection.
(Detail code 16)	1) Check the connector CNTYP on the INV board for proper connection. 2) Check the connector CNTYP5 on the control board for proper connection. 3) Check the connector CNTYP4 on the control board for proper connection. 4) Check the wiring between the control board and INV board. (Refer to the section on Error code 0403.)	
(Detail code 0, 1, 5, 6)	1) Check the wiring between the control board and INV board. (Refer to the section on Error code 0403.) 2) Check the settings of SW5-3 through SW5-6 on the control board. 3) Check the connector CNTYP5 on the control board for proper connection. 4) Check the connector CNTYP4 on the control board for proper connection.	
(Detail code Miscellaneous)	*If a set-model-name identification error occurs, check the detail code on the unit on which the error occurred. The detail code that appears on other units will be different from the ones shown above.	

1. Error Code

7130

Incompatible unit combination

2. Error definition and error detection method

The check code will appear when the indoor units with different refrigerant systems are connected.

3. Error source, cause, check method and remedy

Error source	Cause	Check method and remedy
Heat source unit	<p>The connected indoor unit or BC controller is exclusively for use with R22 or R407C. An incompatible indoor unit or BC controller is connected.</p> <p>The M-NET connection adapter is connected to the indoor unit system in a system in which the Slim Model (A control) of units are connected to the M-NET.</p>	<p>Check the model names of the connected indoor unit and the BC controller.</p> <p>Check whether the connecting adapter for M-NET is not connected to the indoor unit. (Connect the connecting adapter for M-NET to the heat source unit.)</p>

-1- Troubleshooting according to the remote controller malfunction or the external input error

In the case of MA remote controller

1. Phenomena

Even if the operation button on the remote controller is pressed, the display remains unlit and the unit does not start running. (Power indicator  does not appear on the screen.)

(1) Cause

- 1) The power is not supplied to the indoor unit.
 - ♦The main power of the indoor unit is not on.
 - ♦The connector on the indoor unit board has come off.
 - ♦The fuse on the indoor unit board has melted.
 - ♦Transformer failure and disconnected wire of the indoor unit.
- 2) Incorrect wiring for the MA remote controller
 - ♦Disconnected wire for the MA remote controller or disconnected line to the terminal block.
 - ♦Short-circuited MA remote controller wiring
 - ♦Incorrect wiring of the MA remote controller cables
 - ♦Incorrect connection of the MA remote wiring to the terminal block for transmission line (TB5) on the indoor unit
 - ♦Wiring mixup between the MA remote controller cable and 220 - 240 VAC power supply cable
 - ♦Reversed connection of the wire for the MA remote controller and the M-NET transmission line on the indoor unit
- 3) The number of the MA remote controllers that are connected to an indoor unit exceeds the allowable range (2 units).
- 4) The length or the diameter of the wire for the MA remote controller are out of specification.
- 5) Short circuit of the wire for the remote display output of the heat source unit or reversed polarity connection of the relay.
- 6) The indoor unit board failure
- 7) MA remote controller failure

(2) Check method and remedy

- 1) Measure voltages of the MA remote controller terminal (among 1 to 3).
 - ♦If the voltage is between DC 9 and 12V, the remote controller is a failure.
 - ♦If no voltage is applied, check the causes 1) and 3) and if the cause is found, correct it.
 - If no cause is found, refer to 2).
- 2) Remove the wire for the remote controller from the terminal block (TB13) on the MA remote controller for the indoor unit, and check voltage among 1 to 3.
 - ♦If the voltage is between DC 9 and 12 V, check the causes 2) and 4) and if the cause is found, correct it.
 - ♦If no voltage is applied, check the cause 1) and if the cause is found, correct it.
 - If no cause is found, check the wire for the remote display output (relay polarity).
 - If no further cause is found, replace the indoor unit board.

In the case of MA remote controller

2. Phenomena

When the remote controller operation SW is turned on, the operation status briefly appears on the display, then it goes off, and the display lights out immediately, and the unit stops.

(1) Cause

- 1) The power for the M-NET transmission line is not supplied from the heat source unit.
- 2) Short circuit of the transmission line.
- 3) Incorrect wiring of the M-NET transmission line on the heat source unit.
 - Disconnected wire for the MA remote controller or disconnected line to the terminal block.
 - The indoor transmission line is connected incorrectly to the transmission terminal block for centralized controller (TB7).
 - The male power supply connectors on the multiple heat source units are connected to the female power supply switch connector (CN40).

In the system to which the power supply unit for transmission lines is connected, the male power supply connector is connected to the female power supply switch connector (CN40) on the heat source unit.
- 4) Disconnected M-NET transmission line on the indoor unit side.
- 5) Disconnected wire between the terminal block for M-NET line (TB5) of the indoor unit and the indoor unit board (CN2M) or disconnected connector.

(2) Check method and remedy

- 1) **When 2) and 3) above apply, check code 7102 will be displayed on the self-diagnosis LED on the heat source unit.**

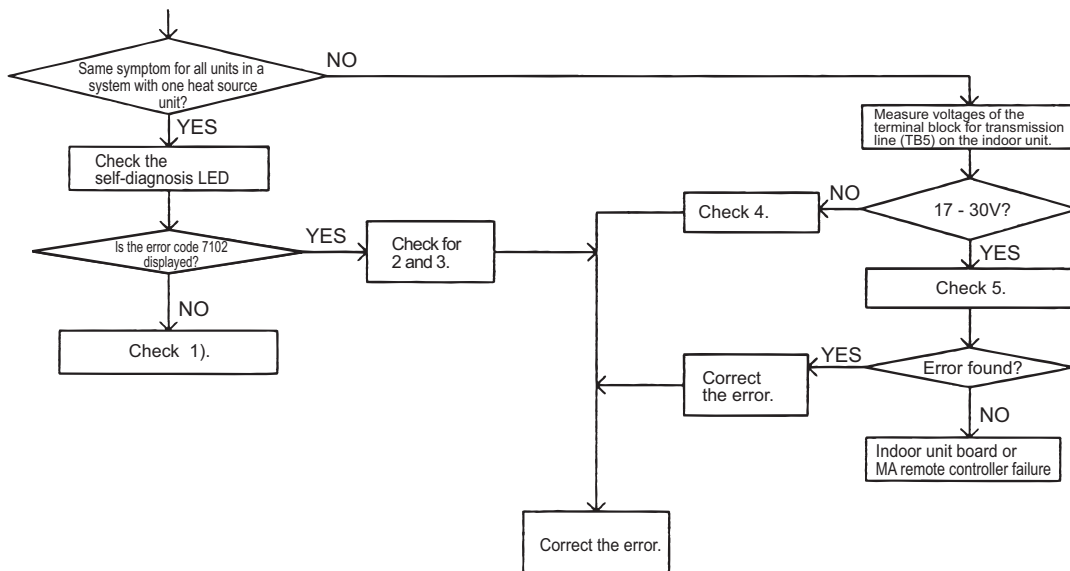

Refer to IX [4] -7- (2) "Troubleshooting transmission power circuit of heat source unit" for how to check item 1 in the flow chart above.

In the case of MA remote controller

3. Phenomena

"HO" or "PLEASE WAIT" display on the remote controller does not disappear, and no operation is performed even if the button is pressed. ("HO" or "PLEASE WAIT" display will normally turn off 5 minutes later after the power on.)

(1) Cause

- 1) The power for the M-NET transmission line is not supplied from the heat source unit.
- 2) Short-circuited transmission line
- 3) Incorrect wiring of the M-NET transmission line on the heat source unit.
 - ♦ Disconnected wire for the MA remote controller or disconnected line to the terminal block.
 - ♦ The indoor transmission line is connected incorrectly to the transmission terminal block for centralized controller (TB7).
 - ♦ The male power supply connectors on the multiple heat source units are connected to the female power supply switch connector (CN40).

In the system to which the power supply unit for transmission lines is connected, the male power supply connector is connected to the female power supply switch connector (CN40) on the heat source unit
- 4) Disconnected M-NET transmission line on the indoor unit.
- 5) Disconnected wire between the terminal block for M-NET line (TB5) of the indoor unit and the indoor unit board (CN2M) or disconnected connector.
- 6) Incorrect wiring for the MA remote controller
 - ♦ Short-circuited wire for the MA remote controller
 - ♦ Disconnected wire for the MA remote controller (No.2) and disconnected line to the terminal block.
 - ♦ Reversed daisy-chain connection between groups
 - ♦ Incorrect wiring for the MA remote controller to the terminal block for transmission line connection (TB5) on the indoor unit
 - ♦ The M-NET transmission line is connected incorrectly to the terminal block (TB13) for the MA remote controller.
- 7) The sub/main setting of the MA remote controller is set to sub.
- 8) 2 or more main MA remote controllers are connected.
- 9) Indoor unit board failure (MA remote controller communication circuit)
- 10) Remote controller failure
- 11) Heat source unit failure (Refer to IX [9] Troubleshooting Using the Heat source Unit LED Error Display.)

(2) Check method and remedy

- 1) When 2) and 3) above apply, check code 7102 will be displayed on the self-diagnosis LED on the heat source unit.

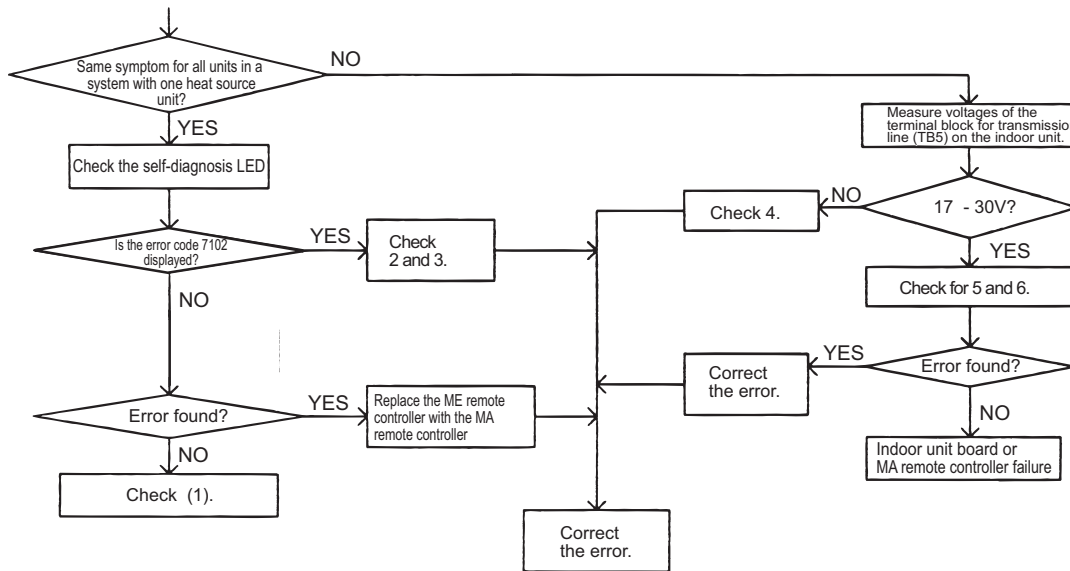

Refer to IX [4] -7- (2) "Troubleshooting transmission power circuit of heat source unit" for how to check item 1 in the flow chart above.

Flow chart

Even if the operation button on the remote controller is pressed, the indoor and the heat source units do not start running.

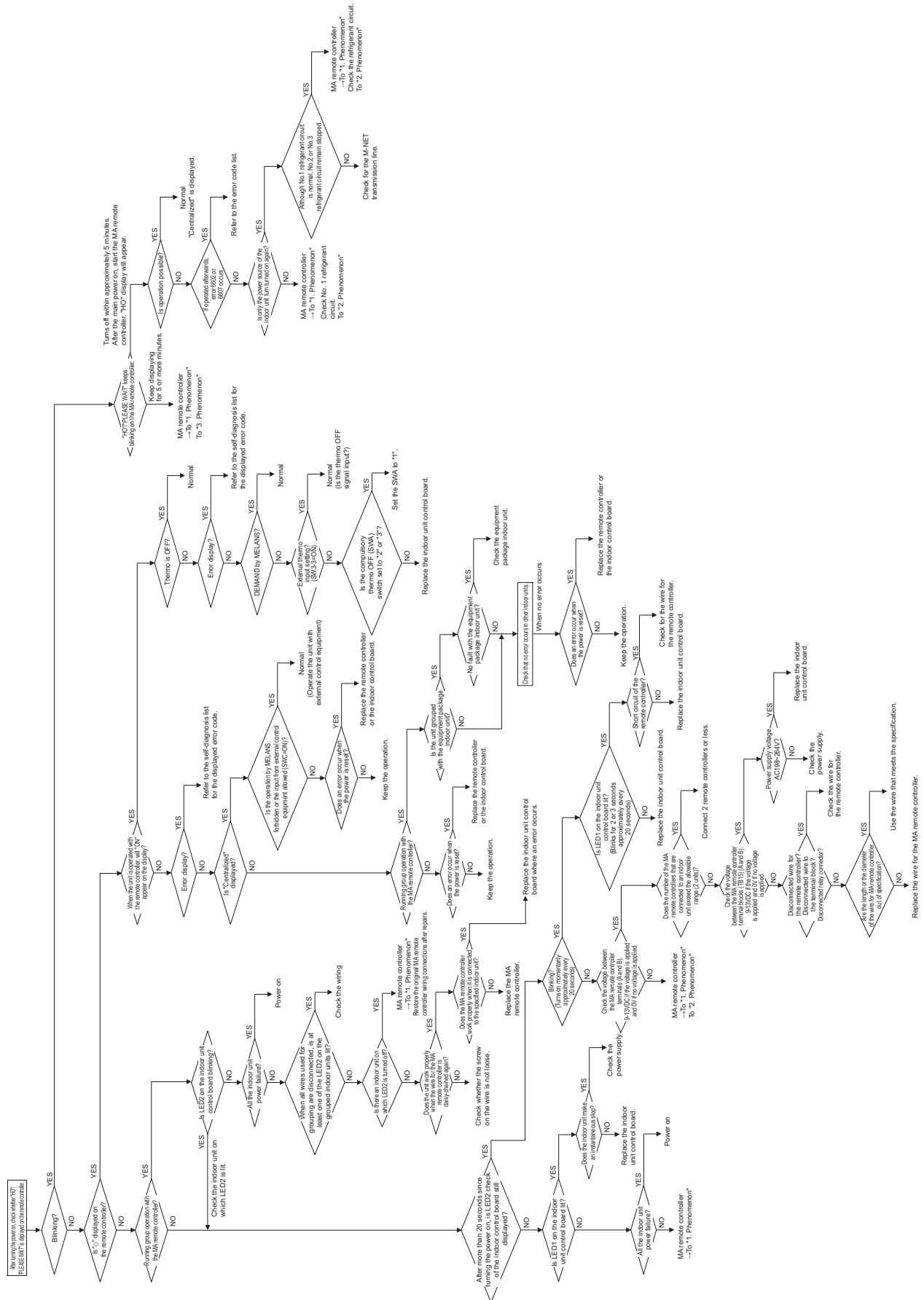

In case of ME remote controller

1. Phenomena

Even if the operation button on the remote controller is pressed, the display remains unlit and the unit does not start running. (Power indicator ● does not appear on the screen.)

(1) Cause

- 1) The power for the M-NET transmission line is not supplied from the indoor unit.
- 2) Short circuit of the transmission line.
- 3) Incorrect wiring of the M-NET transmission line on the heat source unit.
 - Disconnected wire for the MA remote controller or disconnected line to the terminal block.
 - The indoor transmission line is connected incorrectly to the transmission terminal block for centralized controller (TB7).
- 4) Disconnected transmission line on the remote controller.
- 5) Remote controller failure
- 6) Heat source unit failure (Refer to IX [9] Troubleshooting Using the Heat source Unit LED Error Display.)

(2) Check method and remedy

- 1) Check voltage of the transmission terminal block for of the ME remote controller.
 - If voltage between is 17V and 30V -> ME remote controller failure
 - When voltage is 17V or less -> Refer to IX [4] -7- (2) "Troubleshooting transmission power circuit of heat source unit".
- 2) **When 2) and 3) above apply, check code 7102 will be displayed on the self-diagnosis LED on the heat source unit.**

In case of ME remote controller

2. Phenomena

When the remote controller operation SW is turned on, a temporary operation display is indicated, and the display lights out immediately.

(1) Cause

1) The power is not supplied to the indoor unit.

- ♦The main power of the indoor unit (AC208/230V) is not on.
- ♦The connector on the indoor unit board has come off.
- ♦The fuse on the indoor unit board has melted.
- ♦Transformer failure and disconnected wire of the indoor unit
- ♦The indoor unit board failure

2) The heat source control board failure

As the indoor unit does not interact with the heat source unit, the heat source unit model cannot be recognized.

(2) Check method and remedy

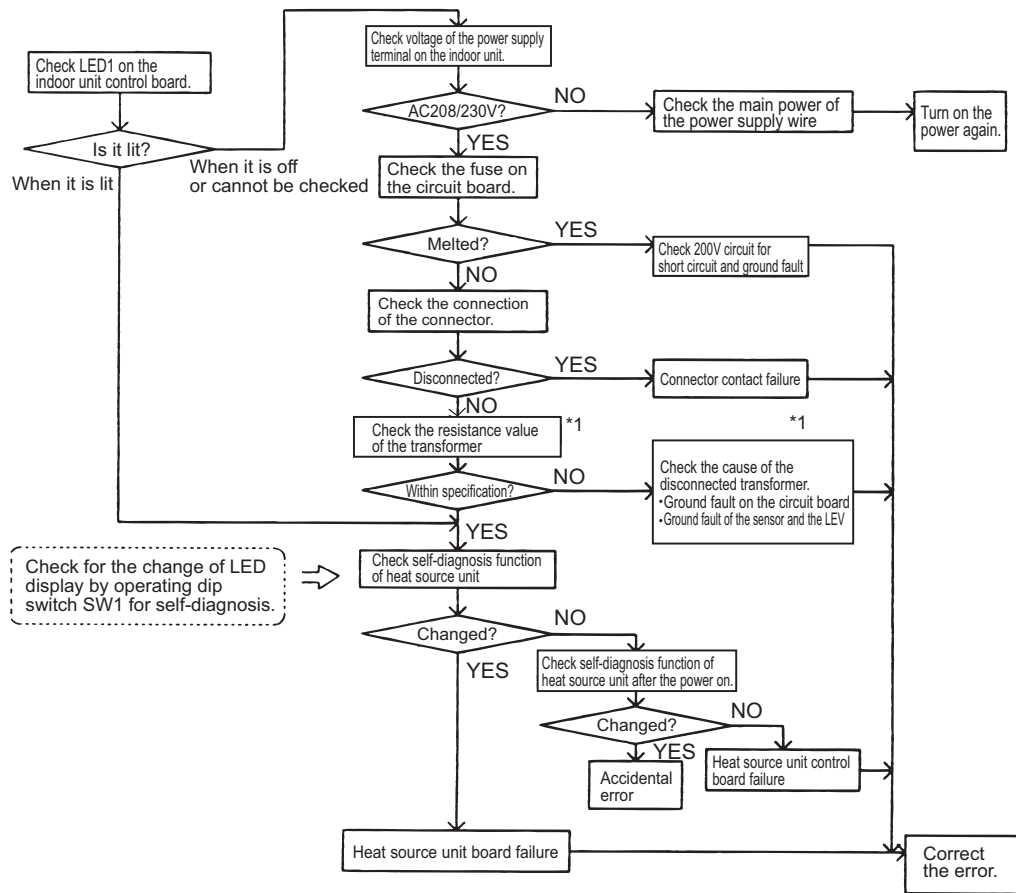

In case of ME remote controller

3. Phenomena

"HO" display on the remote controller does not disappear, and no operation is performed even if the button is pressed.

(1) Cause

Without using MELANS

- 1) Heat source unit address is set to "00"
- 2) A wrong address is set.
 - ♦The address of the indoor unit that is connected to the remote controller is incorrect. (It should equal the ME remote controller address plus 100.)
 - ♦A wrong address is set to the ME remote controller. (100 must be added to the address of the indoor unit.)
- 3) Faulty wiring of the terminal block for transmission line (TB5) of the indoor unit in the same group with the remote controller.
- 4) The centralized control switch (SW5-1) on the heat source unit is set to ON.
- 5) Disconnection or faulty wiring of indoor unit transmission line.
- 6) Disconnection between the terminal block for M-NET line connection (TB5) of the indoor unit and the male connector (CN2M)
- 7) The male power supply connectors on 2 or more heat source units are connected to the female power supply switch connector (CN40) for the transmission line for centralized control.
- 8) Heat source unit control board failure
- 9) Indoor unit control board failure
- 10) Remote controller failure

Interlocking control with MELANS

- 1) No group registration is made using MELANS. (The indoor unit and the ME remote controller are not grouped.)
- 2) Disconnected transmission line for centralized control (TB7) of the heat source unit
- 3) The male power supply connector is connected to CN40 on more than one heat source unit, or the connector is connected to CN40 on the heat source unit in the system to which a power supply unit for transmission line is connected.

Using MELANS

- 1) When MELANS is used, "HO" display on the remote controller will disappear when the indoor unit and the local remote controller (ME remote controller) are grouped.
If "HO" does not disappear after the registration, check the causes (2) 1) - 3).

(2) Check method and remedy

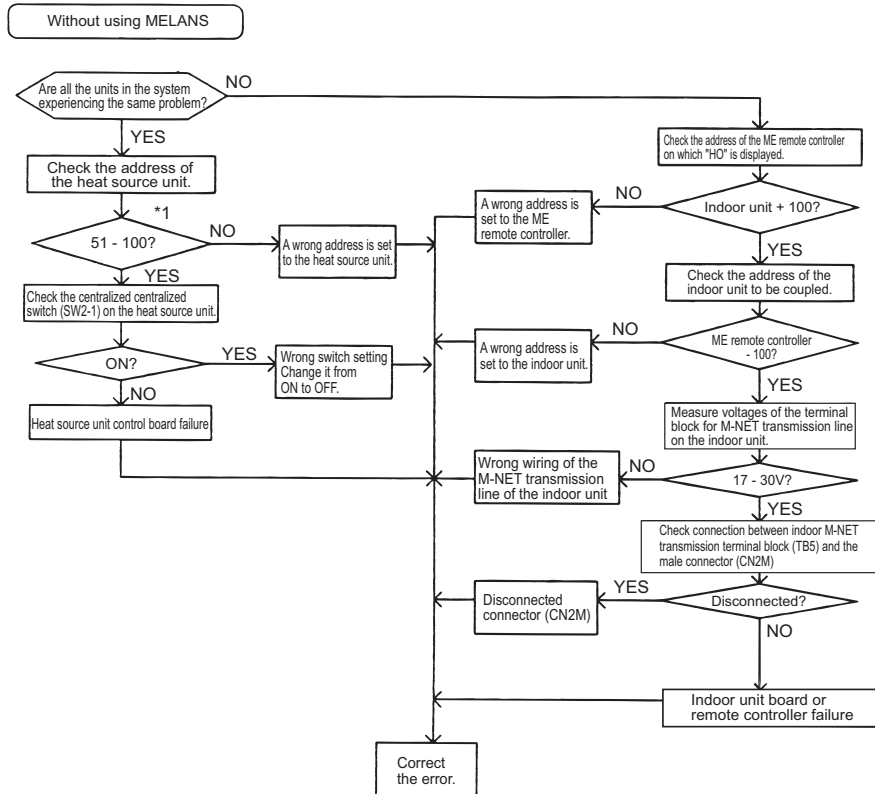

*1. When the heat source unit address is set to 1 - 50, the address will be forcibly set to 100.

In case of ME remote controller

4. Phenomena

"88" appears on the remote controller when the address is registered or confirmed.

(1) Cause, check method and remedy



Cause	Check method and remedy
An error occurs when the address is registered or confirmed. (common)	
1. A wrong address is set to the unit to be coupled.	(1) Confirm the address of unit to be coupled.
2. The transmission line of the unit to be coupled is disconnected or is not connected.	(2) Check the connection of transmission line.
3. Circuit board failure of the unit to be coupled	(3) Check voltage of the terminal block for transmission line of the unit to be coupled.
4. Improper transmission line work	1) Normal if voltage is between DC17 and 30V. 2) Check (4) in case other than 1).
Generates at interlocking registration between LOSSNAY and the indoor unit	
5. The power of LOSSNAY is OFF.	(4) Check for the main power of LOSSNAY.
Generates at confirmation of controllers used in the system in which the indoor units connected to different heat source units are grouped	
6. The power of the heat source unit to be confirmed has been cut off.	(5) Check the power supply of the heat source unit which is coupled with the unit to be confirmed.
7. The power of the heat source unit to be confirmed has been cut off.	(6) Check that the transmission line for centralized control (TB7) of the heat source unit is not disconnected.
8. When the indoor units connected to different heat source units are grouped without MELANS, the male power supply connector is not connected to the female power supply switch connector (CN40) for the transmission line for centralized control.	(7) Check voltage of the transmission line for centralized control.
9. The male power supply connectors on 2 or more heat source units are connected to the female power supply switch connector (CN40) for the transmission line for centralized control.	1) Normal when voltage is between 10V and 30V
10. In the system to which MELANS is connected, the male power supply connector is connected to the female power supply switch connector (CN40) for the transmission line for centralized control.	2) Check 8 - 11 described on the left in case other than 1).
11. Short circuit of the transmission line for centralized control	

Both for MA remote controller and ME remote controller

1. Phenomena

Although cooling operation starts with the normal remote controller display, the capacity is not enough

(1) Cause, check method and remedy

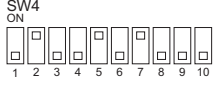
Cause	Check method and remedy
<p>1. Compressor frequency does not rise sufficiently.</p> <ul style="list-style-type: none"> •Faulty detection of pressure sensor. •Protection works and compressor frequency does not rise due to high discharge temperature •Protection works and compressor frequency does not rise due to high pressure •Pressure drops excessively. •The high temperature of the heatsink on the INV board triggers the protection mechanism that keeps the compressor frequency from rising. 	<p>(1) Check pressure difference between the detected pressure by the pressure sensor and the actual pressure with self-diagnosis LED. -> If the accurate pressure is not detected, check the pressure sensor. (Refer to the page on Troubleshooting of Pressure Sensor).</p> <p>Note: Lower inlet pressure by the low pressure sensor than the actual pressure causes insufficient capacity. SW4 setting (SW6-10: OFF)</p> <p>High pressure sensor </p> <p>Low pressure sensor </p> <p>(2) Check temperature difference between the evaporating temperature (Te) and the target evaporating temperature (Tem) with self-diagnosis LED.</p> <p>Note: Higher Te than Tem causes insufficient capacity. SW4 setting (SW6-10: OFF)</p> <p>Evaporating temperature Te </p> <p>Target evaporating temperature Tem </p> <p>Note: Protection works and compressor frequency does not rise even at higher Te than Tem due to high discharge temperature and high pressure. At high discharge temperature: Refer to 1102. At high pressure: Refer to 1302.</p> <p>(3) Fan problem, fan connection fault Check to see if the fan is rotating while the heat-source unit is in operation. If the fan is rotating ->Check the items listed under 4230. If the fan is not rotating -> Check the fan wires for proper connection. If the fan wires are properly connected, check that the voltage at the connector CN502 on the control board (Across CN502 and CN503 in the case of P216/240 TLMU-A1) is 188 V or above (with the heat-source unit in operation). If this value is normal, there is a problem with the fan.</p>
<p>2. Indoor unit LEV malfunction</p> <ul style="list-style-type: none"> •Insufficient refrigerant flows due to LEV malfunction (not enough opening) or protection works and compressor frequency does not rise due to pressure drop. •Refrigerant leak from LEV on the stopping unit causes refrigerant shortage on the running unit. 	<p>Refer to the page of LEV troubleshooting ([4] -4-).</p>

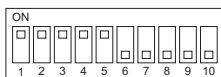



The figure at left shows that the switches 1 through 5 are set to ON and 6 through 10 are set to OFF.

Cause	Check method and remedy
3. Long piping length The cooling capacity varies greatly depending on the pressure loss. (When the pressure loss is large, the cooling capacity drops.)	Check the piping length to determine if it is contributing to performance loss. Piping pressure loss can be estimated from the temperature difference between the indoor unit heat exchanger outlet temperature and the saturation temperature (Te) of 63LS. ->Correct the piping.
4. Piping size is not proper (thin)	
5. Insufficient refrigerant amount Protection works and compressor frequency does not rise due to high discharge temperature.	Refer to 1-1. (Compressor frequency does not rise sufficiently.) Refer to the page on refrigerant amount adjustment.
6. Clogging by foreign object	Check the temperature difference between in front of and behind the place where the foreign object is clogging the pipe (upstream side and downstream side). When the temperature drops significantly, the foreign object may clog the pipe. -> Remove the foreign object inside the pipe.
7. The indoor unit inlet temperature is excessively. (Less than 15°C [59°F] WB)	Check the inlet air temperature and for short cycling. Change the environment where the indoor unit is used.
8. Compressor failure The amount of circulating refrigerant decreases due to refrigerant leak in the compressor.	Check the discharge temperature to determine if the refrigerant leaks, as it rises if there is a leak.
9. LEV3 malfunction Sufficient liquid refrigerant is not be supplied to the indoor unit as sufficient sub cool cannot be secured due to LEV3 malfunction.	Refer to the page of LEV troubleshooting ([4] -4-). It most likely happens when there is little difference or no difference between TH12 and TH15.
10. TH12, TH15 and 63HS1 sensor failure or faulty wiring LEV3 is not controlled normally.	<ul style="list-style-type: none"> •Check the thermistor. •Check wiring.

2. Phenomena

Although heating operation starts with the normal remote controller display, the capacity is not enough.

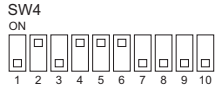
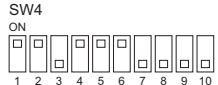
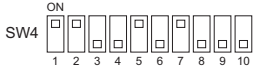
(1) Cause, check method and remedy

Cause	Check method and remedy
<p>1. Compressor frequency does not rise sufficiently.</p> <ul style="list-style-type: none"> •Faulty detection of pressure sensor. •Protection works and compressor frequency does not rise due to high discharge temperature •Protection works and compressor frequency does not rise due to high pressure. •The high temperature of the heatsink on the INV board triggers the protection mechanism that keeps the compressor frequency from rising. 	<p>(1) Check pressure difference between the detected pressure by the pressure sensor and the actual pressure with self-diagnosis LED. -> If the accurate pressure is not detected, check the pressure sensor.(Refer to the page on Troubleshooting of Pressure Sensor)</p> <p>Note: Higher inlet pressure by the high pressure sensor than the actual pressure causes insufficient capacity. SW4 setting (SW6-10: OFF)</p> <p>High pressure sensor </p> <p>Low pressure sensor </p> <p>(2) Check the difference between the condensing temperature (Tc) and the target condensing temperature (Tcm) with self-diagnosis LED.</p> <p>Note: Higher Tc than Tcm causes insufficient capacity. SW4 setting (SW6-10: OFF)</p> <p>Condensing temperature Tc </p> <p>Target condensing temperature Tcm </p> <p>Note: Protection works and compressor frequency does not rise even at lower Tc than Tcm due to high discharge temperature and high pressure. At high discharge temperature: Refer to 1102. At high pressure: Refer to 1302.</p> <p>(3) Fan problem, fan connection fault Check to see if the fan is rotating while the heat-source unit is in operation. If the fan is rotating ->Check the items listed under 4230. If the fan is not rotating -> Check the fan wires for proper connection. If the fan wires are properly connected, check that the voltage at the connector CN502 on the control board (Across CN502 and CN503 in the case of P216/240 TLMU-A1) is 188 V or above (with the heat-source unit in operation). If this value is normal, there is a problem with the fan.</p>

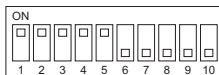

The figure at left shows that the switches 1 through 5 are set to ON and 6 through 10 are set to OFF.

Cause	Check method and remedy
2. Indoor unit LEV malfunction Insufficient refrigerant flows due to LEV malfunction (not enough opening).	Refer to the page of LEV troubleshooting ([4] -4-).
3. Temperature reading error on the indoor unit piping temperature sensor If the temperature reading on the sensor is higher than the actual temperature, it makes the subcool seem smaller than it is, and the LEV opening decreases too much.	Check the thermistor.
4. Insulation failure of the refrigerant piping	
5. Long piping length Excessively long piping on the high pressure side causes pressure loss leading to increase in the high pressure.	Confirm that the characteristic of capacity drop due to piping length. -> Change the pipe
6. Piping size is not proper (thin)	
7. Clogging by foreign object	Check the temperature difference between the upstream and the downstream of the pipe section that is blocked. Since blockage in the extended section is difficult to locate, operate the unit in the cooling cycle, and follow the same procedures that are used to locate the blockage of pipe during cooling operation. ->Remove the blockage in the pipe.
8. The indoor unit inlet temperature is excessively high.(exceeding 28°C [82°F])	Check the inlet air temperature and for short cycling. Change the environment where the indoor unit is used.
9. Insufficient refrigerant amount Protection works and compressor frequency does not rise due to low discharge temperature Refrigerant recovery operation is likely to start.	Refer to 2 - 1. (Compressor frequency does not rise sufficiently.) Refer to the page on refrigerant amount adjustment.
10. Compressor failure (same as in case of cooling)	Check the discharge temperature.
11. LEV3 actuation failure A drop in the low pressure that is caused either by a blockage of liquid pipe or by a pressure loss and the resultant slowing of refrigerant flow causes a tendency for the discharge temperature to rise.	Refer to the page on troubleshooting the LEV ([4] -4-).

3. Phenomena

Heat source unit stops at times during operation.

(1) Cause, check method and remedy

Cause	Check method and remedy
<p>The first stop is not considered as an error, as the unit turns to anti-restart mode for 3 minutes as a preliminary error.</p> <p>Error mode</p> <p>1 Abnormal high pressure</p> <p>2 Abnormal discharge air temperature</p> <p>3 Heatsink thermistor failure</p> <p>4 Thermistor failure</p> <p>5 Pressure sensor failure</p> <p>6 Over-current break</p> <p>7 Refrigerant overcharge</p> <p>Note1: Frost prevention tripping only under cooling mode may be considered in addition to the above. (Freeze protection is detected by one or all indoor units.)</p> <p>Note2: Even the second stop is not considered as an error when some specified errors occur. (eg. The third stop is considered as an error when the thermistor error occurs.)</p>	<p>(1) Check the mode operated in the past by displaying preliminary error history on LED display with SW4.</p> <p>(2) Reoperate the unit to find the mode that stops the unit by displaying preliminary error history on LED display with SW4.</p> <p>-> Refer to the reference page for each error mode. *Display the indoor piping temperature table with SW4 to check whether the freeze proof operation runs properly, and check the temperature.</p>

[3] Investigation of Transmission Wave Shape/Noise

1. M-NET transmission

Control is performed by exchanging signals between the heat source unit and the indoor unit (ME remote controller) through M-NET transmission. Noise interference on the transmission line will interrupt the normal transmission, leading to erroneous operation.

(1) Symptoms caused by noise interference on the transmission line

Cause	Erroneous operation	Error code	Error code definition
Noise interference on the transmission line	Signal is transformed and will be misjudged as the signal of another address.	6600	Address overlap
	Transmission wave pattern is transformed due to the noise creating a new signal	6602	Transmission processor hardware error
	Transmission wave pattern is transformed due to the noise, and will not be received normally leading to no acknowledgement (ACK).	6607	No ACK error
	Transmission cannot be performed due to the fine noise.	6603	Transmission line bus busy error
	Transmission is successful; however, the acknowledgement (ACK) or the response cannot be received normally due to the noise.	6607 6608	No ACK error No response error

(2) Wave shape check

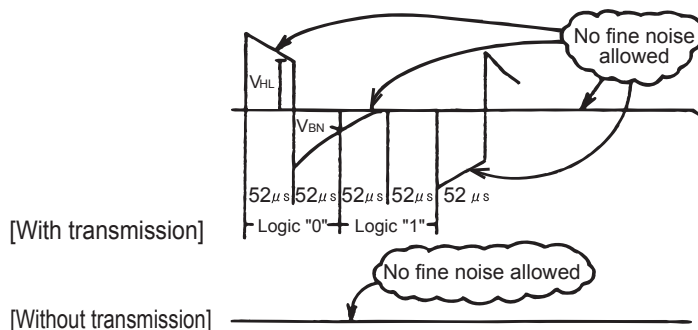

Wave shape check

Check the wave pattern of the transmission line with an oscilloscope. The following conditions must be met.

- Small wave pattern (noise) must not exist on the transmission signal. (Minute noise (approximately 1V) can be generated by DC-DC converter or the inverter operation; however, such noise is not a problem when the shield of the transmission line is grounded.)
- The sectional voltage level of transmission signal should be as follows.

Logic	Voltage level of the transmission line
0	$V_{HL} = 2.5V$ or higher
1	$V_{BN} = 1.3V$ or below

(3) Check method and remedy

1) Measures against noise

Check the followings when noise exists on the wave or the errors described in (1) occur.

	Error code definition	Remedy
Check that the wiring work is performed according to wiring specifications.	1. The transmission line and the power line are not wired too closely.	Isolate the transmission line from the power line (5cm [1-31/32"] or more). Do not insert them in the same conduit.
	2. The transmission line is not bundled with that for another systems.	The transmission line must be isolated from another transmission line. When they are bundled, erroneous operation may be caused.
	3. The specified wire is used for the transmission line.	Use the specified transmission line. Type: Shielded wire CVVS/CPEVS/MVVS (For ME remote controller) Diameter: 1.25mm ² [AWG16] or more (Remote controller wire: 0.3 - 1.25mm ² [AWG22-16])
	4. When the transmission line is daisy-chained on the indoor unit terminals, are the shields daisy-chained on the terminals, too?	The transmission is two-wire daisy-chained. The shielded wire must be also daisy-chained. When the shielded cable is not daisy-chained, the noise cannot be reduced enough.
Check that the grounding work is performed according to grounding specifications.	5. Is the shield of the indoor-heat source transmission cable grounded to the earth terminal on the heat source unit?	Connect the shield of the indoor-heat source transmission cable to the earth terminal (♯) on the heat source unit. If no grounding is provided, the noise on the transmission line cannot escape leading to change of the transmission signal.
	6. Check the treatment method of the shield of the transmission line (for centralized control).	The transmission cable for centralized control is less subject to noise interference if it is grounded to the heat source unit whose power jumper cable was moved from CN41 to CN40 or to the power supply unit. The environment against noise varies depending on the distance of the transmission lines, the number of the connected units, the type of the controllers to be connected, or the environment of the installation site. Therefore, the transmission line work for centralized control must be performed as follows. (1) When no grounding is provided: Ground the shield of the transmission cable by connecting to the heat source unit whose power jumper connector was moved from CN41 to CN40 or to the power supply unit. (2) When an error occurs even though one point grounding is provided: Ground the shield on all heat source units.

2) Check the followings when the error "6607" occurs, or "HO" appears on the display on the remote controller.

Error code definition	Remedy
7. The farthest distance of transmission line is 200m [656ft] or longer.	Check that the farthest distance from the heat source unit to the indoor unit and to the remote controller is within 200m [656ft].
8. The types of transmission lines are different.	Use the specified transmission line. Type: Shielded wire CVVS/CPEVS/MVVS (For ME remote controller) Diameter: 1.25mm ² [AWG16] or more (Remote controller wire: 0.3-1.25mm ² [AWG22-16])
9. Heat source unit circuit board failure	Replace the heat source unit control board or the power supply board for the transmission line.
10. Indoor unit circuit board failure or remote controller failure	Replace the indoor unit circuit board or the remote controller.
11. The MA remote controller is connected to the M-NET transmission line.	Connect the MA remote controller to the terminal block for MA remote controller (TB15).

2. MA remote controller transmission

The communication between the MA remote controller and the indoor unit is performed with current tone burst.

(1) Symptoms caused by noise interference on the transmission line

If noise is generated on the transmission line, and the communication between the MA remote controller and the indoor unit is interrupted for 3 minutes in a row, MA transmission error (6831) will occur.

(2) Confirmation of transmission specifications and wave pattern

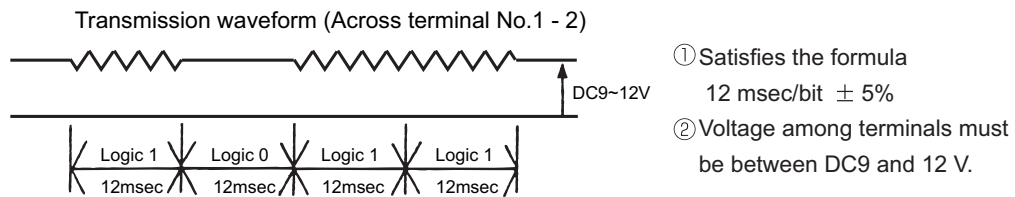
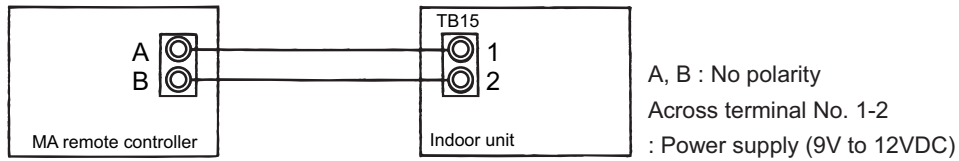

[4] Troubleshooting Principal Parts

-1- High-Pressure Sensor (63HS1, PS1, PS3)

1. Compare the pressure that is detected by the high pressure sensor, and the high-pressure gauge pressure to check for failure.

By configuring the digital display setting switch SW4 (SW6-10: OFF) as shown in the figure below, the pressure as measured by the high-pressure sensor appears on the LED1 on the control board.

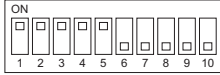
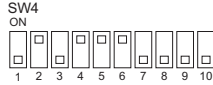

The figure at left shows that the switches 1 through 5 are set to ON and 6 through 10 are set to OFF.

(1) While the sensor is stopped, compare the gauge pressure and the pressure displayed on self-diagnosis LED1.

- 1) When the gauge pressure is between 0 and 0.098MPa [14psi], internal pressure is caused due to gas leak.
- 2) When the pressure displayed on self-diagnosis LED1 is between 0 and 0.098MPa [14psi], the connector may be defective or be disconnected. Check the connector and go to (4).
- 3) When the pressure displayed on self-diagnosis LED1 exceeds 4.15MPa [601psi], go to (3).
- 4) If other than 1), 2) or 3), compare the pressures while the sensor is running. Go to (2).

(2) Compare the gauge pressure and the pressure displayed on self-diagnosis LED1 while the sensor is running. (Compare them by MPa [psi] unit.)

- 1) When the difference between both pressures is within 0.098MPa [14psi], both the high pressure sensor and the control board are normal.
- 2) When the difference between both pressures exceeds 0.098MPa [14psi], the high pressure sensor has a problem. (performance deterioration)
- 3) When the pressure displayed on self-diagnosis LED1 does not change, the high pressure sensor has a problem.

(3) Remove the high pressure sensor from the control board to check the pressure on the self-diagnosis LED1.

- 1) When the pressure displayed on self-diagnosis LED1 is between 0 and 0.098MPa [14psi], the high pressure sensor has a problem.
- 2) When the pressure displayed on self-diagnosis LED1 is approximately 4.15MPa [601psi], the control board has a problem.

(4) Remove the high pressure sensor from the control board, and short-circuit between the No.2 and 3 connectors (63HS1, PS1, PS3) to check the pressure with self-diagnosis LED1.

- 1) When the pressure displayed on the self-diagnosis LED1 exceeds 4.15MPa [601psi], the high pressure sensor has a problem.
- 2) If other than 1), the control board has a problem.

2. Pressure sensor configuration

The high pressure sensor consists of the circuit shown in the figure below. If DC 5V is applied between the red and the black wires, voltage corresponding to the pressure between the white and the black wires will be output, and the value of this voltage will be converted by the microcomputer. The output voltage is 0.071V per 0.098MPa [14psi].

Note

The pressure sensor on the body side is designed to connect to the connector. The connector pin number on the body side is different from that on the control board side.

	Body side	Control board side
Vcc	Pin 1	Pin 3
Vout	Pin 2	Pin 2
GND	Pin 3	Pin 1

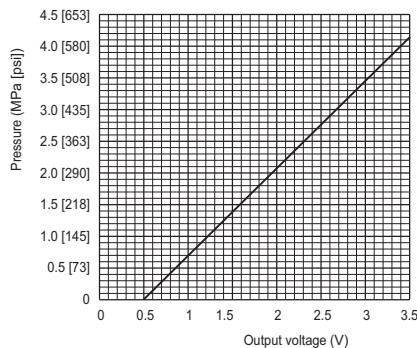
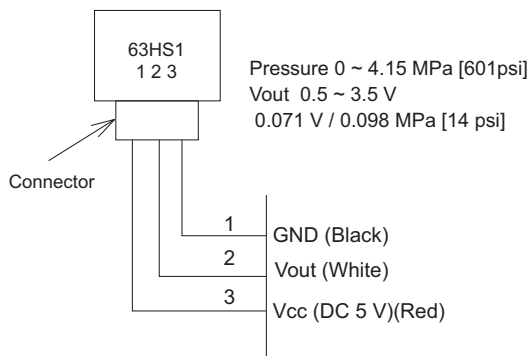

-2- Low-Pressure Sensor (63LS)

1. Compare the pressure that is detected by the low pressure sensor, and the low pressure gauge pressure to check for failure.

By configuring the digital display setting switch SW4 (SW6-10: OFF) as shown in the figure below, the pressure as measured by the low-pressure sensor appears on the LED1 on the control board.

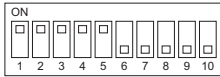

The figure at left shows that the switches 1 through 5 are set to ON and 6 through 10 are set to OFF.

(1) While the sensor is stopped, compare the gauge pressure and the pressure displayed on self-diagnosis LED1.

- 1) When the gauge pressure is between 0 and 0.098MPa [14psi], internal pressure is caused due to gas leak.
- 2) When the pressure displayed on self-diagnosis LED1 is between 0 and 0.098MPa [14psi], the connector may be defective or be disconnected. Check the connector and go to (4).
- 3) When the pressure displayed on self-diagnosis LED1 exceeds 1.7MPa [247psi], go to (3).
- 4) If other than 1), 2) or 3), compare the pressures while the sensor is running. Go to (2).

(2) Compare the gauge pressure and the pressure displayed on self-diagnosis LED1 while the sensor is running.(Compare them by MPa [psi] unit.)

- 1) When the difference between both pressures is within 0.03MPa [4psi], both the low pressure sensor and the control board are normal.
- 2) When the difference between both pressures exceeds 0.03MPa [4psi], the low pressure sensor has a problem. (performance deterioration)
- 3) When the pressure displayed on the self-diagnosis LED1 does not change, the low pressure sensor has a problem.

(3) Remove the low pressure sensor from the control board to check the pressure with the self-diagnosis LED1 display.

- 1) When the pressure displayed on the self-diagnosis LED1 is between 0 and 0.098MPa [14psi], the low pressure sensor has a problem.
- 2) When the pressure displayed on self-diagnosis LED1 is approximately 1.7MPa [247psi], the control board has a problem.
 - When the heat source temperature is 30°C [86°F] or less, the control board has a problem.
 - When the heat source temperature exceeds 30°C [86°F], go to (5).

(4) Remove the low pressure sensor from the control board, and short-circuit between the No.2 and 3 connectors (63LS:CN202) to check the pressure with the self-diagnosis LED1.

- 1) When the pressure displayed on the self-diagnosis LED1 exceeds 1.7MPa [247psi], the low pressure sensor has a problem.
- 2) If other than 1), the control board has a problem.

(5) Remove the high pressure sensor (63HS1) from the control board, and insert it into the connector for the low pressure sensor (63LS) to check the pressure with the self-diagnosis LED1.

- 1) When the pressure displayed on the self-diagnosis LED1 exceeds 1.7MPa [247psi], the control board has a problem.
- 2) If other than 1), the control board has a problem.

2. Low-pressure sensor configuration

The low pressure sensor consists of the circuit shown in the figure below. If DC5V is applied between the red and the black wires, voltage corresponding to the pressure between the white and the black wires will be output, and the value of this voltage will be converted by the microcomputer. The output voltage is 0.173V per 0.098MPa [14psi].

Note

The pressure sensor on the body side is designed to connect to the connector. The connector pin number on the body side is different from that on the control board side.

	Body side	Control board side
Vcc	Pin 1	Pin 3
Vout	Pin 2	Pin 2
GND	Pin 3	Pin 1

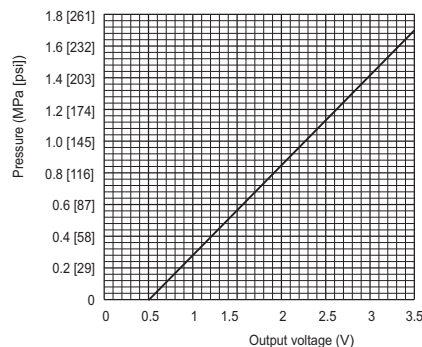
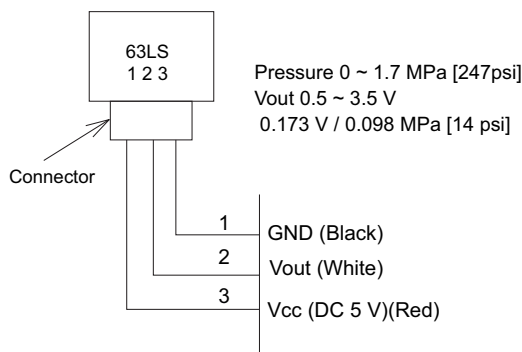

-3- Solenoid Valve



Check whether the output signal from the control board and the operation of the solenoid valve match.

Setting the self-diagnosis switch SW4 (SW6-10: OFF) as shown in the figure below causes the ON signal of each relay to be output to the LED's.

Each LED shows whether the relays for the following parts are ON or OFF. LEDs light up when relays are on.

Note

The circuits on some parts are closed when the relays are ON. Refer to the following instructions.

SW4 (SW6-10: OFF)		Display							
		LD1	LD2	LD3	LD4	LD5	LD6	LD7	LD8
	Upper	21S4a		CH11		SV1a			
	Lower			21S4b					
	Upper	SV4a	SV4b				SV4d	SV9	
	Lower	SV7a	SV7b		SV7c				

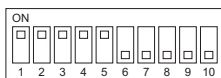

The figure at left shows that the switches 1 through 5 are set to ON and 6 through 10 are set to OFF.

When a valve malfunctions, check if the wrong solenoid valve coil is not attached the lead wire of the coil is not disconnected, the connector on the board is not inserted wrongly, or the wire for the connector is not disconnected.

Note

The PQHY model does not have SV4a, 4b, or 4d.

(1) In case of 21S4a (4-way switching valve)

About this 4-way valve

When not powered:

Conducts electricity between the oil separator outlet and heat exchanger AND the gas ball valve (BV1) and the accumulator to complete the circuit for the cooling cycle.

When powered:

The electricity runs between the oil separator and the gas ball valve, and between the heat exchanger and the accumulator. This circulation is for heating.

Check the LED display and the intake and the discharge temperature for the 4-way valve to check whether the valve has no faults and the electricity runs between where and where. Do not touch the pipe when checking the temperature, as the pipe on the oil separator side will be hot.

Note

Do not give an impact from outside, as the outer hull will be deformed leading to the malfunction of the inner valve.

(2) In case of SV1a (Bypass valve)

This solenoid valve opens when powered (Relay ON).

- 1) At compressor start-up, the SV1a turns on for 4 minutes, and the operation can be checked by the self-diagnosis LED display and the closing sound.
- 2) To check whether the valve is open or closed, check the change of the SV1a downstream piping temperature while the valve is being powered. Even when the valve is closed, high-temperature refrigerant flows inside the capillary next to the valve. (Therefore, temperature of the downstream piping will not be low with the valve closed.)

(3) SV4a - 4d, SV7a, 7b, 7c (Controls heat exchanger capacity)

- 1) At least one of the solenoid valves among SV4a through 4d, SV7a, and SV7b, 7c turns on. Check for proper operation on the LED and by listening for the operation sound of the solenoid valve.
- 2) This diagram shows the flow of the high-temperature (high-pressure) gas refrigerant in the Cooling-only and Cooling-main modes and the flow of the low-temperature gas/liquid refrigerant in the Heating-only and Heating-main modes. Refer to the refrigerant circuit diagram. Solenoid valves turns on and off according to such factors as the capacity of the indoor units in operation and water inlet temperature. Check the LED. Remove the SV coil, open the lid, and check the plunger. The type of pin face wrench that is listed in the service parts list is required to perform this task.

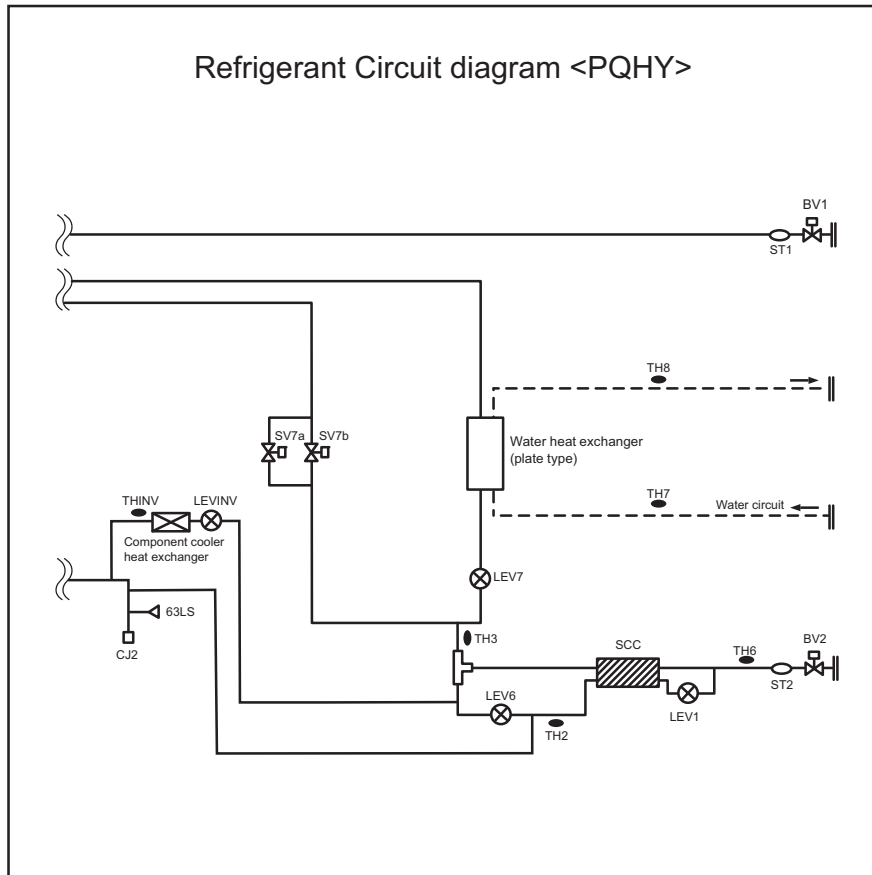

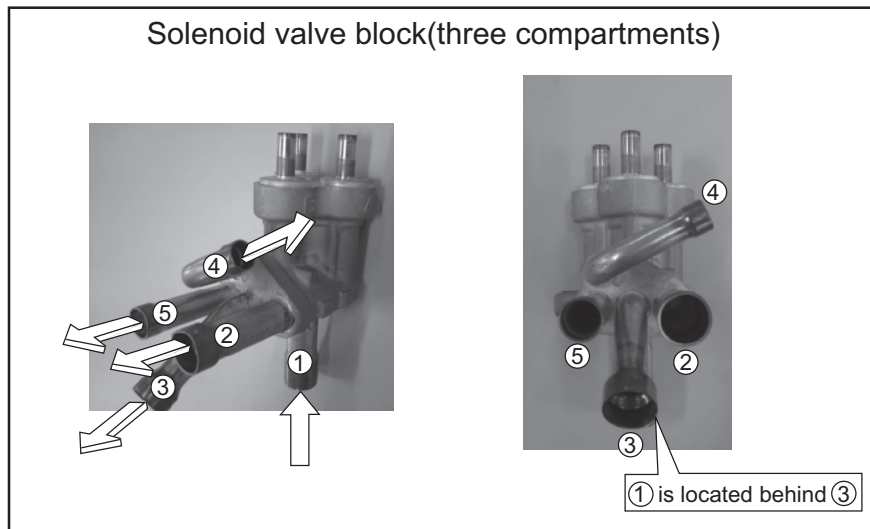
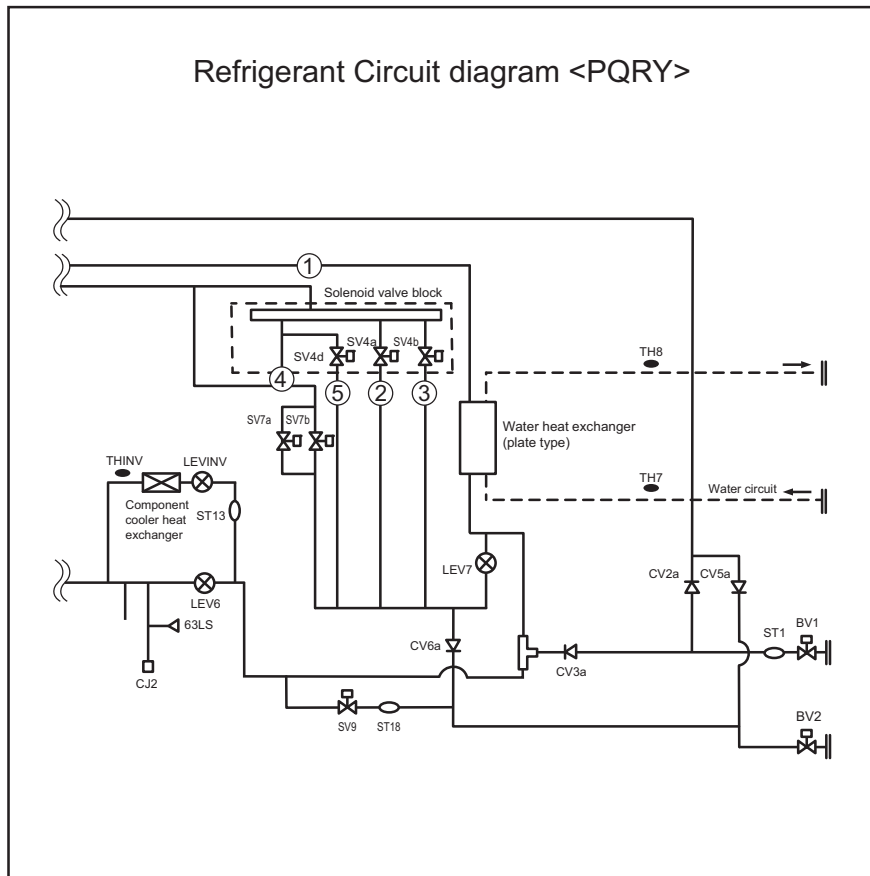

(4) In the case of SV9 (Bypass valve)

This solenoid valve opens when energized (when the relay is on)
 This valve turns on when the value of 63HS1 is greater than 3.5 MPa [507psi] during Heating-only or Heating-main operation at the minimum frequency. The valve position can be determined by measuring and monitoring the changes in the pipe temperature on the downstream of SV9 while the unit is energized. When the valve is open, high-temperature gas refrigerant passes through the pipe. Do not attempt to check the pipe temperature by touching the pipe.

-4- LEV

LEV operation

The LEV on the indoor unit and LEV1, LEVINV, LEV6, and LEV7 on the heat source unit are driven by the pulse signal from the circuit board on the indoor and heat-source units and are controlled by a stepping motor

(1) Indoor LEV, heat source LEV (LEV6, LEV7), and BC controller LEV (LEV1, LEV2, LEV3)

The valve opening changes according to the number of pulses.

- 1) Control boards (indoor unit and BC controller) and LEV (indoor unit LEV and BC controller LEV)

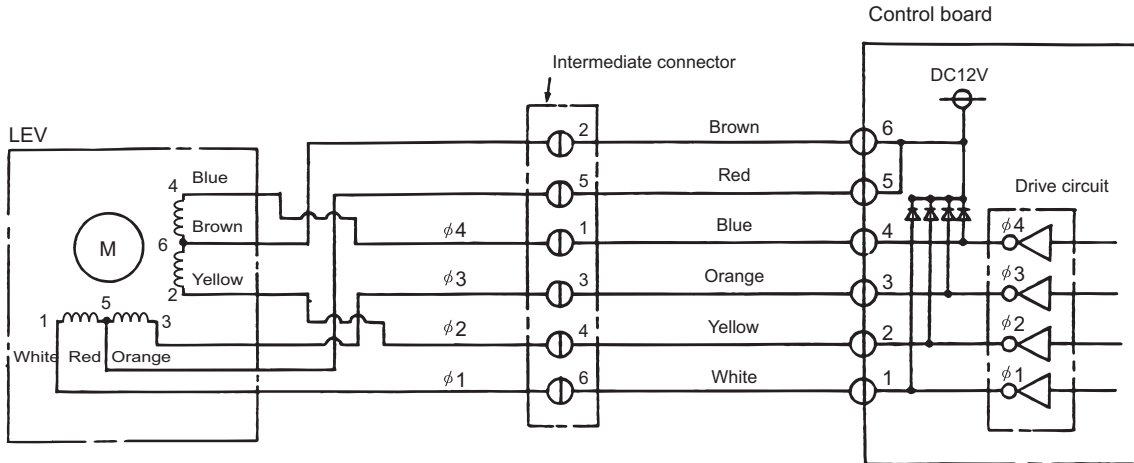

Note. The connector numbers on the intermediate connector and the connector on the control board differ. Check the color of the lead wire to judge the number.

- 2) Control boards (indoor unit, Heat source unit, and BC controller) and LEV (indoor unit LEV, Heat source unit, and BC controller LEV)

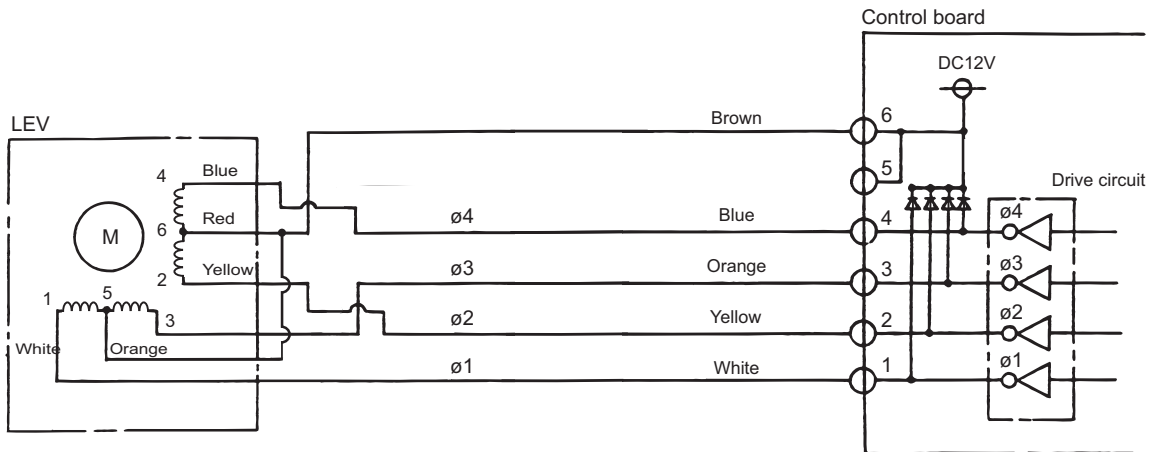

3) Pulse signal output and valve operation

Output (phase) number	Output state			
	1	2	3	4
φ 1	ON	OFF	OFF	ON
φ 2	ON	ON	OFF	OFF
φ 3	OFF	ON	ON	OFF
φ 4	OFF	OFF	ON	ON

Output pulses change in the following orders when the Valve is closed; 1 → 2 → 3 → 4 → 1
 Valve is open; 4 → 3 → 2 → 1 → 4

- *1. When the LEV opening angle does not change, all the output phases will be off.
- *2. When the output is open phase or remains ON, the motor cannot run smoothly, and rattles and vibrates.

4) LEV valve closing and opening operation

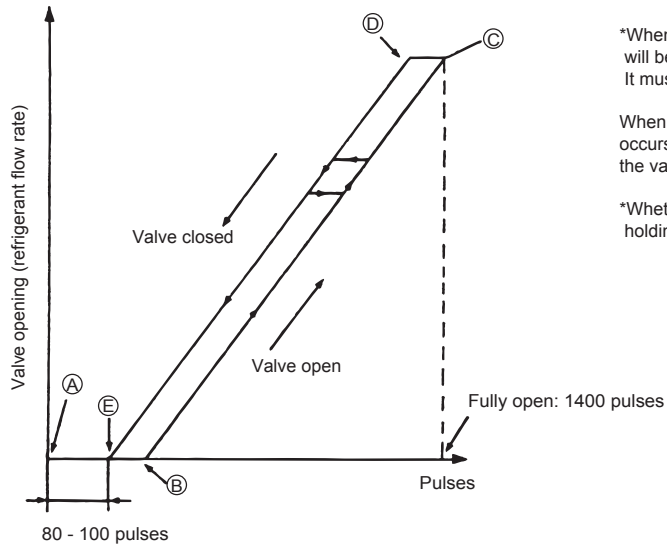

*When the power is turned on, the valve closing signal of 2200 pulses will be output from the indoor board to LEV to fix the valve position. It must be fixed at point A.

When the valve operates smoothly, no sound from LEV or no vibration occurs, however, when the pulses change from E to A in the chart or the valve is locked, a big sound occurs.

*Whether a sound is generated or not can be determined by holding a screwdriver against it, then placing your ear against the handle.

(2) Heat source LEV (LEV1,LEVINV)

The valve opening changes according to the number of pulses.

1) Connections between the heat source control board and LEV

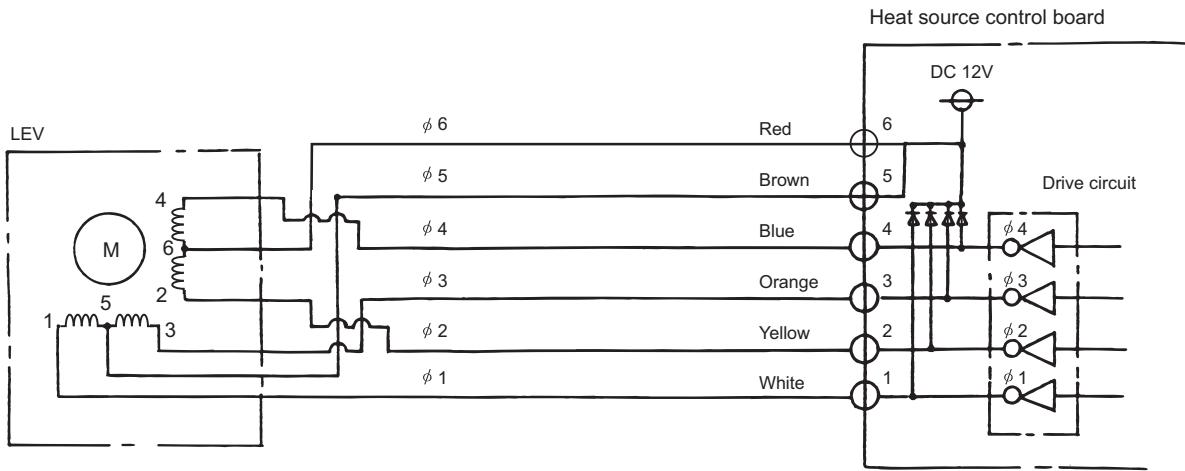

2) Pulse signal output and valve operation

Output (phase) number	Output state							
	1	2	3	4	5	6	7	8
$\phi 1$	ON	OFF	OFF	OFF	OFF	OFF	ON	ON
$\phi 2$	ON	ON	ON	OFF	OFF	OFF	OFF	OFF
$\phi 3$	OFF	OFF	ON	ON	ON	OFF	OFF	OFF
$\phi 4$	OFF	OFF	OFF	OFF	ON	ON	ON	OFF

Output pulses change in the following orders when the
 Valve is open; 1 → 2 → 3 → 4 → 5 → 6 → 7 → 8 → 1
 Valve is closed; 8 → 7 → 6 → 5 → 4 → 3 → 2 → 1 → 8

- *1. When the LEV opening angle does not change, all the output phases will be off.
- *2. When the output is open phase or remains ON, the motor cannot run smoothly, and rattles and vibrates.

3) LEV valve closing and opening operation

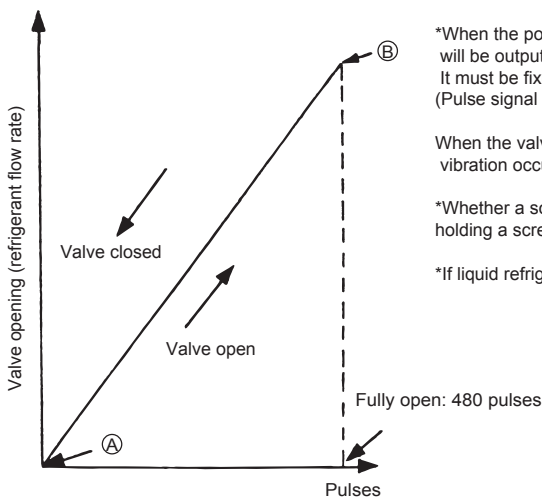

*When the power is turned on, the valve closing signal of 520 pulses will be output from the indoor board to LEV to fix the valve position. It must be fixed at point (A) (Pulse signal is output for approximately 17 seconds.)

When the valve operates smoothly, there is no sound from the LEV and no vibration occurs, but when the valve is locked, noise is generated.

*Whether a sound is generated or not can be determined by holding a screwdriver against it, then placing your ear against the handle.

*If liquid refrigerant flows inside the LEV, the sound may become smaller.

(3) Judgment methods and possible failure mode

Note

The specifications of the heat source unit (heat source LEV), indoor unit (indoor LEV), and BC controller (BC controller LEV) differ. Therefore, remedies for each failure may vary. Check the remedy specified for the appropriate LEV as indicated in the right column.

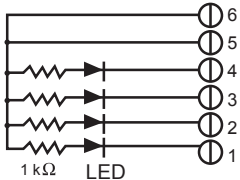
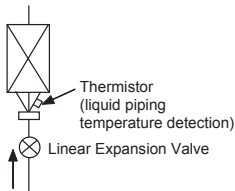
Malfunction mode	Judgment method	Remedy	Target LEV
Microcomputer driver circuit failure	<p>Disconnect the control board connector and connect the check LED as shown in the figure below.</p>  <p>resistance : 0.25W 1kΩ LED : DC15V 20mA or more</p> <p>When the main power is turned on, the indoor unit circuit board outputs pulse signals to the indoor unit LEV for 10 seconds, and the heat source unit circuit board outputs pulse signals to the heat source unit LEV for 17 seconds.</p> <p>If any of the LED remains lit or unlit, the drive circuit is faulty.</p>	When the drive circuit has a problem, replace the control board.	Indoor Heat source
LEV mechanism is locked	If the LEV is locked, the drive motor runs idle, and makes a small clicking sound. When the valve makes a closing and opening sound, the valve has a problem.	Replace the LEV.	Indoor Heat source BC controller
Disconnected or short-circuited LEV motor coil	Measure resistance between the coils (red - white, red - orange, brown - yellow, brown - blue) using a tester. They are normal if resistance is 150ohm ± 10%.	Replace the LEV coils.	Indoor BC controller
	Measure the resistance between coils (red-white, red-orange, red-yellow, red-blue) with a tester. When the resistance is in the range of 100ohm ± 10%, the LEV is normal.	Replace the LEV coils.	Heat source (LEV6,LEV7) BC controller
	Measure resistance between the coils (red - white, red -orange, brown - yellow, brown - blue) using a tester. They are normal if resistance is 46ohm ± 3%.	Replace the LEV coils.	Heat source (LEV1,LEVINV)
Incomplete sealing (leak from the valve)	<p>When checking the refrigerant leak from the indoor LEV, run the target indoor unit in the fan mode, and the other indoor units in the cooling mode. Then, check the liquid temperature (TH22) with the self-diagnosis LED. When the unit is running in the fan mode, the LEV is fully closed, and the temperature detected by the thermistor is not low. If there is a leak, however, the temperature will be low. If the temperature is extremely low compared with the inlet temperature displayed on the remote controller, the LEV is not properly sealed, however, if there is a little leak, it is not necessary to replace the LEV when there are no effects to other parts.</p> 	If there is a large amount of leakage, replace the LEV.	Indoor BC controller
Faulty wire connections in the connector or faulty contact	<ol style="list-style-type: none"> 1. Check for loose pins on the connector and check the colors of the lead wires visually 2. Disconnect the control board's connector and conduct a continuity check using a tester. 	Check the continuity at the points where an error occurs.	Indoor Heat source BC controller

(4) Heat source unit LEV (LEV1,LEVINV) coil removal procedure

1) LEV component

As shown in the figure, the heat source LEV is made in such a way that the coils and the body can be separated.

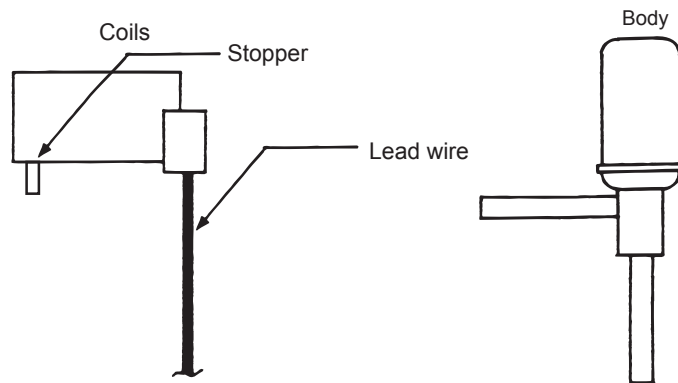

2) Removing the coils

Fasten the body tightly at the bottom (Part A in the figure) so that the body will not move, then pull out the coils toward the top. If the coils are pulled out without the body gripped, undue force will be applied and the pipe will be bent.

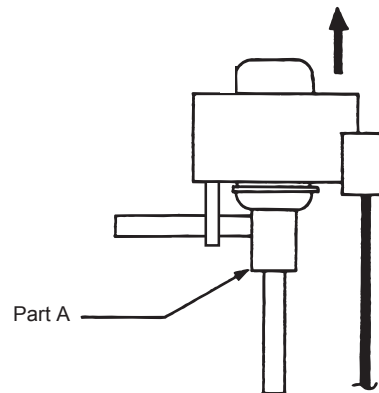

3) Installing the coils

Fix the body tightly at the bottom (Part A in the figure) so that the body will not move, then insert the coils from the top, and insert the coil stopper securely in the pipe on the body. Hold the body when pulling out the coils to prevent so that the pipe will not be bent.

If the coils are pushed without the body gripped, undue force will be applied and the pipe will be bent. Hold the body when pulling out the coils to prevent so that the pipe will not be bent.

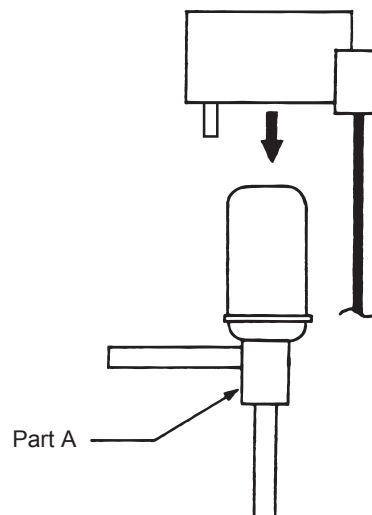

(5) Heat source unit LEV (LEV6,LEV7) and BC controller coil removal procedure

1) Components

The outdoor unit LEV consists of a coil and a valve body that can be separated from each other.

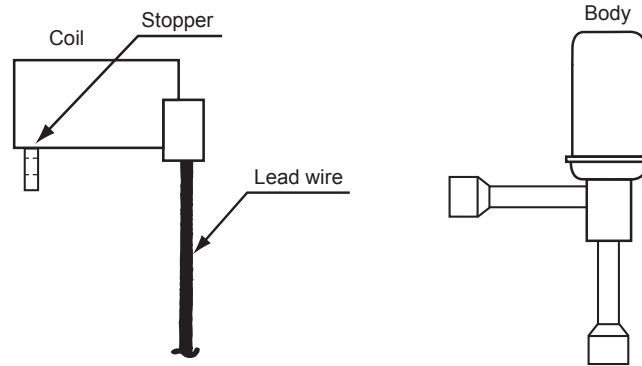

2) Removing the coil

Securely hold the LEV at the bottom (as indicated by A in the figure), and turn the coil. After checking that the stopper is removed, pull up and out the coil.

When removing the coil, hold the LEV body securely to prevent undue force from being placed on the pipe and bending the pipe.

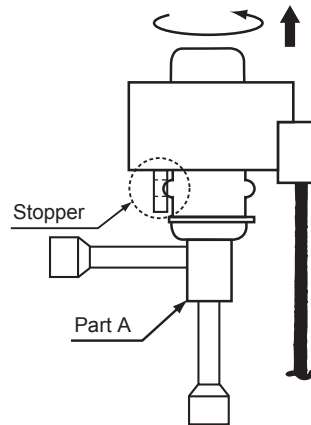

3) Installing the coil

Securely hold the bottom of the LEV (section A in the figure), insert the coil from above, and turn the coil until the coil stopper is properly installed on the LEV body.

When removing the coil, hold the LEV body securely to prevent undue force from being placed on the pipe and bending the pipe.

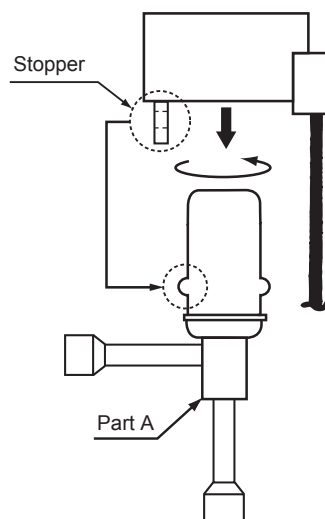

(6) Indoor unit LEV, BC controller LEV coil removal procedure

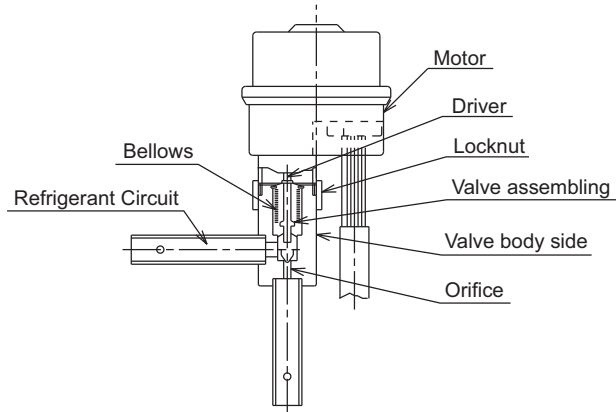

Notes on the procedure

- 1) Do not put undue pressure on the motor.
- 2) Do not use motors if dropped.
- 3) Do not remove the cap until immediately before the procedure.
- 4) Do not wipe off any molybdenum.
- 5) Do not remove the packing.
- 6) Do not apply any other than specified liquid such as screw lock agent, grease and etc.

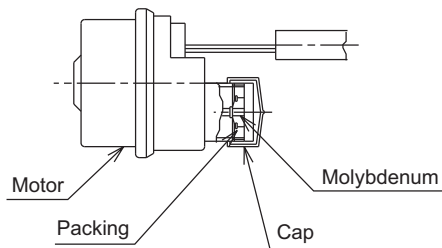

Replacement procedure

- 1) Stop the air conditioner. After checking that the air conditioner is stopped, turn off the power of the heat source unit.
- 2) Prepare two spanners. Hold the valve body with one spanner and loosen the locknut with another one.
Turning the locknut counter-clockwise from motor side view can loosen it.
Two spanners must be used.
Do not hold the motor with one hand and loosen the locknut with only one spanner.
- 3) Turning the locknut several times. The locknut will come off and then the motor can be removed.
- 4) Prepare a motor replacement. Use only factory settings, which the head part of the driver does not come out. **Use of other than factory settings may result in malfunction and failure of valve flow rate control.**
- 5) Keep dust, contaminants, and water out of the space between the motor and the valve body during replacement. (The space is the mechanical section of the valve.) Do not damage the junction with tools.
After removing the motor, **blow N₂ gas or etc. into bellows in order to blow off water from inside.**
- 6) Remove the cap of the motor replacement. Joint the axis of the motor and the one of the valve body with the locknut to stick precisely. **Apply screw lock agent to whole part of the screw. Do not introduce screw lock agent into the motor.** Use new motors if problems are found on the motor during the replacement.
- 7) After rotating the locknut 2~3 times by hands, hold the valve body with the spanner, and tighten the locknut with the specified torque with a torque wrench. Apply the tightening torque of 15N · m (150kgf · cm) (administration value 15 ± 1 N · m (150 ± 10kgf · cm)).
Note that undue tightening may cause breaking a flare nut.
- 8) When tightening the locknut, hold the motor with hands so that undue rotary torque and load can not be applied.
- 9) The differences of relative position after assembling the motor and the valve body do not affect the valve control and the switching function.
Do not relocate the motor and the valve body after tightening the locknut. Even the relative position is different from before and after assembling.

Difference in rotational direction is acceptable.

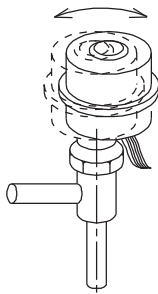

The motor may not be fixed with clamp because of the changing of the motor configuration. However, the fixing is not necessary due to the pipe fixing.

- 10) Connect the connector. Do not pull hard on the lead wire. Make sure that the connector is securely inserted into the specified position, and check that the connector does not come off easily.
- 11) Turn on the indoor unit, and operate the air conditioner. Check that no problems are found.

-5- Troubleshooting Principal Parts of BC Controller

1. Pressure sensor

Troubleshooting flow chart for pressure sensor

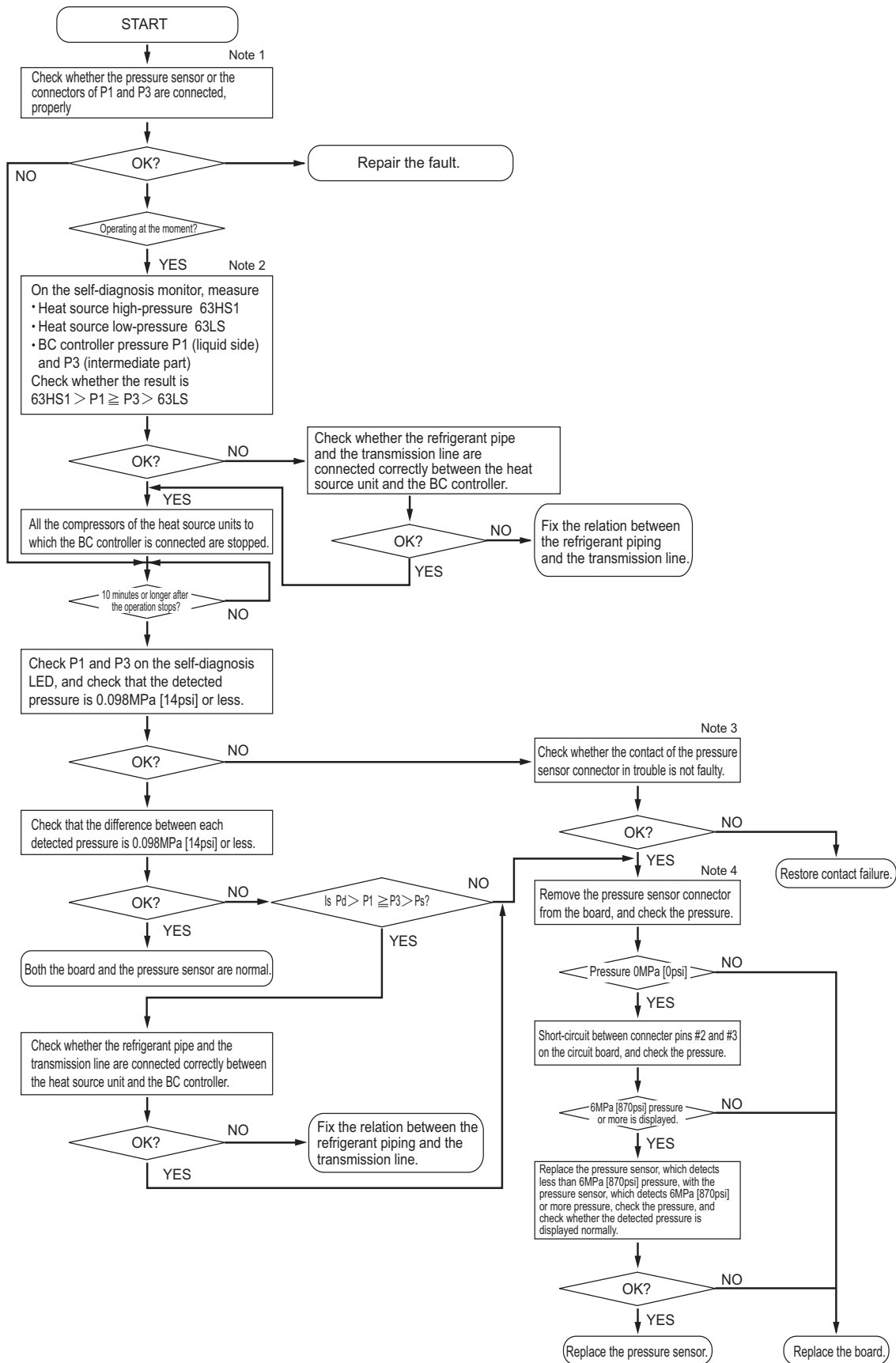

Note

- 1) BC controller: Phenomena when the pressure sensor is connected wrongly (reverse connection of P1 and P3) to the board.

Symptoms						
Cooling-only	Cooling-main		Heating only		Heating main	
Normal	Non-cooling	SC11 large SC16 small △PHM large	Indoor heating SC small Heating indoor Thermo ON Especially noise is large.	SC11 large SC16 small △PHM large	Non-cooling Indoor heating SC small Heating indoor Thermo ON Especially noise is large.	SC11 large SC16 small △PHM large

Note

- 2) Check the self-diagnosis switch (Heat source control board SW4 (SW6-10: OFF)).

Measurement data	Symbol	SW4 setting value
Heat source high pressure	63HS1	
Heat source low pressure	63LS	
BC controller pressure (liquid side)	PS1	
BC controller pressure (intermediate part)	PS3	

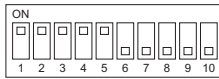

The figure at left shows that the switches 1 through 5 are set to ON and 6 through 10 are set to OFF.

Note

- 3) Check whether CNP1 (liquid side) connector on the BC controller control board and the connector CNP2 (intermediate part) are not disconnected or not loose.
- 4) Check the pressure value on the self-diagnosis switch (same as note 2) with the connector of the applied pressure sensor is disconnected from the board.

2. Temperature sensor

Troubleshooting instructions for thermistor

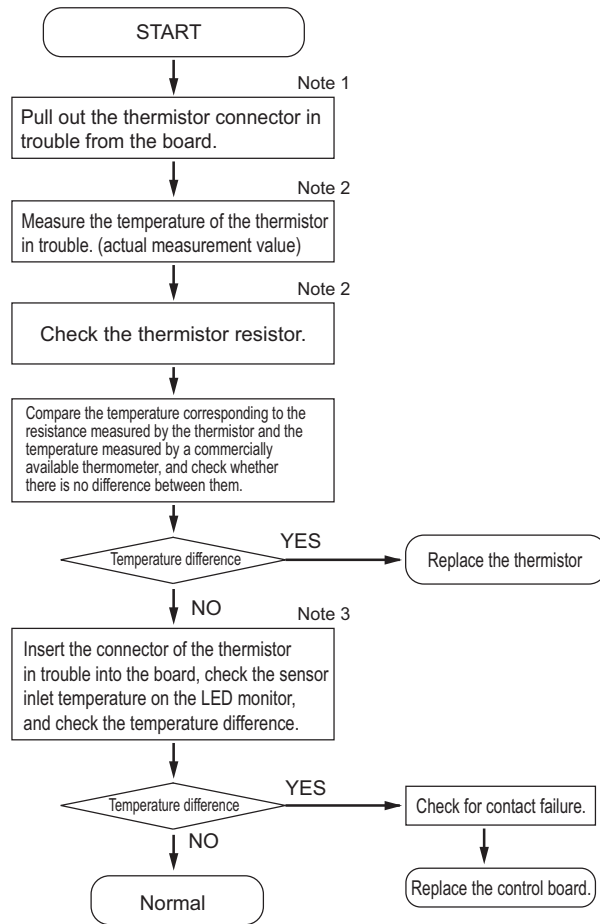

Note

- 1) For the connectors on the board, TH11 and TH12 are connected to CN10, and TH15 and TH16 are connected to CN11. Disconnect the connector in trouble, and check the sensor of each number.
- 2)
 - ◆Pull out the sensor connector from the I/O board, Do not pull the sensor by holding the lead wire.
 - ◆Measure the resistance with such as a tester.
 - ◆Compare the measured value with that of shown in the figure below. When the result is $\pm 10\%$, it is normal.
- 3) Check the self-diagnosis switch (Heat source control board SW4 (SW6-10: OFF)).

	Measurement data	Symbol	SW4 setting value
G, GA (Standard / main)	Liquid inlet temperature	TH11	
	Bypass outlet temperature	TH12	
	Bypass inlet temperature	TH15	
	Bypass inlet temperature	TH16	
GB, HB (Sub 1)	Bypass outlet temperature	TH12	
	Bypass inlet temperature	TH15	
GB, HB (Sub 2)	Bypass outlet temperature	TH12	
	Bypass inlet temperature	TH15	

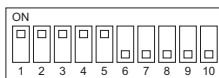

The figure at left shows that the switches 1 through 5 are set to ON and 6 through 10 are set to OFF.

3. Troubleshooting flow chart for LEV Solenoid valve

(1) LEV



Note

1) BC controller: Phenomena when LEV is connected wrongly (reverse connection of LEV1 and LEV3) to the board.

Phenomena			
Cooling-only	Cooling-main	Heating only	Heating main
Non-cooling SH12 small, SC11 small SH16 small, branch pipe SC small BC controller sound	Non-cooling and non-heating SH12 small, SC11 small SH16 large, but branch pipe SC small BC controller sound △PHM large	Indoor heating SC small △ PHM large	Non-cooling Indoor heating SC small △ PHM large

2) Check method of fully open state or fully closed state of LEV

♦Check LEV opening (pulse) on the self-diagnosis LED (Heat source control board SW4 (SW6-10: OFF)).

Full open: 2000 pulses

Fully closed: 110 pulses (In the case of heating-only mode, however, the pulse may become 110 or more.)









♦When LEV is fully open, measure the temperature at the upstream and downstream pipes of LEV, and make sure that there is no temperature difference.

♦When LEV is fully closed, check that there is no refrigerant flowing sound.

3) Refer to the chart below to judge LEV opening controlled by the values of the differential pressure and of the superheat. (BC controller LEV basic operation characteristic)

	Part	Malfunction mode	Operation mode	Content	Standards of judgment on unit stable operation
G, GA type	LEV1	Inclined to close	Heating only Heating-main Cooling-main	Difference between high pressure (P1) and intermediate pressure (P3) is large.	0.3 to 0.4MPa [44 to 58psi]
		Inclined to open		Difference between high pressure (P1) and intermediate pressure (P3) is small.	
	LEV3	Inclined to close	Cooling-only Cooling-main	SH12 is large.	SH12 < 20°C [36°F]
			Heating only Heating-main	Difference between high pressure (P1) and intermediate pressure (P3) is small.	0.3 to 0.4MPa [44 to 58psi]
		Inclined to open	Cooling-only Cooling-main	SC16 and SH12 are small.	SC16 > 3°C [5.4°F] SH12 > 3°C [5.4°F]
			Heating only Heating-main	Difference between high pressure (P1) and intermediate pressure (P3) is large.	0.3 to 0.4MPa [44 to 58psi]
GB, HB type	LEV3	Inclined to close	Cooling-only Cooling-main	SH22 is large.	SH22 < 20°C [36°F]
		Inclined to open	Cooling-only Cooling-main	SH22 is small.	SH22 > 3°C [5.4°F]

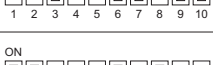
Self-diagnosis LED

	Measurement data	Symbol	SW4 setting value
G, GA (Standard / main)	LEV1 opening	—	
	LEV2 opening	—	
	LEV3 opening	—	
	BC controller bypass outlet superheat	SH12	
	BC controller intermediate part subcool	SC16	
	BC controller liquid-side subcool	SC11	
GB, HB (Sub 1)	LEV3 opening	—	
GB, HB (Sub 2)	LEV3 opening	—	



The figure at left shows that the switches 1 through 5 are set to ON and 6 through 10 are set to OFF.

Troubleshooting flow chart for solenoid valve body

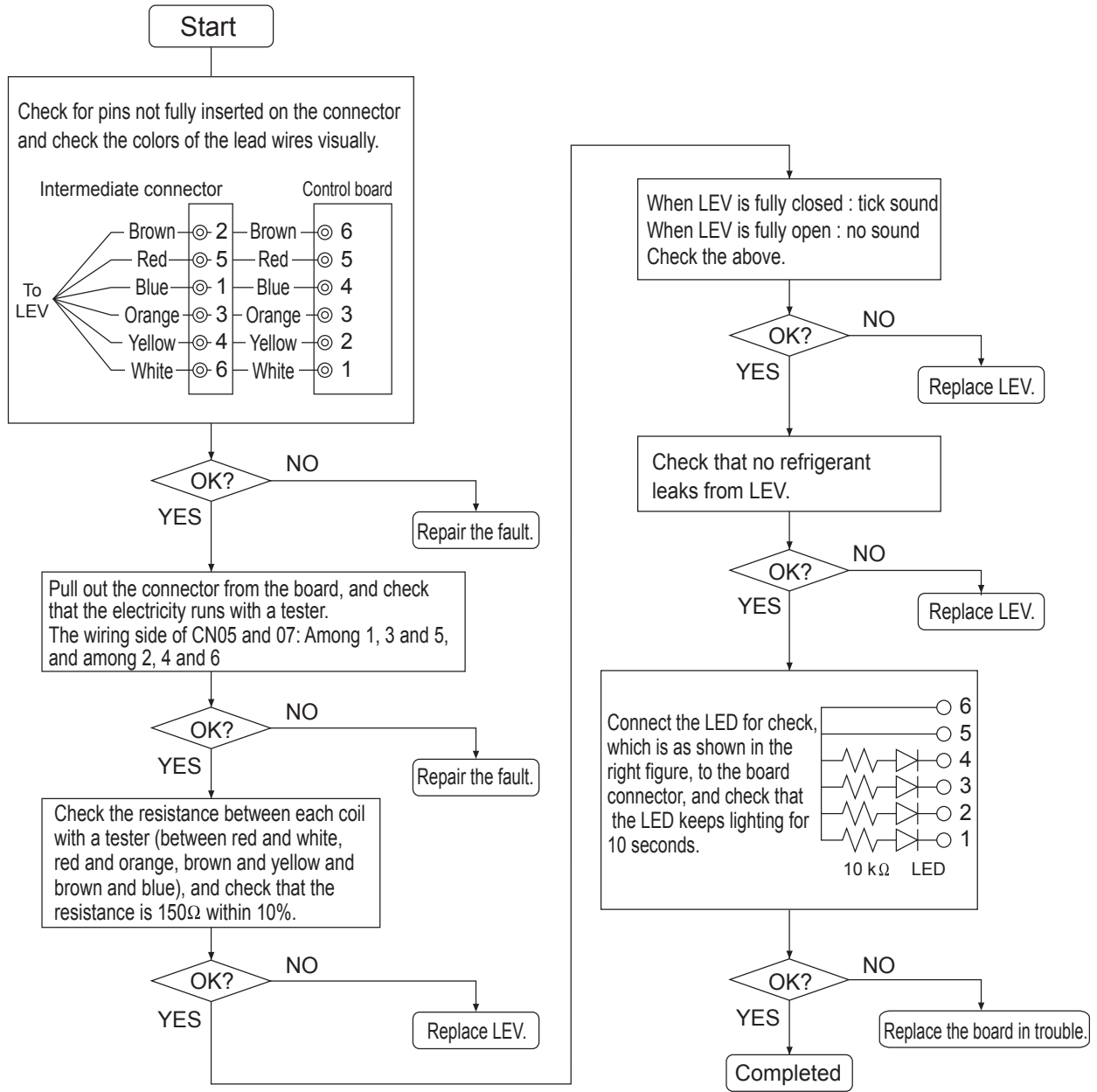

(2) Solenoid valve (SVA, SVB, SVC)

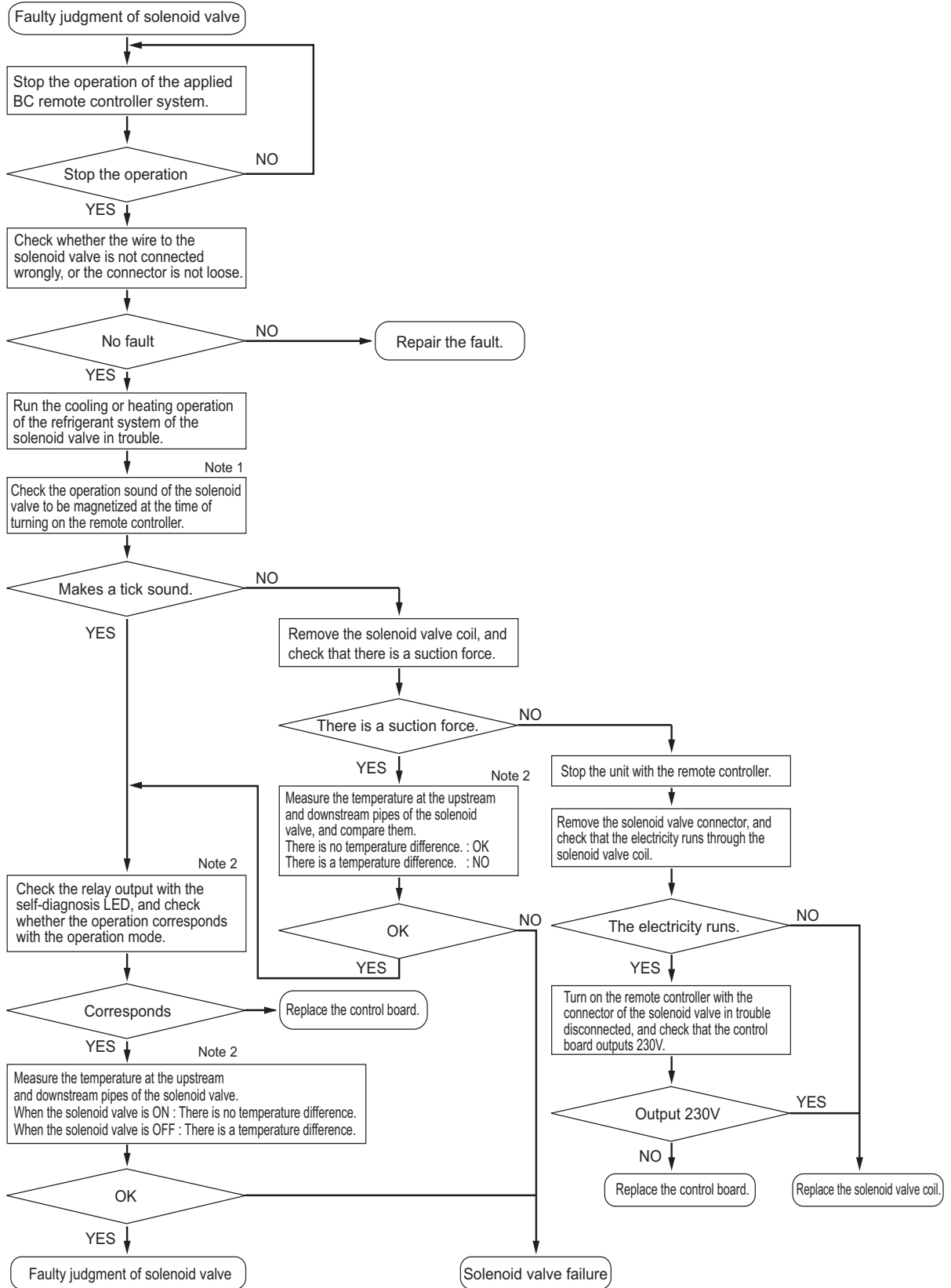

Check whether the BC board output signal corresponds with the solenoid valve operation correspond.

Note

1) SVA, SVB, SVC

SVA, SVB, and SVC turn on or off according to the indoor unit operation mode.

		Mode				
		Cooling	Heating	Stopped	Defrost	Fan
Port	SVA	ON	OFF	OFF	OFF	OFF
	SVB	OFF	ON	OFF	OFF	OFF
	SVC	ON	OFF	OFF	OFF	ON

SVM1, SVM1b, SVM2, SVM2b

SVM1, SVM1b, SVM2, and SVM2b turn on or off according to the indoor unit operation mode.

Operation mode	Cooling only	Cooling main	Heating only	Heating main	Defrost	Stopped
SVM1,SVM1b	ON	Pressure differential control OFF or ON	OFF	OFF	ON	OFF
SVM2, SVM2b	OFF	OFF	Pressure differential control OFF or ON	Pressure differential control OFF or ON	OFF	OFF

Note

2) SVA, SVB, SVC

Measure the temperature at the upstream and downstream pipes ① and ② of SVA.

Measure the temperature at the upstream and downstream ① pipes and ③ of SVB.

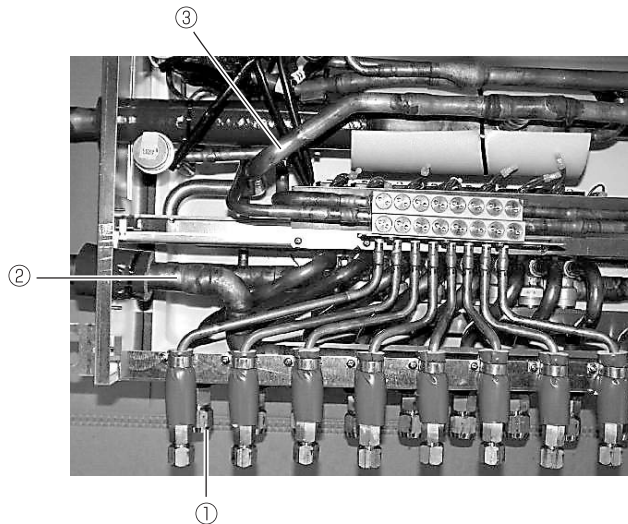

4. BC controller transformer

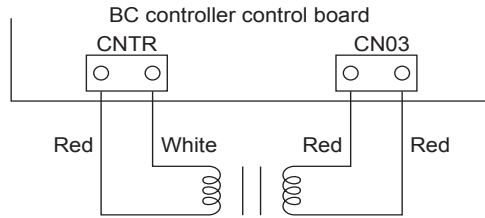

	Normal	Abnormal
CNTR(1)-(3)	about 58 ohm.	Open-phase or shorting
CN03(1)-(3)	about 1.6 ohm.	

* Before measuring the resistance, pull out the connector.

-6- Inverter (TLMU-A1)

- ♦Replace only the compressor if only the compressor is found to be defective. (Overcurrent will flow through the inverter if the compressor is damaged, however, the power supply is automatically cut when overcurrent is detected, protecting the inverter from damage. Make sure that the model selection switches on the outdoor unit (Dip switches SW5-3 through 5-8 on the heat source unit control board) are set correctly. For switch settings, refer to the following page(s). [2] Responding to Error Display on the Remote Controller)
- ♦Replace the defective components if the inverter is found to be defective.
- ♦If both the compressor and the inverter are found to be defective, replace the defective component(s) of both devices.

(1) Inverter-related problems: Troubleshooting and remedies

- 1) The INV board has a large-capacity electrolytic capacitor, in which residual voltage remains even after the main power is turned off, **posing a risk of electric shock**. Before checking the inverter-related components, turn off the power source, leave it turned off for at least 10 minutes, and make sure that the electrolytic capacitor (inverter's main circuit) voltage has dropped to 20 VDC or below. It will take approximately 10 minutes after the power is turned off and before the voltage is discharged.
- 2) The control box contains high-temperature parts. Be careful even after shutting down the power.
- 3) The IPM on the inverter becomes damaged if there are loose screws or connectors. If a problem occurs after replacing some of the parts, mixed up wiring is often the cause of the problem. Check for proper connection of the wiring, screws, connectors, and Faston terminals.
- 4) To avoid damage to the circuit board, do not connect or disconnect the inverter-related connectors with the main power turned on.
- 5) The current sensor will be damaged if a current is passed through without the sensor being connected to the circuit board. Before operating the inverter, be sure to connect the current sensor to the matching connector on the circuit board.
- 6) Faston terminals have a locking function. Make sure the terminals are securely locked in place after insertion.

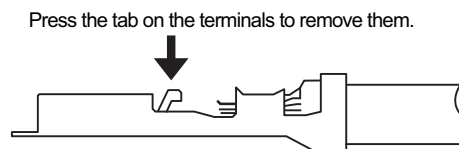

- 7) When the IPM, diode stack, or IGBT is replaced, apply a thin layer of heat radiation grease that is supplied evenly to these parts. Wipe off any grease that may get on the wiring terminal to avoid terminal contact failure.
- 8) Faulty wiring to the compressor damages the compressor. Connect the wiring in the correct phase sequence.
- 9) When the power is turned on, the compressor and the heater are energized even while they are not operating. Before turning on the power, disconnect all power supply wires from the compressor terminal block, and measure the insulation resistance of the compressor. Check the compressor for a ground fault. If the insulation resistance is 1.0 MΩ or below, connect all power supply wires to the compressor or the heater, and turn on the power to the outdoor unit. (The liquid refrigerant in the compressor will evaporate by energizing the compressor.)
- 10) Read Chapter I [13] Precautions for servicing, and tighten screws to the appropriate torque. Loose screws and poor contact can result in overheating and fire.

	Error display/failure condition	Measure/inspection item
[1]	Inverter related errors 4250, 4220, 4230, 4240, 4260, 5301, 0403	Check the details of the inverter error in the error log in X LED Monitor Display on the Heat source Unit Board. Take appropriate measures to the error code and the error details in accordance with IX. [2] Responding to Error Display on the Remote Controller.
[2]	Main power breaker trip	<1> Check the breaker capacity. <2> Check whether the electrical system is short-circuited or ground-faulted. <3> If items cause is not <1> or <2> are not the causes of the problem, see (3)-[1].
[3]	Main power earth leakage breaker trip	<1> Check the earth leakage breaker capacity and the sensitivity current. <2> Meg failure for electrical system other than the inverter <3> If the cause is not <1> or <2>, see (3)-[1].
[4]	Only the compressor does not operate.	Check the inverter frequency on the LED monitor and proceed to (2) - [4] if the compressor is in operation.
[5]	The compressor vibrates violently at all times or makes an abnormal sound.	See (2)-[4].
[6]	Compressor rotation speed does not reach the specified speed.	<1> Check for problems with compressor current and heatsink temperature. <2> Check for imbalance in power supply voltage. *Approximate target: 3% or less.
[7]	Noise is picked up by the peripheral device	<1> Check that power supply wiring of the peripheral device does not run close to the power supply wiring of the heat source unit. <2> Check that the inverter output wiring is not in close contact with the power supply wiring and the transmission lines. <3> Check that the shielded wire is used as the transmission line when it is required, and check that the grounding work is performed properly on the shielded wire. <4> Meg failure for electrical system other than the inverter <5> Attach a ferrite core to the inverter output wiring. (Contact the factory for details of the service part settings.) <6> Provide separate power supply to the air conditioner and other electric appliances. <7> If the error occurred suddenly, a ground fault of the inverter output can be considered. See (2)-[4]. *Contact the factory for cases other than those listed above.
[8]	Sudden malfunction (as a result of external noise.)	<1> Check that the grounding work is performed properly. <2> Check that the shielded wire is used as the transmission line when it is required, and check that the grounding work is performed properly on the shielded wire. <3> Check that neither the transmission line nor the external connection wiring does not run close to another power supply system or does not run through the same conduit pipe. * Contact the factory for cases other than those listed above.

(2) Inverter output related troubles

	Items to be checked	Phenomena	Remedy
[1] Check the INV board error detection circuit.	<P72, P96, P120, P216, P240 models> (1) Remove power supply. (2) Disconnect the inverter output wire from the terminals of the INV board (SC-U, SC-V, SC-W). (3) Apply power supply. (4) Put the outdoor unit into operation.	1) IPM/overcurrent breaker trip Error code: 4250 Detail code: No. 101, 104, 105, 106, 107, and 128	Replace the INV board.
		2) Logic error Error code: 4220 Detail code: No. 111	Replace the INV board.
		3) ACCT sensor circuit failure Error code: 5301 Detail code: No.117, 127	Replace the INV board.
		4) IPM open Error code: 5301 Detail code: No.119	Normal
	<P144, P168, P192 models> (1) Remove power supply. (2) Disconnect the inverter output wire from the output terminals (U, V, W) of the IPM. (3) Apply power supply. (4) Put the outdoor unit into operation.	1) IPM/overcurrent breaker trip Error code: 4250 Detail code: No. 101, 103, 104, 105, 106, and 107	Refer to IX [4] -6- (7). Replace the IPM, and put the outdoor unit back into operation. If the problem persists, replace the INV board.
		2) Logic error Error code: 4220 Detail code: No. 111	Refer to IX [4] -6- (7). Replace the IPM, and put the outdoor unit back into operation. If the problem persists, replace the INV board. Replace the INV board, and put the outdoor unit back into operation. If the problem persists, replace the DCCT.
		3) ACCT sensor circuit failure Error code: 5301 Detail code: No.117	Replace the INV board.
		4) DCCT sensor circuit failure Error code: 5301 Detail code: No.118	Replace the DCCT board. Replace the DCCT, and put the outdoor unit back into operation. If the problem persists, replace the INV board.
		5) IPM open Error code: 5301 Detail code: No.119	Normal
[2] Check for compressor ground fault or coil error.	Disconnect the compressor wiring, and check the compressor Meg, and coil resistance.	1) Compressor Meg failure Error if less than 1 Mohm. When no liquid refrigerant in the compressor	Check that no liquid refrigerant is present in the compressor, and replace the compressor.
		2) <P72, P96, P120 models> Coil resistance value of 0.20 ohm <P144, P168, P192 models> Coil resistance value of 0.088 ohm <P216, P240 models> Coil resistance value of 0.179 ohm	Replace the compressor.

	Items to be checked	Phenomena	Remedy
<p>[3] Check whether the inverter is damaged. (No load)</p>	<P72, P96, P120, P216, P240 models>	1) Inverter-related problems are detected.	Turn off SW1-1 on the INV board and go to section [1].
	(1) Remove power supply.	2) Inverter voltage is not output.	Replace the INV board.
	(2) Disconnect the inverter output wire from the terminals of the INV board (SC-U, SC-V, SC-W).	3) There is an voltage imbalance between the wires. Greater than 5% imbalance or 5V	Replace the INV board.
	(3) Turn on SW1-1 on the INV board.	4) There is no voltage imbalance between the wires.	Normal *Turn off SW1-1 on the INV board.
	(4) Apply power supply.		
	(5) Put the outdoor unit into operation. Check the inverter output voltage after the inverter output frequency has stabilized.		
	<P144, P168, P192 models>	1) Inverter-related problems are detected.	Turn off SW1-1 on the INV board and go to section [1].
	(1) Remove power supply.	2) Inverter voltage is not output.	Check the connection between the IPM and the CNIPM on the INV board. There is no problem, replace the IPM. If the problem persists, replace the INV board.
(2) Disconnect the inverter output wire from the output terminals (U, V, W) of the IPM.	3) There is an voltage imbalance between the wires. Greater than 5% imbalance or 5V	Replace the IPM. If the problem persists, replace the INV board.	
(3) Turn on SW1-1 on the INV board.	4) There is no voltage imbalance between the wires.	Normal *Turn off SW1-1 on the INV board.	
(4) Apply power supply.			
(5) Put the outdoor unit into operation.			

	Items to be checked	Phenomena	Remedy
<p>[4] Check whether the inverter is damaged. (During compressor operation)</p>	<p>Put the outdoor unit into operation. Check the inverter output voltage after the inverter output frequency has stabilized.</p>	<p>1) Overcurrent-related problems occur immediately after compressor startup. (4250 Details : No.101, 103, 106, 107)</p>	<p>a. Check items [1] through [2] for problems.</p> <p>b. Check that high and low pressures are balanced.</p> <p>c. Check that no liquid refrigerant is present in the compressor. ->Go to "d." when the problem persists after compressor startup was repeated several times. If normal operation is restored, check the belt heater for problems.</p> <p>d. Check that there is a pressure difference between high and low pressures after compressor startup. ->Check the high pressure with LED monitor for changes. Replace the compressor if there is no pressure difference. (the compressor may be locked.)</p>
		<p>2) There is a voltage imbalance between the wires after the inverter output voltage is stabilized. Greater than the larger of the following values: imbalance of 5% or 5V</p>	<p>If there is a voltage imbalance <P72, P96, P120, P216, P240 models> Replace the INV board. <P144, P168, P192 models> Replace the IPM. If the problem persists, replace the INV board. If the problem persists after replacing the above parts, go to section [2]. Check the belt heater for problems if there is no voltage imbalance. ->When the error occurred, liquid refrigerant may have been present in the compressor.</p>
	<P216, 240 models>	<p>3) An overcurrent error is detected immediately after the compressor is started up or during operation Check code: 4220 Detail code: 124</p>	<p>a. Check that a voltage of 12 DC is supplied to the relay at startup. Across connector pins 1 (+) and 2 (-) on the CNRY2 connector.</p> <p>b. Replace the inverter board if no problems are found with item a.</p>
		<p>4) Electrical current overload error during operation Check code: 4250 Detail code: 121, 122</p>	<p>Go to [5]</p>
		<p>5) An overcurrent error occurs immediately after the compressor starts up or during operation. Check code: 4250 Detail code: 101, 106, 107, 128</p>	<p>a. Check for compressor flooding and refrigerant floodback.</p> <p>b. Check for an imbalance in the phase voltages.</p> <p>c. Replace the inverter board if no problems are found with item a or b.</p> <p>d. Go to item [2] if the problem persists after replacement.</p>
		<p>6) Voltage overload error Check code: 4220 Detail code: 109, 110, 112</p>	<p>Normal. Go to [5]</p>
		<p>7) No problems are found with items 1) through 6).</p>	<p>Normal. Go to [5]</p>

	Items to be checked	Phenomena	Remedy
[5] Check the converter for damage (with the compressor in operation). (P216, P240 models only)	(1) Operate the heat-source unit.	1) BUS voltage does not rise (change) BUS voltage does not rise to a level between 330 and 380 VDC, or the following error is detected. Check code: 4220 Detail code: 123	Replace the INV board.
	(2) Check the BUS voltage after the converter circuit starts up and the BUS voltage has risen. *BUS voltage rises at the fan speed of approximately 60 rps depending on the power supply voltage.	2) An overcurrent error occurs after the converter circuit starts up. Check code: 4250 Detail code: 121, 122	a. Replace the INV board if the same error occurs after restart. b. Replace DCL if the problem persists after replacement.
		3) Voltage overload error occurs after the converter circuit starts up. Check code: 4220 Detail code: 109, 110, 112	a. Replace the INV board if the same error occurs after restart. b. Replace DCL if the problem persists after replacement.
		4) No problems are found with items 1) through 3).	Normal

(3) Trouble treatment when the main power breaker is tripped.

	Items to be checked	Phenomena	Remedy
[1]	Perform Meg check between the terminals on the power terminal block TB1.	Zero to several ohm, or Meg failure	Check each part in the main inverter circuit. *Refer to "Simple checking procedures for individual components of main inverter circuit". •IGBT module •IPM •Rush current protection resistor •Electromagnetic relay •DC reactor
[2]	Turn on the power again and check again.	1) Main power breaker trip 2) No remote control display	
[3]	Turn on the heat source unit and check that it operates normally.	1) Operates normally without tripping the main breaker.	a) The wiring may have been short-circuited. Search for the wire that short-circuited, and repair it. b) If item a) above is not the cause of the problem, the compressor may have a problem.
		2) Main power breaker trip	A compressor ground fault can be considered. Go to (2)-[2].

(4) Trouble treatment when the main power earth leakage breaker is tripped

	Items to be checked	Phenomena	Remedy
[1]	Check the earth leakage breaker capacity and the sensitivity current.	Use of a non-specified earth leakage breaker	Replace with a regulation earth leakage breaker.
[2]	Check the resistance at the power supply terminal block with a megger.	Failure resistance value	Check each part and wiring. *Refer to (5) "Simple checking procedures for individual components of main inverter circuit". •IGBT module •Rush current protection resistor •Electromagnetic relay •DC reactor
[3]	Disconnect the compressor wirings and check the resistance of the compressor with a megger.	Failure compressor if the insulating resistance value is not in specified range. Failure when the insulating resistance value is 1 Mohm or less.	Check that there is no liquid refrigerant in the compressor. If there is none, replace the compressor.

Note

The insulation resistance could go down to close to 1Mohm after installation or when the power is kept off for an extended period of time because of the accumulation of refrigerant in the compressor. If the earth leakage breaker is triggered, please use the following procedure to take care of this.

- Disconnect the wires from the compressor's terminal block.
- If the resistance is less than 1 Mohm, switch on the power for the heat source unit with the wires still disconnected.
- Leave the power on for at least 12 hours.
- Check that the resistance has recovered to 1 Mohm or greater.

Earth leakage current measurement method

- For easy on-site measurement of the earth leakage current, enable the filter with a measurement instrument that has filter functions as below, clamp all the power supply wires, and measure.
Recommended measurement instrument: CLAMP ON LEAK HiTESTER 3283 made by HIOKI E.E. CORPORATION
- When measuring one device alone, measure near the device's power supply terminal block.

(5) Simple checking procedure for individual components of main inverter circuit

Note

Before checking the main INV circuit, turn off the power source, leave it turned off for at least 10 minutes, make sure that the electrolytic capacitor (inverter's main circuit) voltage has dropped to 20 VDC or below, and then remove the relevant components from the control box.

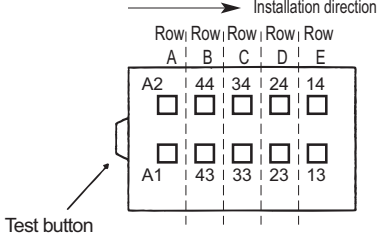
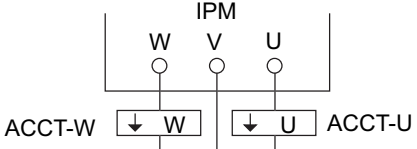
Part name	Judgment method																																	
IGBT module	Refer to IX [4] -6- (6).																																	
Diode stack	Refer to IX [4] -6- (8).																																	
IPM (Intelligent power module)	Refer to IX [4] -6- (7).																																	
Rush current protection resistor R1	Measure the resistance between terminals: $22 \Omega \pm 10\%$																																	
Electromagnetic relay 72C	<p><P216, P240 models> Inverter board RY1-RY4</p> <table border="1"> <thead> <tr> <th></th> <th>Check point</th> <th>Checking criteria</th> </tr> </thead> <tbody> <tr> <td>Coil RY1</td> <td>Between 1-2 pins and inverter boards CNRY</td> <td>$160\Omega \pm 10\%$</td> </tr> <tr> <td>Contact RY1</td> <td>Between 3-4 pins and inverter boards CNRY</td> <td>Inverter board CNRY Open: ∞ Inverter board CNRY When 12 VDC is being input: 0Ω</td> </tr> <tr> <td>Coil RY2-RY4</td> <td>Between 1-2 pins and inverter boards CNRY2</td> <td>$53\Omega \pm 10\%$</td> </tr> <tr> <td>Contact RY2-RY4</td> <td>Inverter board FT-R 21 and FT-R 22 *Faston terminal wiring removed</td> <td>Inverter board CNRY2 Open: ∞ Inverter board CNRY2 When 12 VDC is being input: 0Ω</td> </tr> </tbody> </table>  <p><P72, P96, P120, P144, P168, P192 models> Noise filter X001</p> <p>Note This electromagnetic relay is rated at 200VAC and is driven by a coil. The resistance between the coils in row A cannot be measured with a tester. Check only for shorting.</p> <p><P72, P96, P120 models></p> <table border="1"> <thead> <tr> <th></th> <th>Check point</th> <th>Checking criteria</th> </tr> </thead> <tbody> <tr> <td>Coil</td> <td>Row A</td> <td>Not to be short-circuited</td> </tr> <tr> <td>Contact</td> <td>Row B to Row E</td> <td>With the test button turned off : ∞ With the test button turned on : 0Ω</td> </tr> </tbody> </table>  <p><P144, P168, P192 models></p> <table border="1"> <thead> <tr> <th></th> <th>Check point</th> <th>Checking criteria</th> </tr> </thead> <tbody> <tr> <td>Coil</td> <td>Between No. 1 pin and No. 3 pin of the CN03 on the noise filter board</td> <td>Not to be short-circuited</td> </tr> <tr> <td>Contact</td> <td>+ terminal on the diode stack and terminal TB31 on the noise filter</td> <td>With the test button turned off : $22\Omega \pm 10\%$ With the test button turned on : 0Ω</td> </tr> </tbody> </table>		Check point	Checking criteria	Coil RY1	Between 1-2 pins and inverter boards CNRY	$160\Omega \pm 10\%$	Contact RY1	Between 3-4 pins and inverter boards CNRY	Inverter board CNRY Open: ∞ Inverter board CNRY When 12 VDC is being input: 0Ω	Coil RY2-RY4	Between 1-2 pins and inverter boards CNRY2	$53\Omega \pm 10\%$	Contact RY2-RY4	Inverter board FT-R 21 and FT-R 22 *Faston terminal wiring removed	Inverter board CNRY2 Open: ∞ Inverter board CNRY2 When 12 VDC is being input: 0Ω		Check point	Checking criteria	Coil	Row A	Not to be short-circuited	Contact	Row B to Row E	With the test button turned off : ∞ With the test button turned on : 0Ω		Check point	Checking criteria	Coil	Between No. 1 pin and No. 3 pin of the CN03 on the noise filter board	Not to be short-circuited	Contact	+ terminal on the diode stack and terminal TB31 on the noise filter	With the test button turned off : $22\Omega \pm 10\%$ With the test button turned on : 0Ω
	Check point	Checking criteria																																
Coil RY1	Between 1-2 pins and inverter boards CNRY	$160\Omega \pm 10\%$																																
Contact RY1	Between 3-4 pins and inverter boards CNRY	Inverter board CNRY Open: ∞ Inverter board CNRY When 12 VDC is being input: 0Ω																																
Coil RY2-RY4	Between 1-2 pins and inverter boards CNRY2	$53\Omega \pm 10\%$																																
Contact RY2-RY4	Inverter board FT-R 21 and FT-R 22 *Faston terminal wiring removed	Inverter board CNRY2 Open: ∞ Inverter board CNRY2 When 12 VDC is being input: 0Ω																																
	Check point	Checking criteria																																
Coil	Row A	Not to be short-circuited																																
Contact	Row B to Row E	With the test button turned off : ∞ With the test button turned on : 0Ω																																
	Check point	Checking criteria																																
Coil	Between No. 1 pin and No. 3 pin of the CN03 on the noise filter board	Not to be short-circuited																																
Contact	+ terminal on the diode stack and terminal TB31 on the noise filter	With the test button turned off : $22\Omega \pm 10\%$ With the test button turned on : 0Ω																																
DC reactor DCL	Measure the resistance between terminals: 1Ω or lower (almost 0Ω) Measure the resistance between terminals and the chassis: ∞																																	
Current sensor ACCT	<p><P144, P168, P192 models> Disconnect the CNCT2 connector and measure the resistance between terminals: $280 \Omega \pm 30 \Omega$ 1 - 2 PIN (U-phase), 3 - 4 PIN (W-phase)</p>  <p>*Check the ACCT connection phase and the direction of the connection</p>																																	

(6) Troubleshooting Problems with IGBT Module

(P72, P96, P120, P216, P240 models)

Measure the resistances between each pair of terminals on the IGBT with a tester, and use the results for troubleshooting. The terminals on the INV board are used for the measurement.

1) Notes on measurement

- ◆Check the polarity before measuring. (On the tester, black normally indicates plus.)
- ◆Check that the resistance is not open ($\infty \Omega$) or not shorted (to 0Ω).
- ◆The values are for reference, and the margin of errors is allowed.
- ◆The result that is more than double or half of the result that is measured at the same measurement point is not allowed.
- ◆Disconnect all the wiring connected the INV board, and make the measurement.

2) Tester restriction

- ◆Use the tester whose internal electrical power source is 1.5V or greater
- ◆Use the dry-battery-powered tester.

Note

(The accurate diode-specific resistance cannot be measured with the button-battery-powered card tester, as the applied voltage is low.)

- ◆Use a low-range tester if possible. A more accurate resistance can be measured.

Judgment value (reference)

		Black (+)				
		SC-P1	TB-N	SC-R	SC-S	SC-T
Red (-)	SC-P1	-	-	5 - 200 Ω	5 - 200 Ω	5 - 200 Ω
	TB-N	-	-	∞	∞	∞
	SC-R	∞	5 - 200 Ω	-	-	-
	SC-S	∞	5 - 200 Ω	-	-	-
	SC-T	∞	5 - 200 Ω	-	-	-

		Black (+)				
		SC-P2	TB-N	SC-U	SC-V	SC-W
Red (-)	SC-P2	-	-	5 - 200 Ω	5 - 200 Ω	5 - 200 Ω
	TB-N	-	-	∞	∞	∞
	SC-U	∞	5 - 200 Ω	-	-	-
	SC-V	∞	5 - 200 Ω	-	-	-
	SC-W	∞	5 - 200 Ω	-	-	-

INV board external diagram

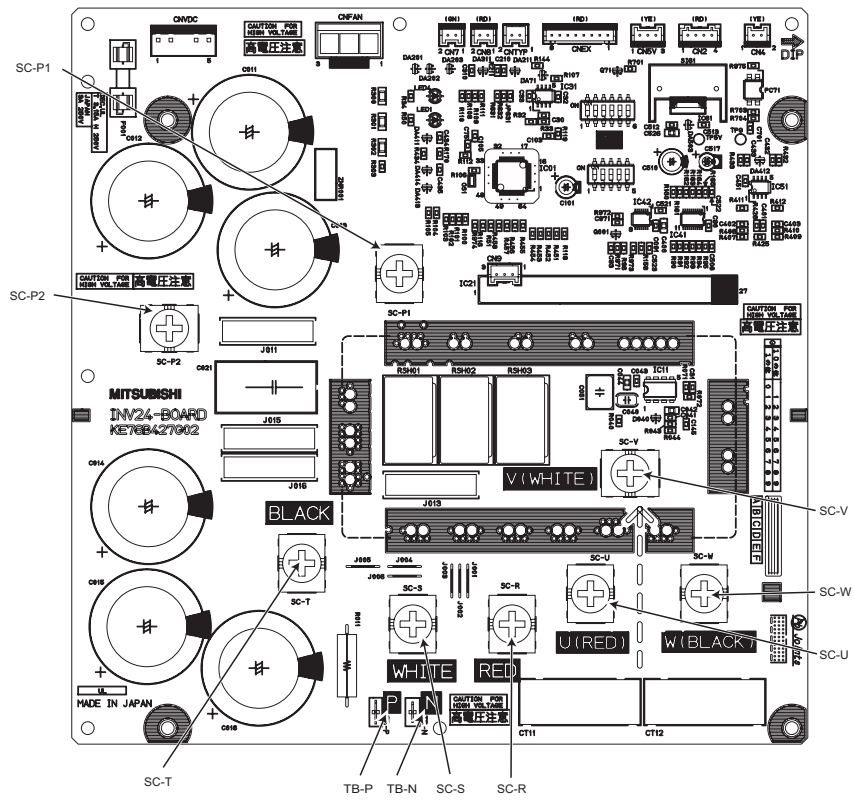

(P216, P240 models)

Measure the resistances between each pair of terminals on the IGBT with a tester, and use the results for troubleshooting. The terminals on the INV board are used for the measurement.

1) Notes on measurement

- ♦Check the polarity before measuring. (On the tester, black normally indicates plus.)
- ♦Check that the resistance is not open ($\infty \Omega$) or not shorted (to 0Ω).
- ♦The values are for reference, and the margin of errors is allowed.
- ♦The result that is more than double or half of the result that is measured at the same measurement point is not allowed.
- ♦Disconnect all the wiring connected the INV board, and make the measurement.

2) Tester restriction

- ♦Use the tester whose internal electrical power source is 1.5V or greater
- ♦Use the dry-battery-powered tester.

Note

(The accurate diode-specific resistance cannot be measured with the button-battery-powered card tester, as the applied voltage is low.)

- ♦Use a low-range tester if possible. A more accurate resistance can be measured.

Judgment value (reference)

		Black (+)						
		R	S	T	SC-B	SC-L	FT-R21	SC-N1
Red (-)	R	-	-	-	-	∞	-	5 - 200 Ω
	S	-	-	-	-	∞	-	5 - 200 Ω
	T	-	-	-	-	∞	-	5 - 200 Ω
	SC-B	-	-	-	-	-	∞	-
	SC-L	5 - 200 Ω	5 - 200 Ω	5 - 200 Ω	-	-	-	-
	FT-R21	-	-	-	5 - 200 Ω	-	-	-
	SC-N1	∞	∞	∞	-	-	-	-

		Black (+)				
		FT-R21	SC-N2	SC-U	SC-V	SC-W
Red (-)	FT-R21	-	-	5 - 200 Ω	5 - 200 Ω	5 - 200 Ω
	SC-N2	-	-	∞	∞	∞
	SC-U	∞	5 - 200 Ω	-	-	-
	SC-V	∞	5 - 200 Ω	-	-	-
	SC-W	∞	5 - 200 Ω	-	-	-

INV board external diagram

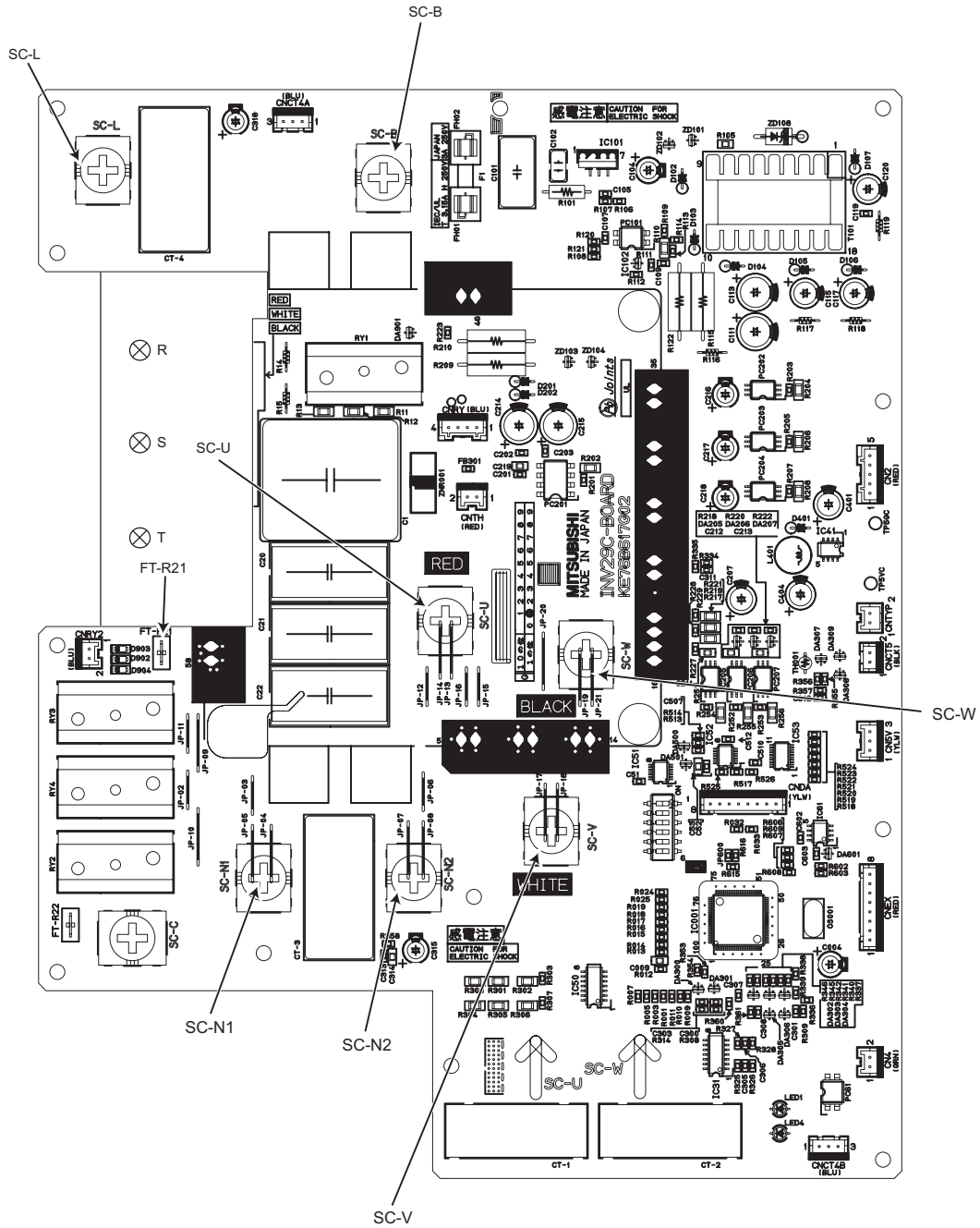

(7) Troubleshooting Problems with IPM (P144, P168, P192 models)

Measure resistances between each pair of terminals on the IPM with a tester, and use the results for troubleshooting.

1) Notes on measurement

- ♦ Check the polarity before measuring. (On the tester, black normally indicates plus.)
- ♦ Check that the resistance is not open ($\infty \Omega$) or not shorted (to 0Ω).
- ♦ The values are for reference, and the margin of errors is allowed.
- ♦ The result that is more than double or half of the result that is measured at the same measurement point is not allowed.

2) Tester restriction

- ♦ Use the tester whose internal electrical power source is 1.5V or greater
- ♦ Use the dry-battery-powered tester.

Note

(The accurate diode-specific resistance cannot be measured with the button-battery-powered card tester, as the applied voltage is low.)

- ♦ Use a low-range tester if possible. A more accurate resistance can be measured.

Judgment value (reference)

		Black (+)				
		P	N	U	V	W
Red (-)	P	-	-	5 - 200 Ω	5 - 200 Ω	5 - 200 Ω
	N	-	-	∞	∞	∞
	U	∞	5 - 200 Ω	-	-	-
	V	∞	5 - 200 Ω	-	-	-
	W	∞	5 - 200 Ω	-	-	-

External view

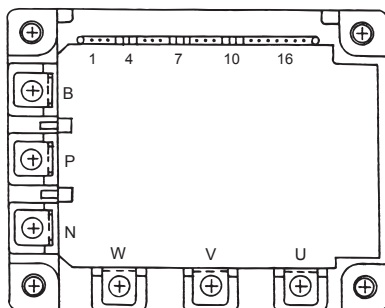

Internal circuit diagram

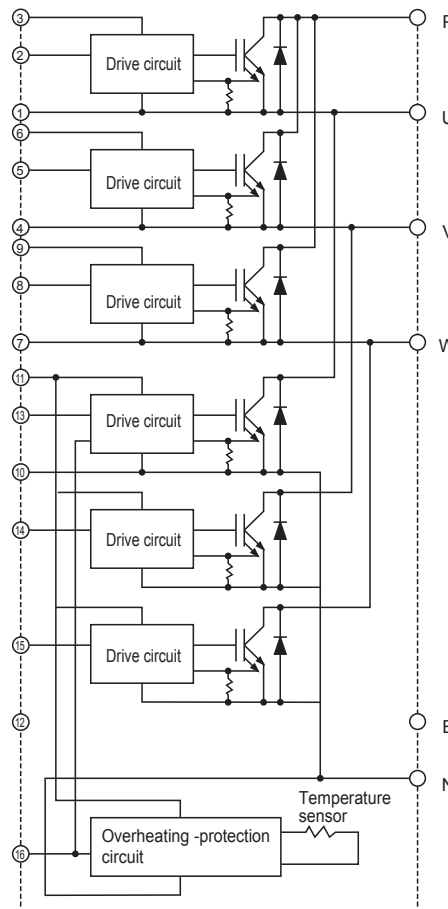

(8) Troubleshooting Problems with diode stack (P144, P168, P192 models)

Measure resistances between each pair of terminals on the diode stack with a tester, and use the results for troubleshooting. For cautionary notes on measuring diode stack resistance and information on the types of testers to be used, refer to the following page(s). IX [4] Troubleshooting Principal Parts

Judgment value (reference)

		Black (+)				
		+ (P)	- (N)	to (L1)	to (L2)	to (L3)
Red (-)	+ (P)	-	-	5 - 200 Ω	5 - 200 Ω	5 - 200 Ω
	- (N)	-	-	∞	∞	∞
	to (L1)	∞	5 - 200 Ω	-	-	-
	to (L2)	∞	5 - 200 Ω	-	-	-
	to (L3)	∞	5 - 200 Ω	-	-	-

External view

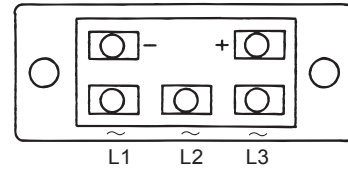

Internal circuit diagram

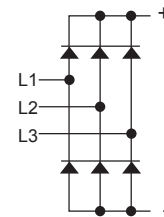

-6- Inverter (YLMU-A1)

- Replace only the compressor if only the compressor is found to be defective.(Overcurrent will flow through the inverter if the compressor is damaged, however, the power supply is automatically cut when overcurrent is detected, protecting the inverter from damage. Make sure that the model selection switches on the outdoor unit (Dip switches SW5-3 through 5-8 on the heat source unit control board) are set correctly. For switch settings, refer to the following page(s). [2] Responding to Error Display on the Remote Controller)
- Replace the defective components if the inverter is found to be defective.
- If both the compressor and the inverter are found to be defective, replace the defective component(s) of both devices.

(1) Inverter-related problems: Troubleshooting and remedies

- 1) The INV board has a large-capacity electrolytic capacitor, in which residual voltage remains even after the main power is turned off, **posing a risk of electric shock**. Before checking the inverter-related components, turn off the power source, leave it turned off for at least 10 minutes, and make sure that the electrolytic capacitor (inverter's main circuit) voltage has dropped to 20 VDC or below. It will take approximately 10 minutes after the power is turned off and before the voltage is discharged.
- 2) The control box contains high-temperature parts. Be careful even after shutting down the power.
- 3) The IPM on the inverter becomes damaged if there are loose screws or connectors. If a problem occurs after replacing some of the parts, mixed up wiring is often the cause of the problem. Check for proper connection of the wiring, screws, connectors, and Faston terminals.
- 4) To avoid damage to the circuit board, do not connect or disconnect the inverter-related connectors with the main power turned on.
- 5) Faston terminals have a locking function. Make sure the terminals are securely locked in place after insertion.

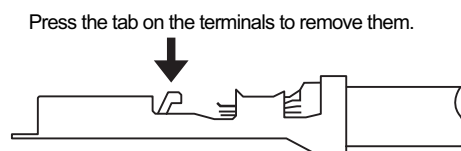

- 6) When the IPM or IGBT is replaced, apply a thin layer of heat radiation grease that is supplied evenly to these parts. Wipe off any grease that may get on the wiring terminal to avoid terminal contact failure.
- 7) Faulty wiring to the compressor damages the compressor. Connect the wiring in the correct phase sequence.
- 8) When the power is turned on, the compressor and the heater are energized even while they are not operating. Before turning on the power, disconnect all power supply wires from the compressor terminal block, and measure the insulation resistance of the compressor. Check the compressor for a ground fault. If the insulation resistance is 1.0 MΩ or below, connect all power supply wires to the compressor or the heater, and turn on the power to the outdoor unit. (The liquid refrigerant in the compressor will evaporate by energizing the compressor.)
- 9) Read Chapter I [13] Precautions for servicing, and tighten screws to the appropriate torque. Loose screws and poor contact can result in overheating and fire.

	Error display/failure condition	Measure/inspection item
[1]	Inverter related errors 4250, 4220, 4230, 4240, 4260, 5301, 0403	Check the details of the inverter error in the error log in X LED Monitor Display on the Heat source Unit Board. Take appropriate measures to the error code and the error details in accordance with IX. [2] Responding to Error Display on the Remote Controller.
[2]	Main power breaker trip	<1> Check the breaker capacity. <2> Check whether the electrical system is short-circuited or ground-faulted. <3> If items cause is not <1> or <2> are not the causes of the problem, see (3)-[1].
[3]	Main power earth leakage breaker trip	<1> Check the earth leakage breaker capacity and the sensitivity current. <2> Meg failure for electrical system other than the inverter <3> If the cause is not <1> or <2>, see (3)-[1].
[4]	Only the compressor does not operate.	Check the inverter frequency on the LED monitor and proceed to (2) - [4] if the compressor is in operation.
[5]	The compressor vibrates violently at all times or makes an abnormal sound.	See (2)-[4].
[6]	Compressor rotation speed does not reach the specified speed.	<1> Check for problems with compressor current and heatsink temperature. <2> Check for imbalance in power supply voltage. *Approximate target: 3% or less.
[7]	Noise is picked up by the peripheral device	<1> Check that power supply wiring of the peripheral device does not run close to the power supply wiring of the heat source unit. <2> Check if the inverter output wiring is not running parallel to the power supply wiring and the transmission lines. <3> Check that the shielded wire is used as the transmission line when it is required, and check that the grounding work is performed properly on the shielded wire. <4> Meg failure for electrical system other than the inverter <5> Attach a ferrite core to the inverter output wiring. (Contact the factory for details of the service part settings.) <6> Provide separate power supply to the air conditioner and other electric appliances. <7> If the error occurred suddenly, a ground fault of the inverter output can be considered. See (2)-[4]. *Contact the factory for cases other than those listed above.
[8]	Sudden malfunction (as a result of external noise.)	<1> Check that the grounding work is performed properly. <2> Check that the shielded wire is used as the transmission line when it is required, and check that the grounding work is performed properly on the shielded wire. <3> Check that neither the transmission line nor the external connection wiring does not run close to another power supply system or does not run through the same conduit pipe. * Contact the factory for cases other than those listed above.

(2) Inverter output related troubles

	Items to be checked	Phenomena	Remedy
[1] Check the INV board error detection circuit.	(1) Turn off the power.	1) Overcurrent error Error code: 4250 Detail code: No. 101, 104, 105, 106, and 107	Replace the INV board.
	(2) Disconnect the inverter output wire from the terminals of the INV board (SC-U, SC-V, SC-W).	2) Logic error Error code: 4220 Detail code: No. 111	Replace the INV board.
	(3) Turn on the power.	3) ACCT sensor circuit failure Error code: 5301 Detail code: No.117	Replace the INV board.
	(4) Put the heat source unit into operation.	4) IPM open Error code: 5301 Detail code: No.119	Normal
[2] Check for compressor ground fault or coil error.	Disconnect the compressor wiring, and check the compressor Meg, and coil resistance.	1) Compressor Meg failure Error if less than 1 Mohm.	Check that there is no liquid refrigerant in the compressor. If there is none, replace the compressor.
		2) Compressor coil resistance failure <P72, P96, P120 models> Coil resistance value of 0.71 ohm <P144, P168, P192 models> Coil resistance value of 0.30 ohm <P216, P240 models> Coil resistance value of 0.611 ohm	Replace the compressor.
[3] Check whether the inverter is damaged. (No load)	(1) Turn off the power.	1) Inverter-related problems are detected.	Connect the short-circuit connector to CN6, and go to section [1].
	(2) Disconnect the inverter output wire from the terminals of the INV board (SC-U, SC-V, SC-W).	2) Inverter voltage is not output at the terminals (SC-U, SC-V, and SC-W)	Replace the INV board.
	(3) Disconnect the short-circuit connector from CN6 on the INV board.	3) There is a voltage imbalance between the wires. Greater than 5% imbalance or 5V	Replace the INV board.
	(4) Turn on the power.	4) There is no voltage imbalance between the wires.	Normal *Reconnect the short-circuit connector to CN6 after checking the voltage.
	(5) Put the heat source unit into operation. Check the inverter output voltage after the inverter output frequency has stabilized.		
[4] Check whether the inverter is damaged. (During compressor operation)	Put the heat source unit into operation. Check the inverter output voltage after the inverter output frequency has stabilized.	1) An overcurrent error is detected immediately after the compressor is started up or during operation. Error code: 4250 Detail code: No.101, 103, 106, 107	a) Check items [1] through [3] for problems. b) Check that high and low pressures are balanced. c) Check for compressor flooding and refrigerant flood back. ->If the problem persists after restarting the unit several times, see item "d" d) Check that there is a pressure difference between high and low pressures after compressor startup. ->Check the high pressure with LED monitor for changes. Replace the compressor if there is no pressure difference. (the compressor may be locked.)
		2) There is a voltage imbalance between the wires. Greater than 5% imbalance or 5V	Replace the INV board.

(3) Trouble treatment when the main power breaker is tripped

	Items to be checked	Phenomena	Remedy
[1]	Check the breaker capacity.	Use of a non-specified breaker	Replace it with a specified breaker.
[2]	Perform Meg check between the terminals on the power terminal block TB1.	Zero to several ohm, or Meg failure	Check each part and wiring. *Refer to (5) "Simple checking procedures for individual components of main inverter circuit". •IGBT module •Rush current protection resistor •Electromagnetic relay •DC reactor
[3]	Turn on the power again and check again.	1) Main power breaker trip 2) No remote control display	
[4]	Turn on the heat source unit and check that it operates normally.	1) Operates normally without tripping the main breaker. 2) Main power breaker trip	a) The wiring may have been short-circuited. Search for the wire that short-circuited, and repair it. b) If item a) above is not the cause of the problem, refer to (2)-[1]-[4].

(4) Trouble treatment when the main power earth leakage breaker is tripped

	Items to be checked	Phenomena	Remedy
[1]	Check the earth leakage breaker capacity and the sensitivity current.	Use of a non-specified earth leakage breaker	Replace with a regulation earth leakage breaker.
[2]	Check the resistance at the power supply terminal block with a megger.	Failure resistance value	Check each part and wiring. *Refer to (5) "Simple checking procedures for individual components of main inverter circuit". •IGBT module •Rush current protection resistor •Electromagnetic relay •DC reactor
[3]	Disconnect the compressor wirings and check the resistance of the compressor with a megger.	Failure compressor if the insulating resistance value is not in specified range. Failure when the insulating resistance value is 1 Mohm or less.	Check that there is no liquid refrigerant in the compressor. If there is none, replace the compressor.

Note

The insulation resistance could go down to close to 1Mohm after installation or when the power is kept off for an extended period of time because of the accumulation of refrigerant in the compressor. If the earth leakage breaker is triggered, please use the following procedure to take care of this.

- Disconnect the wires from the compressor's terminal block.
- If the resistance is less than 1 Mohm, switch on the power for the heat source unit with the wires still disconnected.
- Leave the power on for at least 12 hours.
- Check that the resistance has recovered to 1 Mohm or greater.

Earth leakage current measurement method

- For easy on-site measurement of the earth leakage current, enable the filter with a measurement instrument that has filter functions as below, clamp all the power supply wires, and measure.
Recommended measurement instrument: CLAMP ON LEAK HiTESTER 3283 made by HIOKI E.E. CORPORATION
- When measuring one device alone, measure near the device's power supply terminal block.

(5) Simple checking procedure for individual components of main inverter circuit

Note

Before inspecting the inside of the control box, turn off the power, keep the unit off for at least 10 minutes, and confirm that the voltage between FT-P and FT-N on INV Board has dropped to DC20V or less.

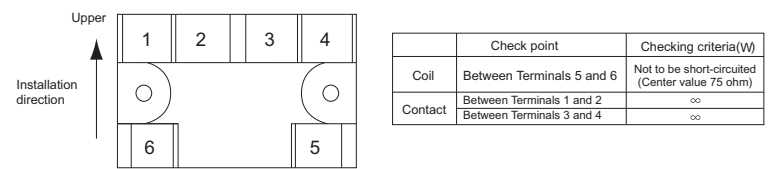
Part name	Judgment method											
IGBT module	See "Troubleshooting for IGBT Module ". (IX [4] - 6 - (6))											
Rush current protection resistor R1, R5	Measure the resistance between terminals R1 and R5: 22 ohm \pm 10%											
Electromagnetic relay 72C	<p>Note This electromagnetic relay is rated at DC12V and is driven by a coil. Check the resistance between terminals</p>  <p>The diagram shows a relay with terminals 1, 2, 3, 4 on the top row and 6, 5 on the bottom row. An arrow labeled 'Upper' points to the top row, and an arrow labeled 'Installation direction' points upwards. To the right is a table:</p> <table border="1"> <thead> <tr> <th></th> <th>Check point</th> <th>Checking criteria(W)</th> </tr> </thead> <tbody> <tr> <td>Coil</td> <td>Between Terminals 5 and 6</td> <td>Not to be short-circuited (Center value 75 ohm)</td> </tr> <tr> <td rowspan="2">Contact</td> <td>Between Terminals 1 and 2</td> <td>∞</td> </tr> <tr> <td>Between Terminals 3 and 4</td> <td>∞</td> </tr> </tbody> </table>		Check point	Checking criteria(W)	Coil	Between Terminals 5 and 6	Not to be short-circuited (Center value 75 ohm)	Contact	Between Terminals 1 and 2	∞	Between Terminals 3 and 4	∞
	Check point	Checking criteria(W)										
Coil	Between Terminals 5 and 6	Not to be short-circuited (Center value 75 ohm)										
Contact	Between Terminals 1 and 2	∞										
	Between Terminals 3 and 4	∞										
DC reactor DCL	Measure the resistance between terminals: 1ohm or lower (almost 0 ohm) Measure the resistance between terminals and the chassis: ∞											

(6) Troubleshooting for IGBT Module

Measure the resistances between each pair of terminals on the IGBT with a tester, and use the results for troubleshooting. The terminals on the INV board are used for the measurement.

1) Notes on measurement

- ♦Check the polarity before measuring. (On the tester, black normally indicates plus.)
- ♦Check that the resistance is not open (∞ ohm) or not shorted (to 0 ohm).
- ♦The values are for reference, and the margin of errors is allowed.
- ♦The result that is more than double or half of the result that is measured at the same measurement point is not allowed.
- ♦Disconnect all the wiring connected the INV board, and make the measurement.

2) Tester restriction

- ♦Use the tester whose internal electrical power source is 1.5V or greater
- ♦Use the dry-battery-powered tester.

Note

(The accurate diode-specific resistance cannot be measured with the button-battery-powered card tester, as the applied voltage is low.)

- ♦Use a low-range tester if possible. A more accurate resistance can be measured.

Judgment value (reference)

		Black				
		SC-P1	FT-N	SC-L1	SC-L2	SC-L3
Red	SC-P1	-	-	5 - 200 ohm	5 - 200 ohm	5 - 200 ohm
	FT-N	-	-	∞	∞	∞
	SC-L1	∞	5 - 200 ohm	-	-	-
	SC-L2	∞	5 - 200 ohm	-	-	-
	SC-L3	∞	5 - 200 ohm	-	-	-

		Black				
		SC-P2	FT-N	SC-U	SC-V	SC-W
Red	SC-P2	-	-	5 - 200 ohm	5 - 200 ohm	5 - 200 ohm
	FT-N	-	-	∞	∞	∞
	SC-U	∞	5 - 200 ohm	-	-	-
	SC-V	∞	5 - 200 ohm	-	-	-
	SC-W	∞	5 - 200 ohm	-	-	-

INV board external diagram

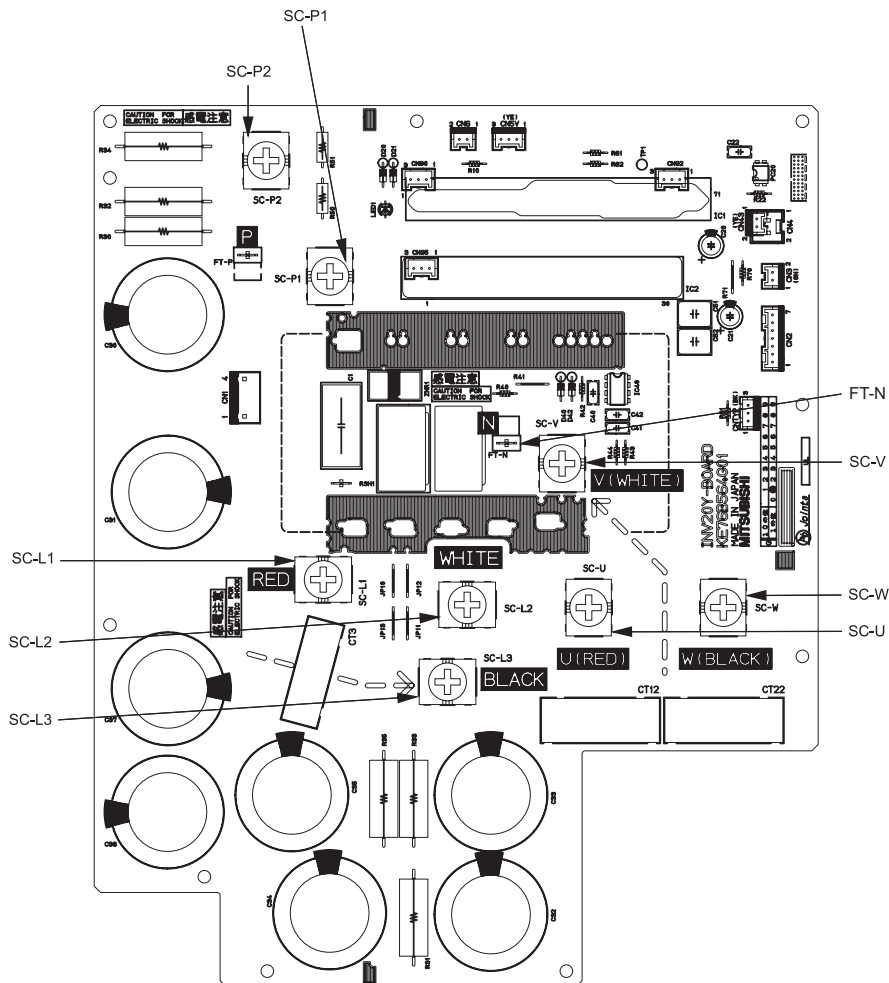

-7- Control Circuit (TLMU-A1)

(1) Control power source function block

1) PQHY-P72, P96, P120TLMU-A1, PQRY-P72, P96, P120TLMU-A1

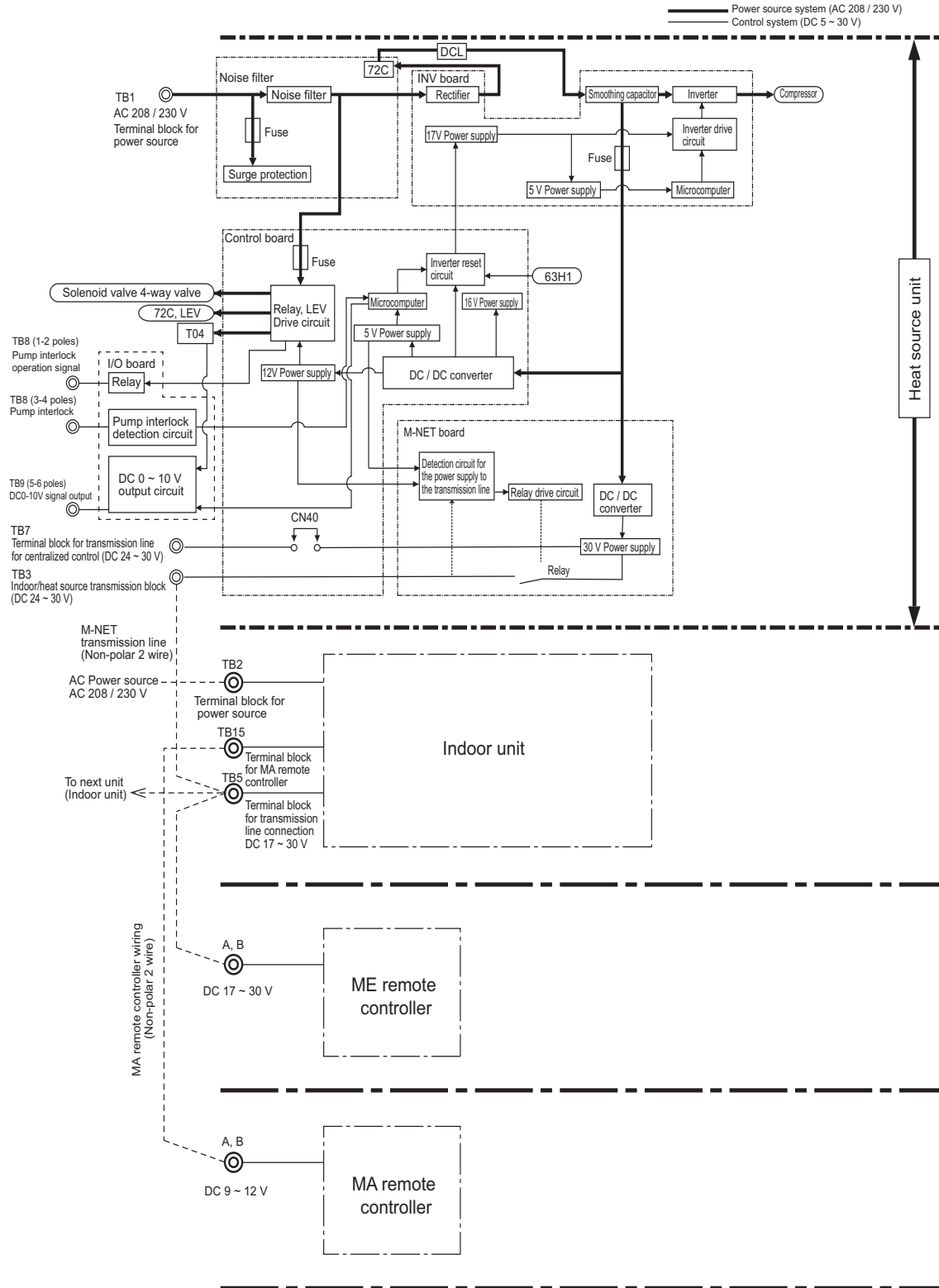

* MA remote controllers and ME remote controllers cannot be used together.
 (Both the ME and MA remote controller can be connected to a system with a system controller.)

2) PQHY-P144, P168, P192TLMU-A1, PQRV-P144, P168, P192TLMU-A1

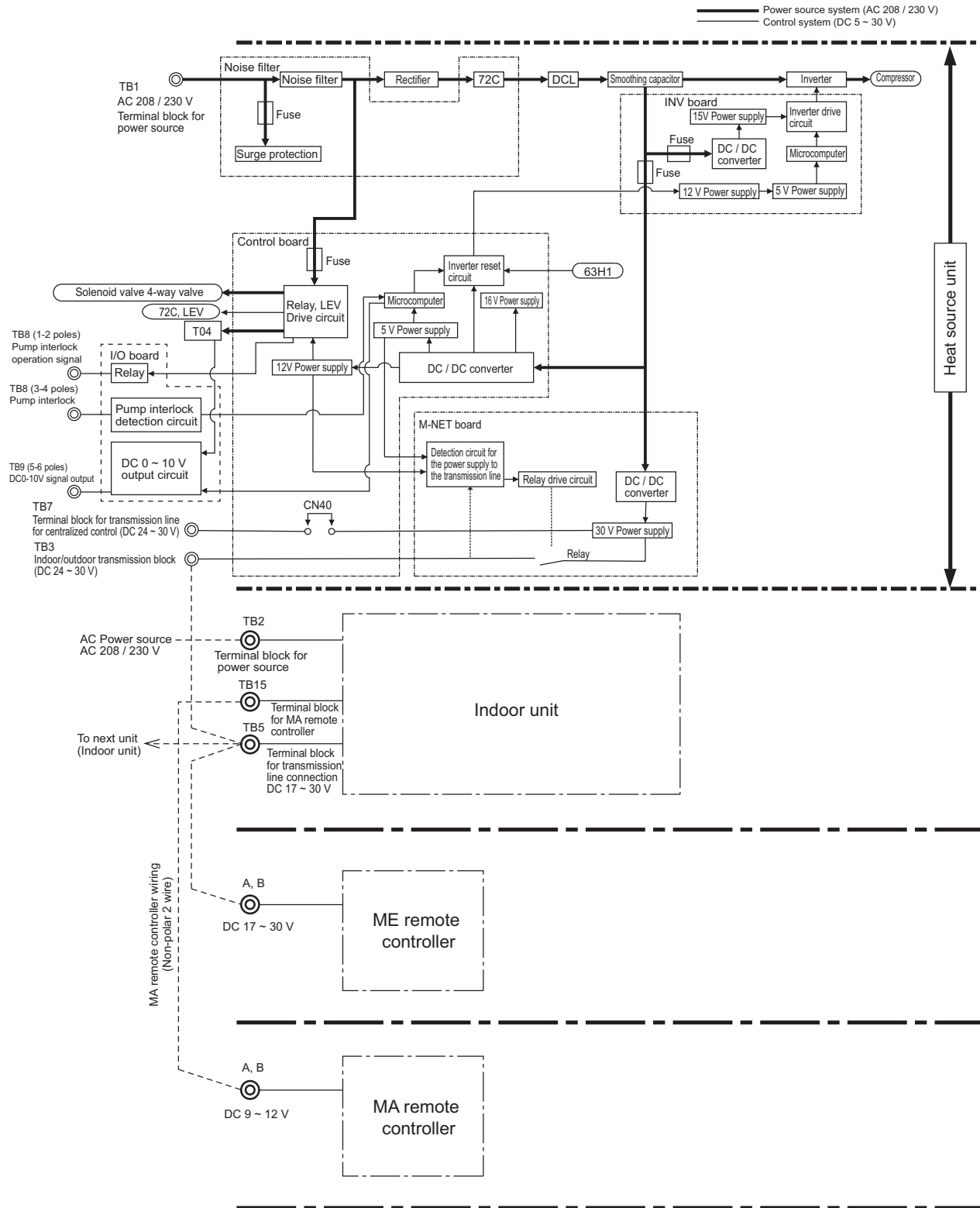

* MA remote controllers and ME remote controllers cannot be used together.
 (Both the ME and MA remote controller can be connected to a system with a system controller.)

3) PQHY-P216, P240TLMU-A1, PQRV-P216, P240TLMU-A1

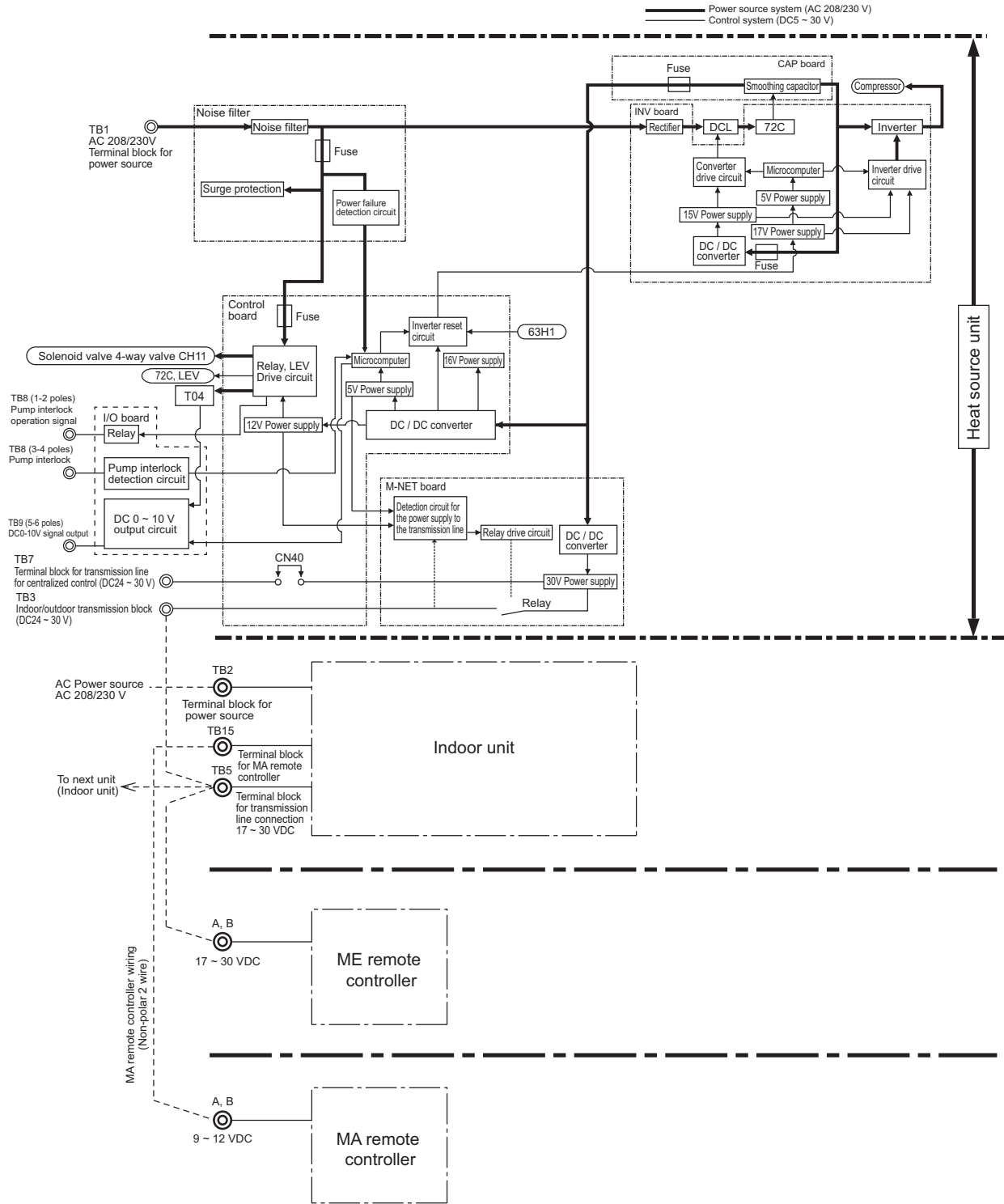

* MA remote controllers and ME remote controllers cannot be used together.
 (Both the ME and MA remote controller can be connected to a system with a system controller.)

(2) Troubleshooting transmission power circuit of heat source unit

1) PQHY-P72, P96, P120TLMU-A1, PQRV-P72, P96, P120TLMU-A1

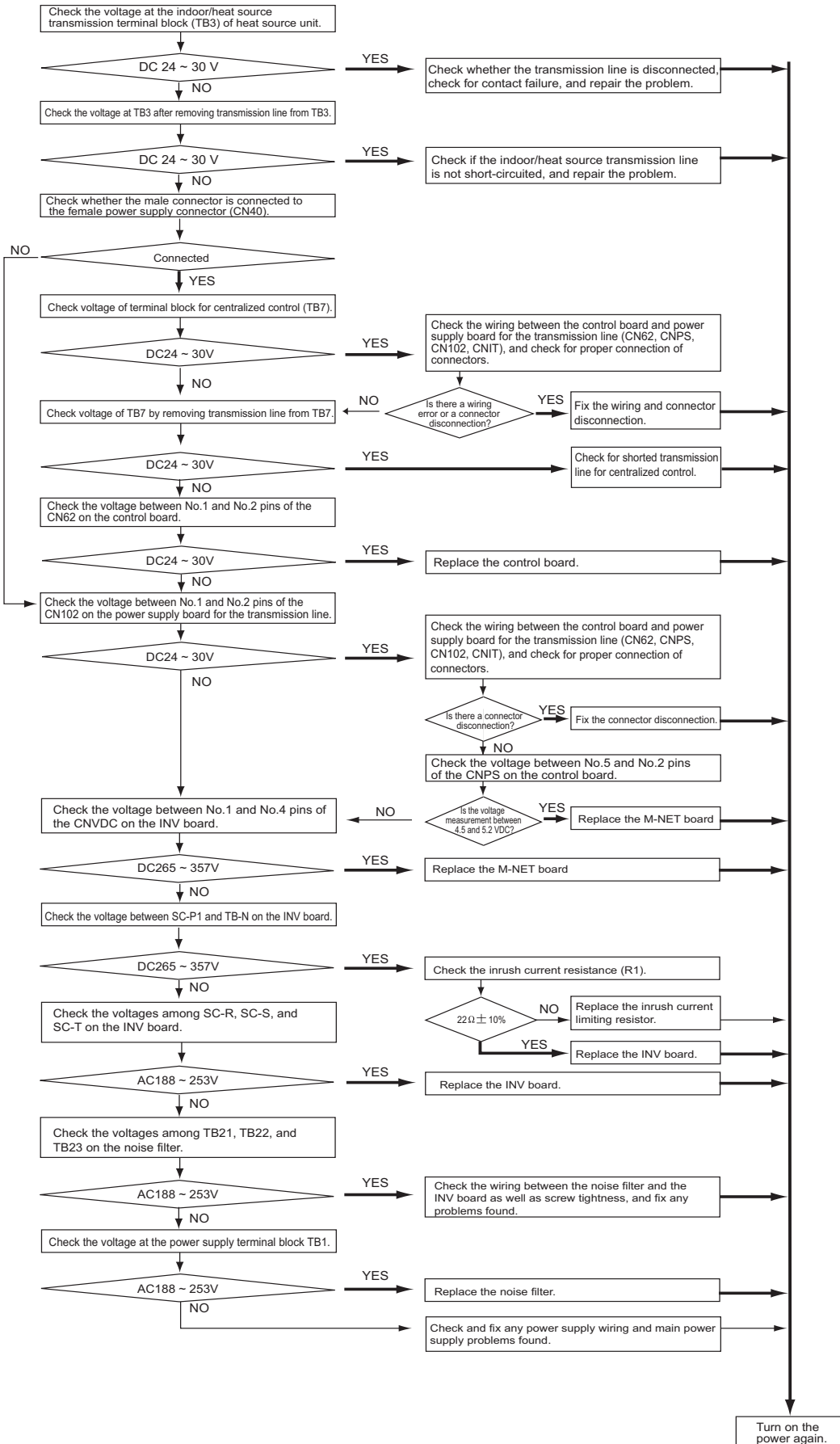

2) PQHY-P144, P168, P192TLMU-A1, PQRV-P144, P168, P192TLMU-A1

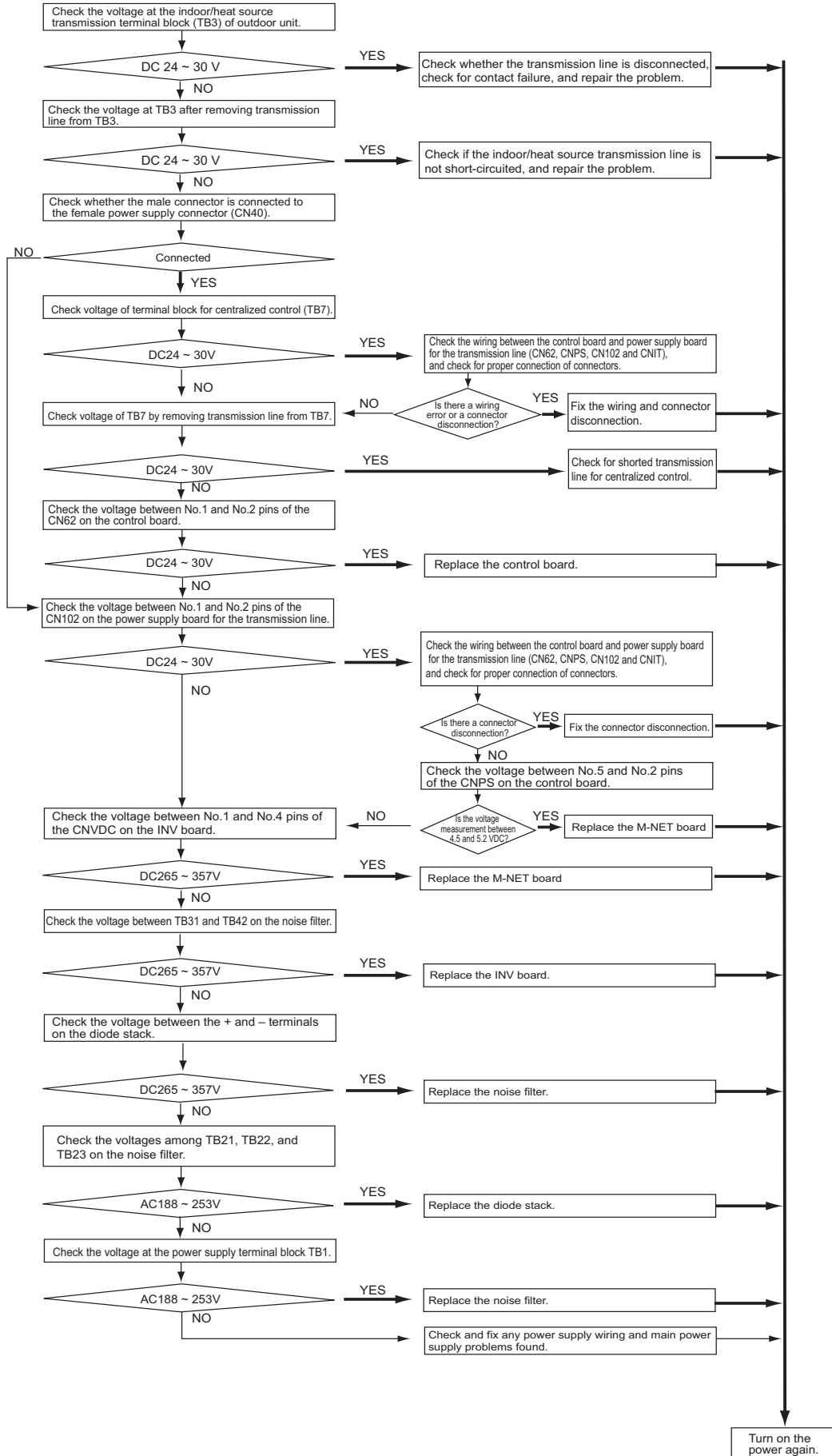

3) PQHY-P216, P240TLMU-A1, PQRV-P216, P240TLMU-A1

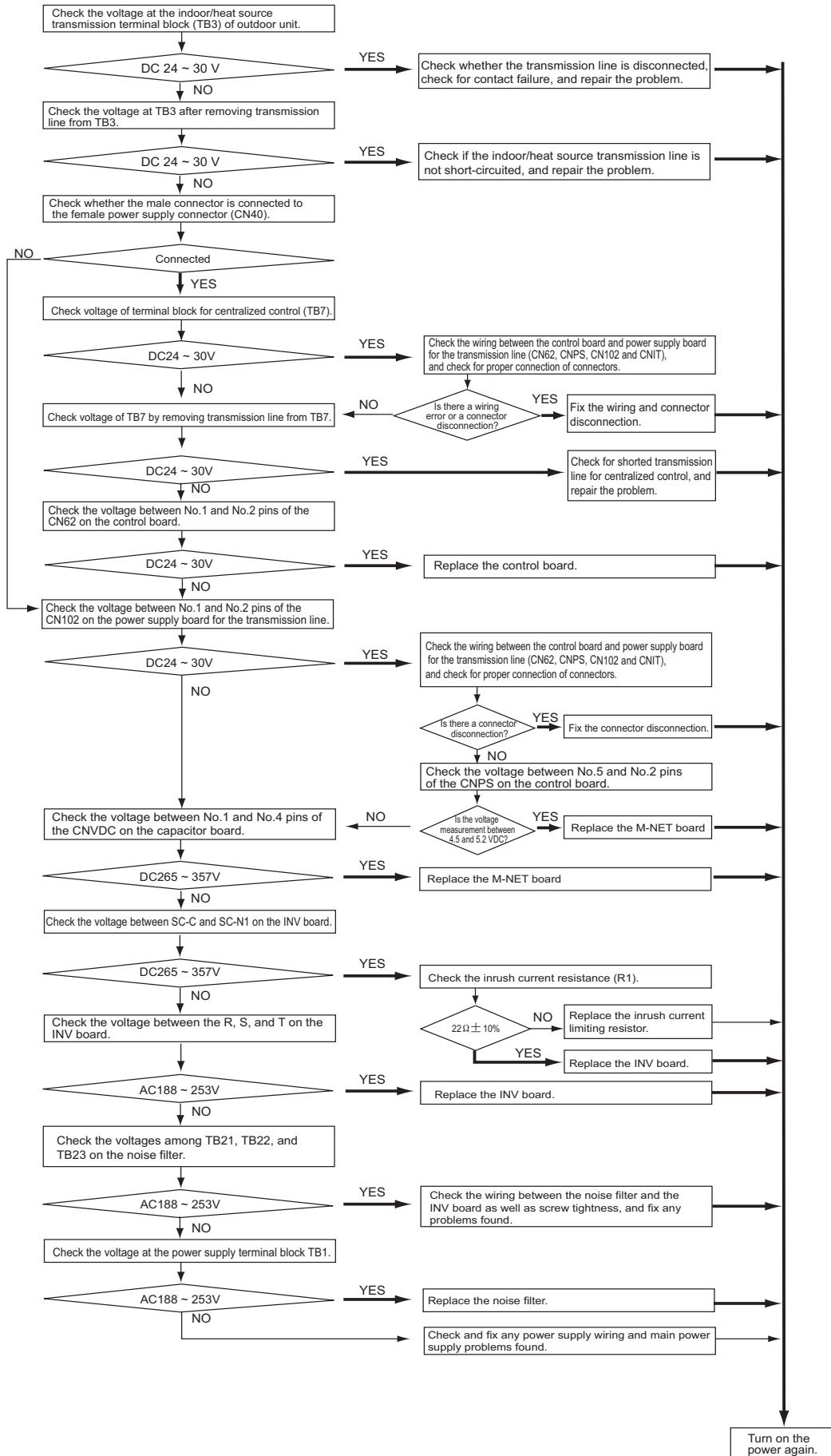

-7- Control Circuit (YLMU-A1)
(1) Control power source function block

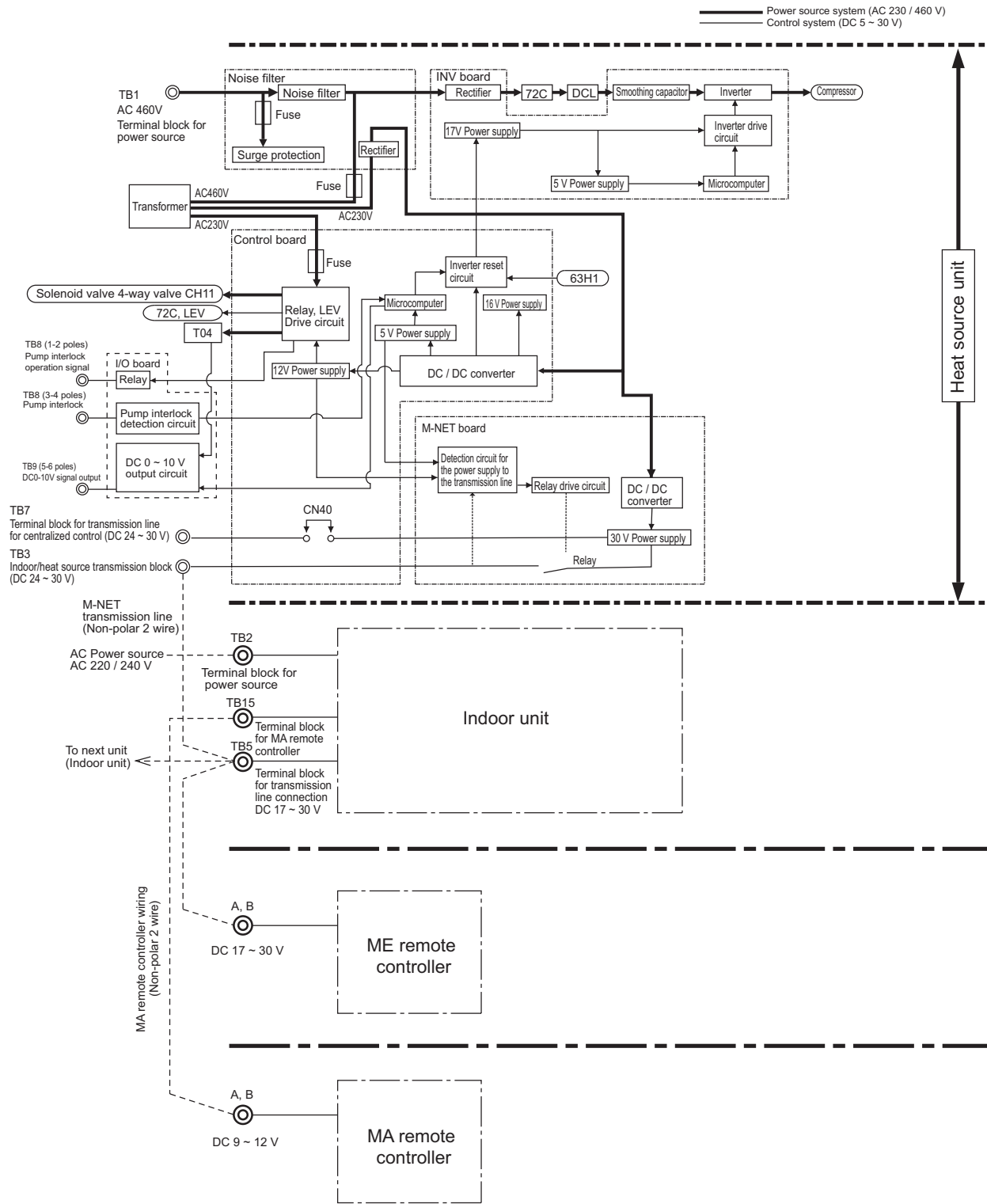

* MA remote controllers and ME remote controllers cannot be used together.
 (Both the ME and MA remote controller can be connected to a system with a system controller.)

(2) Troubleshooting transmission power circuit of heat source unit

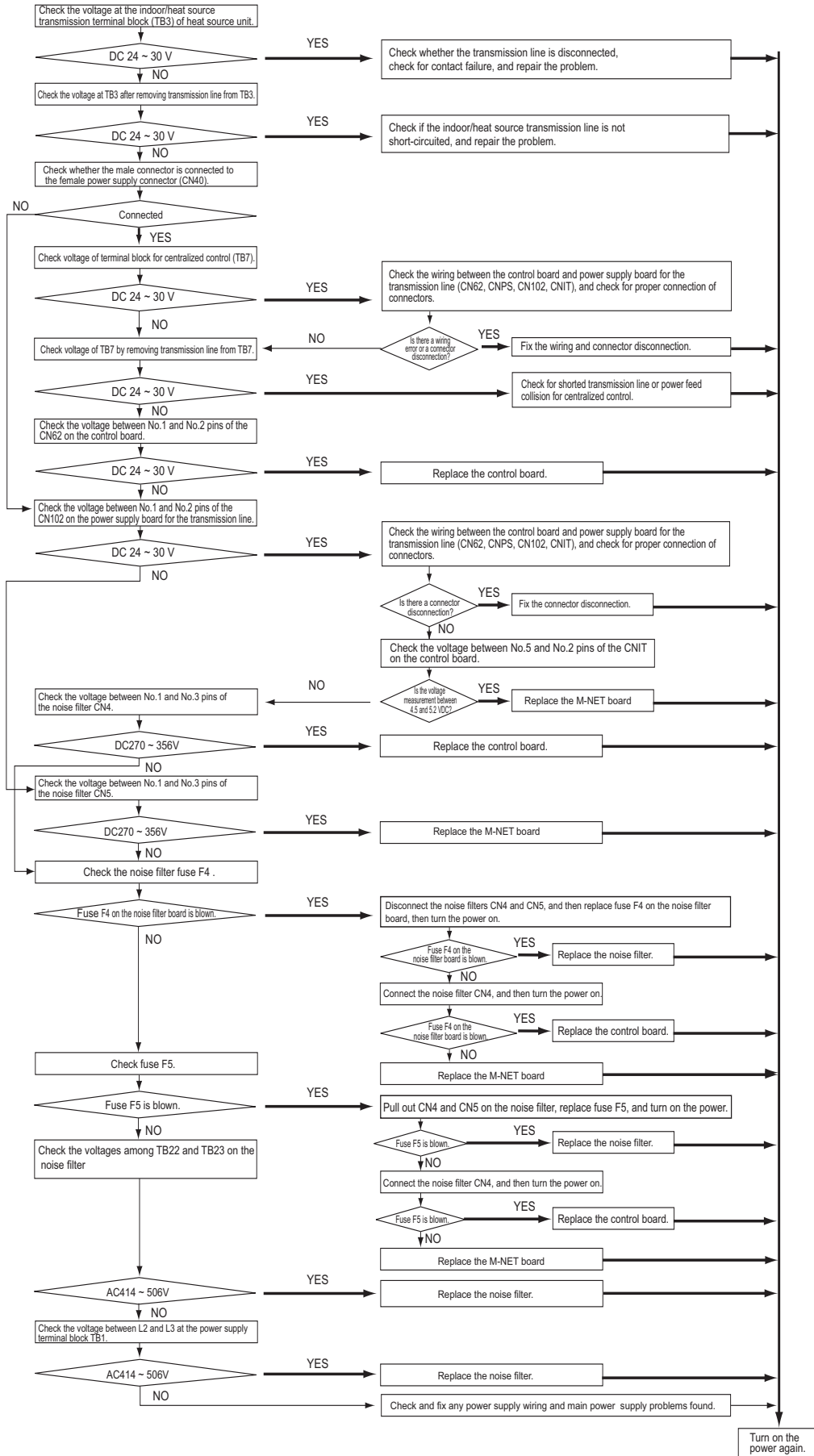

[5] Refrigerant Leak

Note

Refer to the relevant sections of the manual for how to set SW4 on the control board.

1. Leak spot: In the case of extension pipe for indoor unit (Cooling season)<PQHY>

- 1) Mount a pressure gauge on the service check joint (CJ2) on the low-pressure side.
- 2) Stop all the indoor units, and close the liquid service valve (BV2) inside the heat source unit while the compressor is being stopped.
- 3) Stop all the indoor units; turn on SW4 No.912 (SW6-10: ON) on the heat source unit control board while the compressor is being stopped.(Pump down mode will start, and all the indoor units will run in cooling test run mode.)
- 4) In the pump down mode SW4 No.912 (SW6-10: ON), all the indoor units will automatically stop when the low pressure (63LS) reaches 0.383MPa [55psi] or less or 15 minutes have passed after the pump mode started. Stop all the indoor units and compressors when the pressure indicated by the pressure gauge, which is on the check joint (CJ2) for low-pressure service, reaches 0.383MPa [55psi] or 20 minutes pass after the pump down operation is started.
- 5) Close the gas service valve (BV1) inside the heat source unit.
- 6) Collect the refrigerant that remains in the extended pipe for the indoor unit. Do not discharge refrigerant into the atmosphere when it is collected.
- 7) Repair the leak.
- 8) After repairing the leak, vacuum^{*1} the extension pipe and the indoor unit.
- 9) To adjust refrigerant amount, open the service valves (BV1 and BV2) inside the heat source unit and turn off SW4 No.912 (SW6-10: ON).

2. Leak spot: In the case of heat source unit (Cooling season)<PQHY>

(1) Run all the indoor units in the cooling test run mode.

- 1) To run the indoor unit in test run mode, turn on SW4 No.769 (SW6-10: ON) on the heat source control board.
- 2) Change the setting of the remote controller for all the indoor units to the cooling mode.
- 3) Check that all the indoor units are performing a cooling operation.

(2) Check the values of Tc and TH6.

(To display the values on the LED screen, use the self-diagnosis switch (SW4 (SW6-10: OFF)) on the heat source unit control board.)

- 1) When Tc-TH6 is 10°C [18°F] or more : See the next item (3).
- 2) When Tc-TH6 is less than 10°C [18°F] : After the compressor stops, collect the refrigerant inside the system, repair the leak, perform evacuation, and recharge new refrigerant. (Leak spot: 4. In the case of heat source unit, handle in the same way as heating season.)

Tc self-diagnosis switch

TH6 self-diagnosis switch

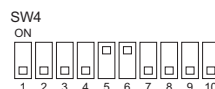

The figure at left shows that the switches 1 through 5 are set to ON and 6 through 10 are set to OFF.

(3) Stop all the indoor units, and stop the compressor.

- 1) To stop all the indoor units and the compressors, turn SW4 No.769 (SW6-10: ON) from ON to OFF on the heat source control board.
- 2) Check that all the indoor units are being stopped.

(4) Close the service valves (BV1 and BV2).

(5) To prevent the liquid seal, extract small amount of refrigerant from the check joint of the liquid service valve (BV2), as the liquid seal may cause a malfunction of the unit.

(6) Collect the refrigerant that remains inside the heat source unit. Do not discharge refrigerant into air into the atmosphere when it is collected.

(7) Repair the leak.

(8) After repairing the leak, replace the dryer with the new one, and perform evacuation inside the heat source unit.

(9) To adjust refrigerant amount, open the service valves (BV1 and BV2) inside the heat source unit.

Note

When the power to the heat source-indoor unit must be turned off to repair the leak after closing the service valves specified in the item 4, turn the power off in approximately one hour after the heat source-indoor units stop.

- 1) When 30 minutes have passed after the item 4 above, the indoor unit lev turns from fully closed to slightly open to prevent the refrigerant seal.
LEV2a and LEV2b open when the heat source unit remains stopped for 15 minutes to allow for the collection of refrigerant in the heat source unit heat exchanger and to enable the evacuation of the heat source unit heat exchanger.
If the power is turned off in less than 5 minutes, LEV2a and LEV2b may close, trapping high-pressure refrigerant in the heat source unit heat exchanger and creating a highly dangerous situation.
- 2) Therefore, if the power source is turned off within 30 minutes, the lev remains fully closed and the refrigerant remains sealed.
When only the power for the indoor unit is turned off, the indoor unit LEV turns from faintly open to fully closed.
- 3) In the cooling cycle, the section between "21S4b, c" and "LEV 2a, b" will form a closed circuit.
To recover the refrigerant or evacuate the system, "LEV1" and "SV5b, c" will be open by setting SW4 No.988 (SW6-10: ON) to ON in the stop mode.
Set SW4 No.988 (SW6-10: ON) to OFF upon completion of all work.

3. Leak spot: In the case of extension pipe for indoor unit (Heating season)<PQHY>

(1) Run all the indoor units in heating test run mode.

- 1) To run the indoor unit in test run mode, turn on SW4 No.769 (SW6-10: ON).
- 2) Change the setting of the remote controller for all the indoor units to the heating mode.
- 3) Check that all the indoor units are performing a heating operation.

(2) Stop all the indoor units, and stop the compressor.

- 1) To stop all the indoor units and the compressors, turn SW4 No.769 (SW6-10: ON) from ON to OFF.
- 2) Check that all the indoor units are stopped.

(3) Close the service valves (BV1 and BV2).

(4) Collect the refrigerant that remains inside the indoor unit. Do not discharge refrigerant into air into the atmosphere when it is collected.

(5) Repair the leak.

(6) After repairing the leak, perform evacuation*¹ of the extension pipe for the indoor unit, and open the service valves (BV1 and BV2) to adjust refrigerant.

4. Leak spot: In the case of heat source unit (Heating season)<PQHY>

- 1) Collect the refrigerant in the entire system (heat source unit, extended pipe and indoor unit). Do not discharge refrigerant into the atmosphere when it is collected.
- 2) Repair the leak.
- 3) After repairing the leak, replace the dryer with the new one, and perform evacuation of the entire system, and calculate the standard amount of refrigerant to be added (for heat source unit, extended pipe and indoor unit), and charge the refrigerant. Refer to "VIII [4] 3. "

Note

If the indoor or heat source units need to be turned off for repairing leaks during Step 1) above, turn off the power approximately 1 hour after the units came to a stop.

If the power is turned off in less than 15 minutes, LEV2a and LEV2b may close, trapping high-pressure refrigerant in the heat source unit heat exchanger and creating a highly dangerous situation.

In the cooling cycle, the section between "21S4b, c" and "LEV 2a, b" will form a closed circuit.

To recover the refrigerant or evacuate the system, "LEV1" and "SV5b, c" will be open by setting SW4 No.988 (SW6-10: ON) to ON in the stop mode.

Set SW4 No.988 (SW6-10: ON) to OFF upon completion of all work.

*1. Refer to Chapter I [8] Vacuum Drying (Evacuation) for detailed procedure.

5. Leak spot: In the case of extension pipe for indoor unit (Cooling season)<PQRY>

- 1) Mount a pressure gauge on the service check joint (CJ2) on the low-pressure side.
- 2) Stop all the indoor units, and close the high-pressure side refrigerant service valve (BV2) on the heat source unit while the compressor is being stopped.
- 3) Stop all the indoor units; turn on SW4 No.912 (SW6-10: ON) on the heat source unit control board while the compressor is being stopped.(Pump down mode will start, and all the indoor units will run in cooling test run mode.)
- 4) In the pump down mode (SW4 No.912 (SW6-10: ON) is ON), all the indoor units will automatically stop when the low pressure (63LS) reaches 0.383MPa [55psi] or less or 15 minutes have passed after the pump mode started. Stop all the indoor units and compressors when the pressure indicated by the pressure gauge, which is on the check joint (CJ2) for low-pressure service, reaches 0.383MPa [55psi] or 20 minutes pass after the pump down operation is started.
- 5) Close the service ball valve (BV1) on the low-pressure pipe on the heat source unit.
- 6) Collect the refrigerant that remains in the extended pipe for the indoor unit. Do not discharge refrigerant into the atmosphere when it is collected.
- 7) Repair the leak.
- 8) After repairing the leak, vacuum*1 the extension pipe and the indoor unit.
- 9) To adjust refrigerant amount, open the ball valves (BV1 and BV2) inside the heat source unit and turn off SW4 No.912 (SW6-10: ON).

6. Leak spot: In the case of heat source unit (Cooling season)<PQRY>

(1) Run all the indoor units in the cooling test run mode.

- 1) To run the indoor unit in test run mode, turn on SW4 No.769 (SW6-10: ON) on the heat source control board.
- 2) Change the setting of the remote controller for all the indoor units to the cooling mode.
- 3) Check that all the indoor units are performing a cooling operation.

(2) Check the SC16 value.

(This valve can be displayed on the LED by setting the self-diagnosis switch (SW4(SW6-10: OFF)) on the heat source unit control board.)

- 1) When SC16 is 10°C [18°F] or above: Go to the next item (3).
- 2) When the SC16 value is below 10°C [18°F]: After the compressor has stopped, extract the refrigerant in the system, repair the leak, evacuate the air from the system*1, and charge the system with refrigerant. (If the leak is in the heat source unit, follow the same procedure as listed under "heating season.")

SC16 self-diagnosis switch



The figure at left shows that the switches 1 through 5 are set to ON and 6 through 10 are set to OFF.

(3) Stop all the indoor units, and stop the compressor.

- 1) To stop all the indoor units and the compressors, turn SW4 No.769 (SW6-10: ON) from ON to OFF on the heat source control board.
- 2) Check that all the indoor units are being stopped.

(4) Close the ball valves (BV1 and BV2).

(5) Collect the refrigerant that remains inside the heat source unit. Do not discharge refrigerant into air into the atmosphere when it is collected.

(6) Repair the leak.

(7) After repairing the leak, replace the dryer with the new one, and perform evacuation*1 inside the heat source unit.

(8) To adjust refrigerant amount, open the ball valves (BV1 and BV2) inside the heat source unit.

*1. Refer to Chapter I [8] Vacuum Drying (Evacuation) for detailed procedure.

7. Leak spot: In the case of extension pipe for indoor unit (Heating season) <PQRY>

(1) Run all the indoor units in heating test run mode.

- 1) To run the indoor unit in test run mode, turn on SW4 No.769 (SW6-10: ON) on the heat source control board is ON.
- 2) Change the setting of the remote controller for all the indoor units to the heating mode.
- 3) Check that all the indoor units are performing a heating operation.

(2) Stop all the indoor units, and stop the compressor.

- 1) To stop all the indoor units and the compressors, turn SW4 No.769 (SW6-10: ON) from ON to OFF on the heat source control board.
- 2) Check that all the indoor units are stopped.

(3) Close the ball valves (BV1 and BV2).

(4) Collect the refrigerant that remains inside the indoor unit. Do not discharge refrigerant into air into the atmosphere when it is collected.

(5) Repair the leak.

(6) After repairing the leak, perform evacuation of the extension pipe^{*1} for the indoor unit, and open the ball valves (BV1 and BV2) to adjust refrigerant.

8. Leak spot: In the case of heat source unit (Heating season) <PQRY>

- 1) Collect the refrigerant in the entire system (heat source unit, extended pipe and indoor unit). Do not discharge refrigerant into the atmosphere when it is collected.
- 2) Repair the leak.
- 3) Repair the leak, and evacuate the air from the entire system^{*1}. Then, calculate the proper amount of refrigerant to be added (heat source unit + extension pipe + indoor unit), and charge the system with that amount. Refer to Chapter VIII [4] 4. for the proper amount of refrigerant charge.

*1. Refer to Chapter I [8] Vacuum Drying (Evacuation) for detailed procedure.

[6] Compressor Replacement Instructions

1. Compressor Replacement Instructions

Follow the procedures below (Steps 1 through 5) to remove the compressor components and replace the compressor. Reassemble them in the reverse order after replacing the compressor.

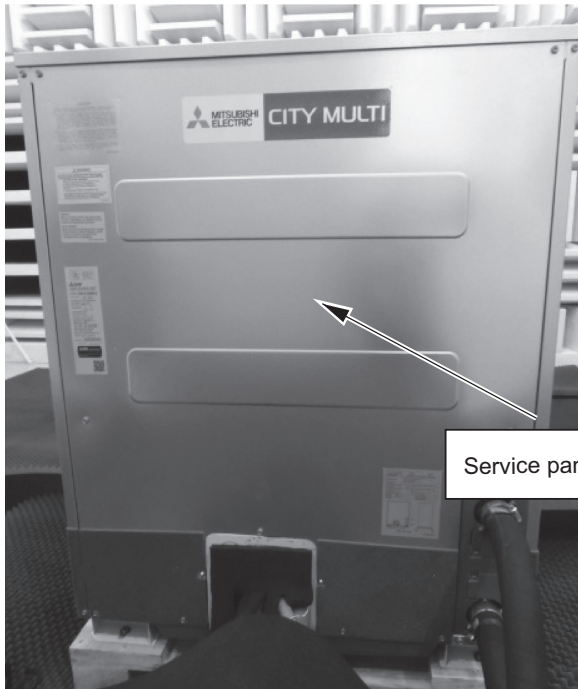

1. Remove the service panel (front panels).

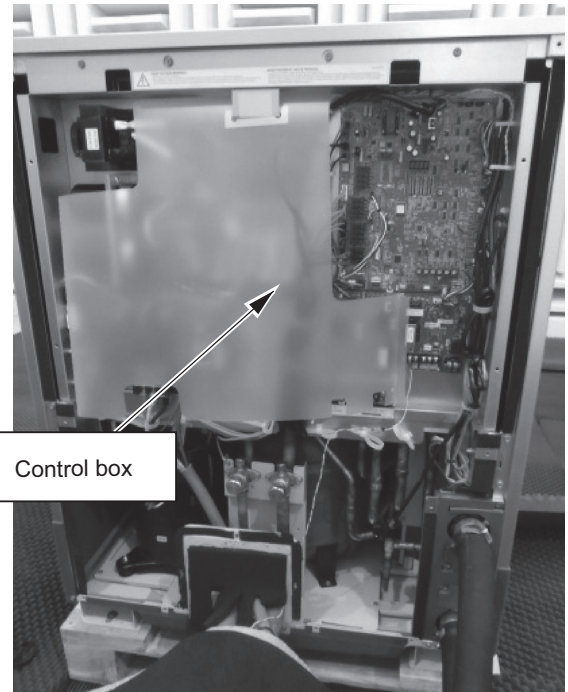

2. Remove the control box.

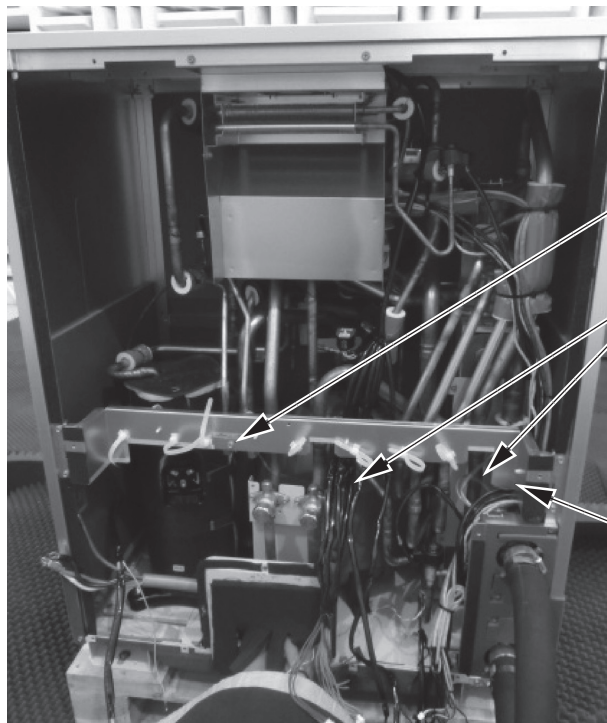

3. Remove the electrical wiring from the frame, unscrew the screws holding the check joint fixing plate, and remove the frame.

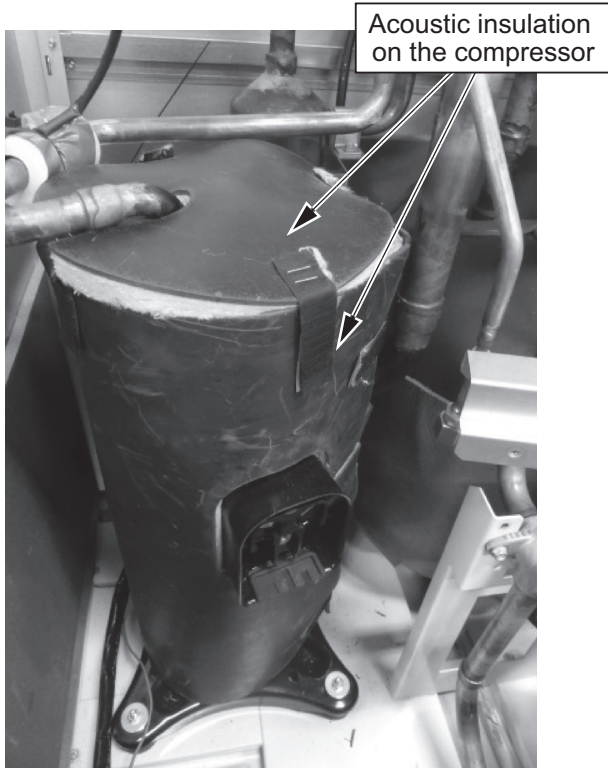

4. Remove the acoustic insulation from the compressor.

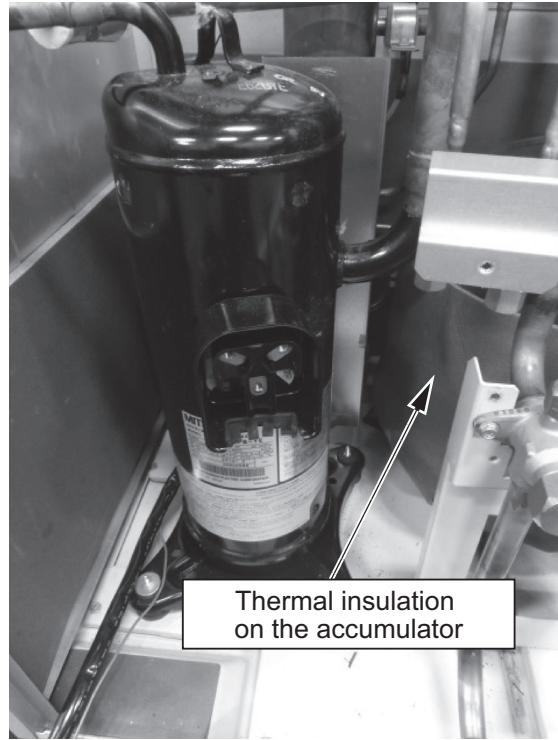

5. Remove or protect the wiring around the compressor and the thermal insulation on the accumulator, unbrazed the pipe from the compressor, and replace the compressor.

Follow the procedures below (Steps 1 through 4) to remove the compressor components and replace the compressor. Reassemble them in the reverse order after replacing the compressor.

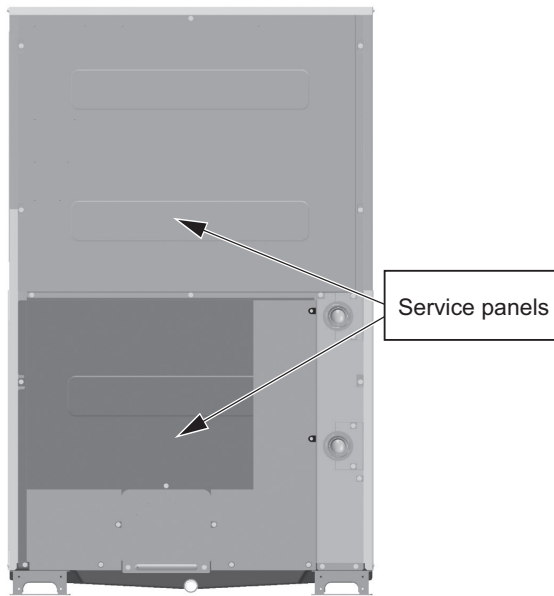

1. Remove the front service panels (top and bottom).

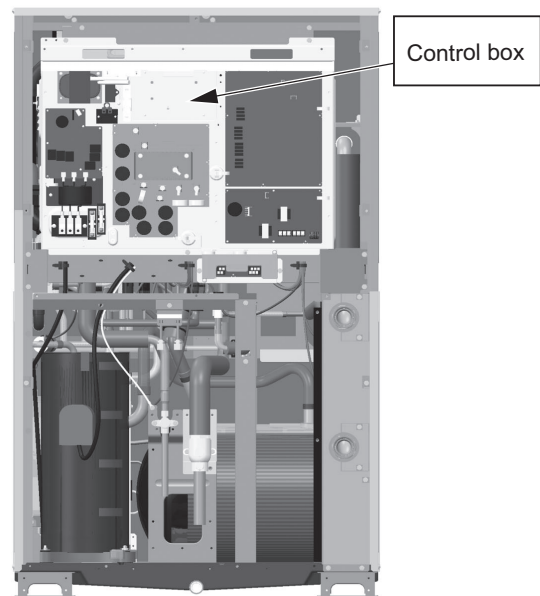

2. Remove the control box.

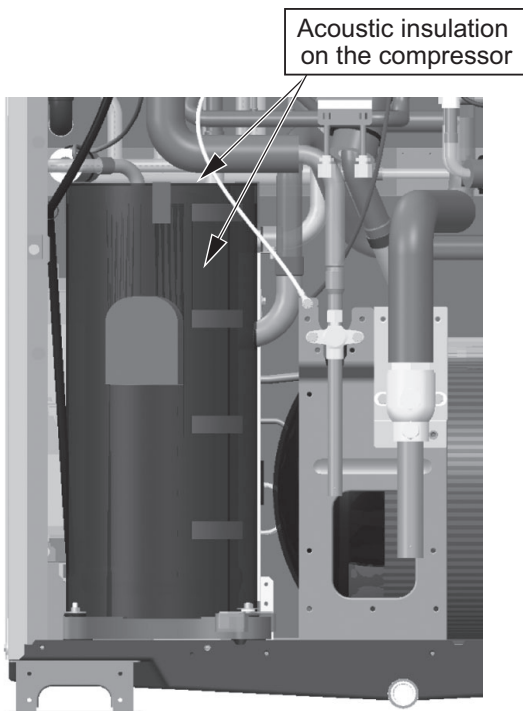

3. Remove the acoustic insulation material from the compressor.

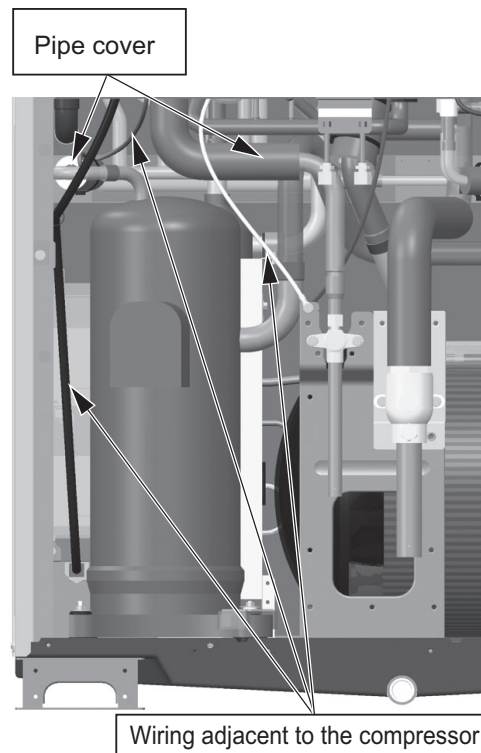

4. First, move the nearby wiring and the pipe covers out of the way or protect them from the brazing flame; then debraze the pipe, and replace the compressor.

[7] Water-cooled heat exchanger Replacement Instructions

1. Explained below are procedures for replacing water-cooled heat exchanger assembly parts.

2. Applicable models

- PQHY-P72, P96, P120TLMU-A1, PQHY-P72, P96, P120YLMU-A1
- PQRY-P72, P96, P120TLMU-A1, PQRY-P72, P96, P120YLMU-A1

3. Parts to be serviced

The procedures apply to the service parts listed in the table below.

No.	Parts to be replaced	Required materials	Qty.
1	Water-cooled heat exchanger assembly	Water-cooled heat exchanger service parts kit	1

4. Procedures

*** Precautions for starting replacement**

- Check that the main power supply is OFF.
- Check that no refrigerant is in the heat source unit.

Remove each part according to the 1)-8) procedures on the next page before replacing service parts.
Mount the removed parts back in place in a reversed procedures of 1)-8) on the next page after replacing service parts.

(1) Water-cooled heat exchanger assembly replacement procedures

● Removal procedures

- ① After removing the right panel (R), hang the beam of the Component cooler heat exchanger from the four-way valve piping to keep the Component cooler heat exchanger from falling downward, using a wire (see the right figure below).
- ② Remove the duct and the solenoid valve block support, pipe support, pipe fixing plate.
- ③ Hang the solenoid valve block and pipe from the four-way valve to keep the solenoid valve block and pipe from falling downward, using a wire (see the right figure below).
- ④ Unbrazing the pipe, remove the pipe assembly (see the left figure below), and remove the water heat exchanger fixing screws.
- ⑤ Pull out the water heat exchanger.

● Installation procedures

- ⑥ Install the replacement water heat exchanger.
- ⑦ Reinstall the water heat exchanger fixing screws, solenoid valve block support, pipe support, pipe fixing plate and duct as they were.

*** Precautions for replacing water-cooled heat exchanger assembly**

- Be sure to perform no-oxidation brazing when brazing.
- After brazing, check the condition around the brazing. After confirming no leakage, evacuate the air inside. (*1)
- Perform brazing with care of the flame direction so that it does not burn cables and plates etc. in the unit.

*1: Refer to Chapter I [8] Vacuum Drying (Evacuation) for detailed procedure.

2) Remove all wiring from the unit to the control box, and remove the control box from the unit.

6) Remove the top panel.

4) Remove the rear panel.

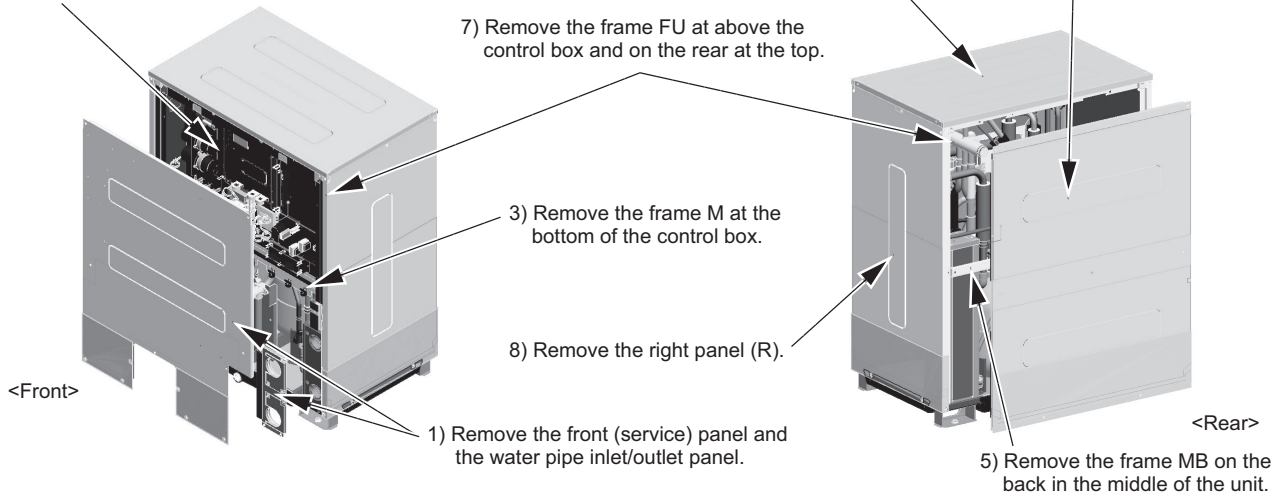

- ① After removing the right panel (R), hang the beam of the Component cooler heat exchanger from the four-way valve piping to keep the Component cooler heat exchanger from falling downward, using a wire (see the right figure below).
- ② Remove the duct and the solenoid valve block support, pipe support, pipe fixing plate.
- ③ Hang the solenoid valve block and pipe from the four-way valve to keep the solenoid valve block and pipe from falling downward, using a wire (see the right figure below).

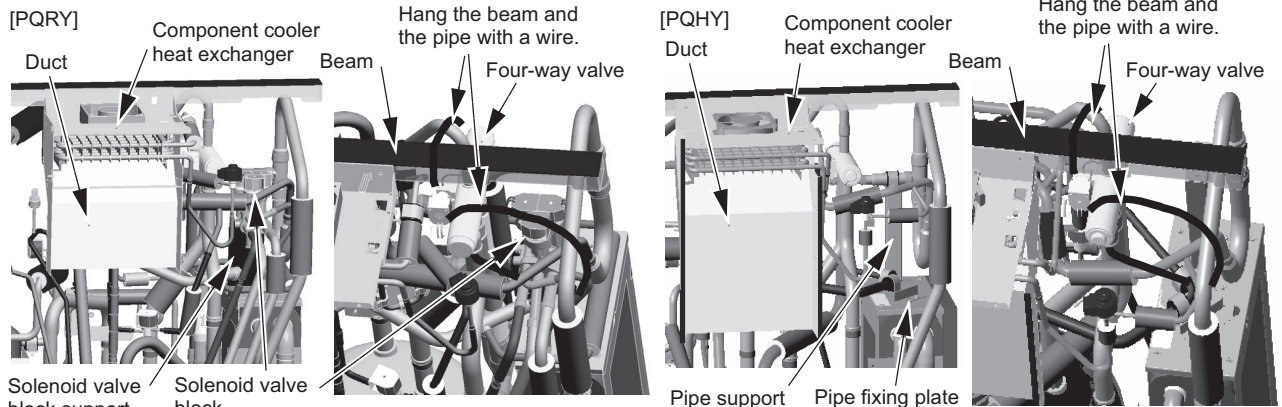

④ Unbraid the pipe, remove the pipe assembly (see the left figure below), and remove the water heat exchanger fixing screws.

⑤ Pull out the water heat exchanger.

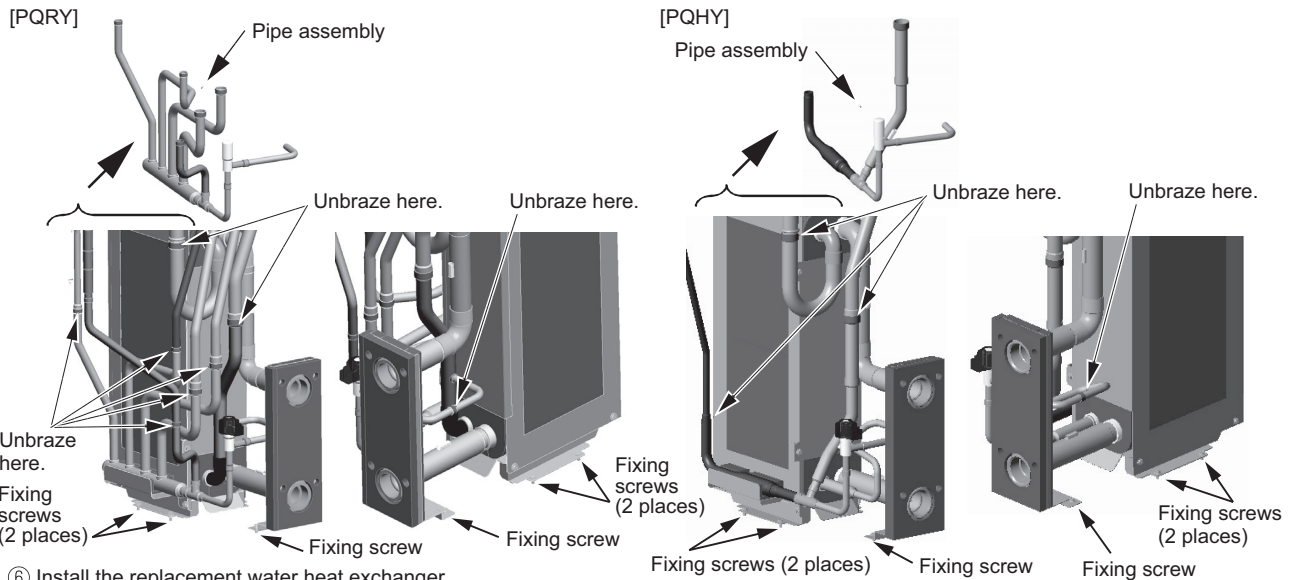

⑥ Install the replacement water heat exchanger.

⑦ Reinstall the water heat exchanger fixing screws, solenoid valve block support, pipe support, pipe fixing plate and duct as they were.

1. Explained below are procedures for replacing water-cooled heat exchanger assembly parts.

2. Applicable models

- PQHY-P144, P168, P192TLMU-A1, PQHY-P144, P168, P192YLMU-A1
- For the units manufactured in Mar. 2015.

3. Service parts list

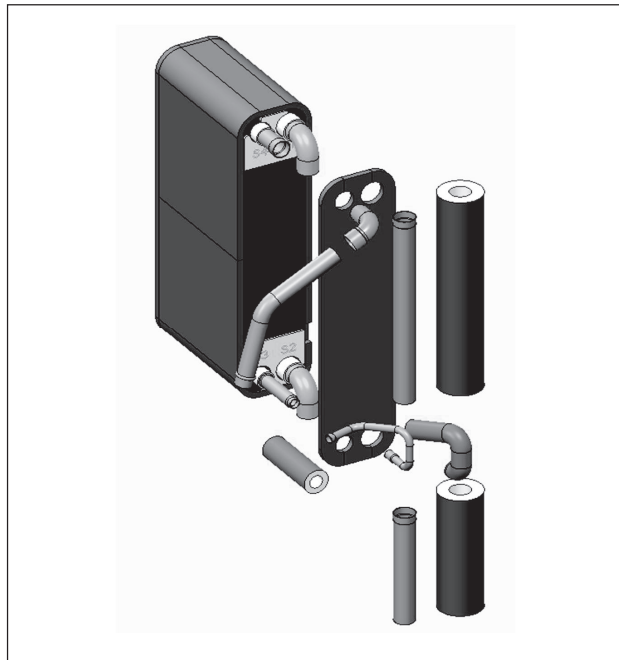

4. Procedures

***Precautions for starting replacement**

- Check that the main power supply is OFF.
- Check that no refrigerant is in the heat source unit.

Remove each part according to the 1)-6) procedures before replacing service parts.
Mount the removed parts back in place in a reversed procedures of 1)-6) after replacing service parts.

1) To remove the Duct

Remove the screw (total 4 places).

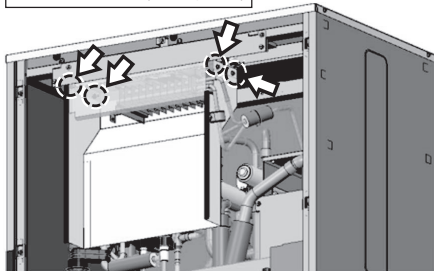

After removing Duct.

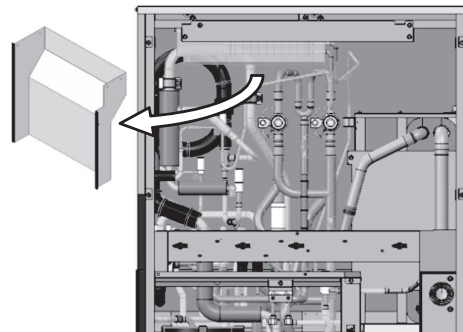

2) To remove the 4-Way Valve Assy

Debraze the pipe. (total 6 places)

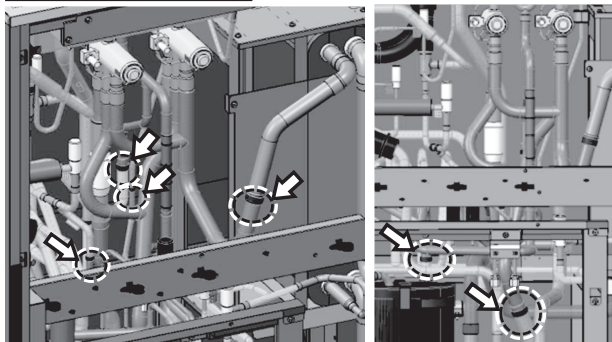

After removing 4-Way Valve Assy.

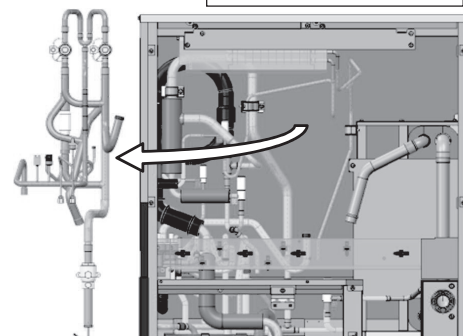

3) To remove the Header Assy

Debraz the pipe. (total 2 places)

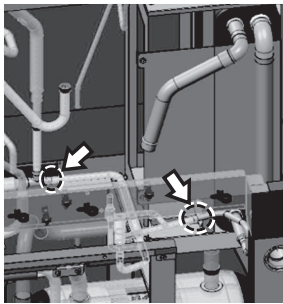

After removing Header Assy.

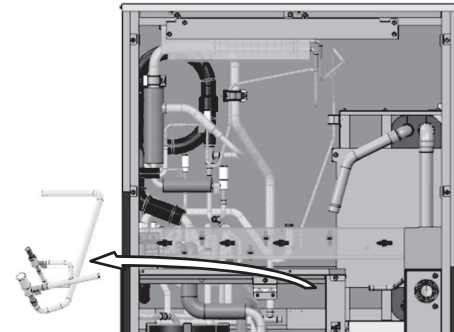

4) To remove the front panel of the Water Heat Exchanger and the side plate

①Remove the screw (total 6 places).

②Debraz the pipe.(total 1 place)

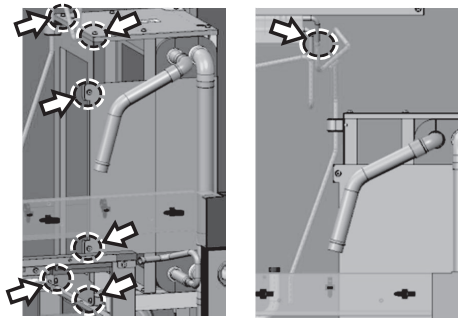

After removing the plate.

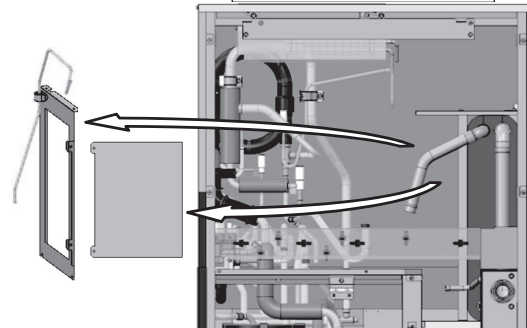

5) To remove the water pipe (2 pipes)

①Cut the pipe as shown in the figure (total 2 places), and debraz the pipe.

②Remove the screw that is fixed to the Partition Plate (total 4 places), and remove the Partition Plate.

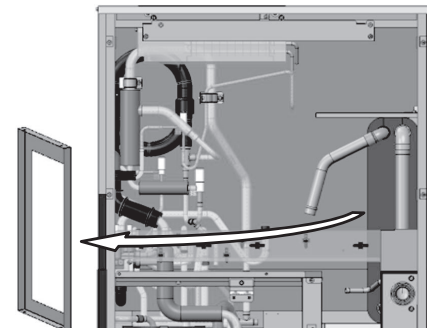
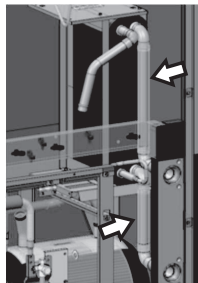

6) To move the Water Heat Exchanger

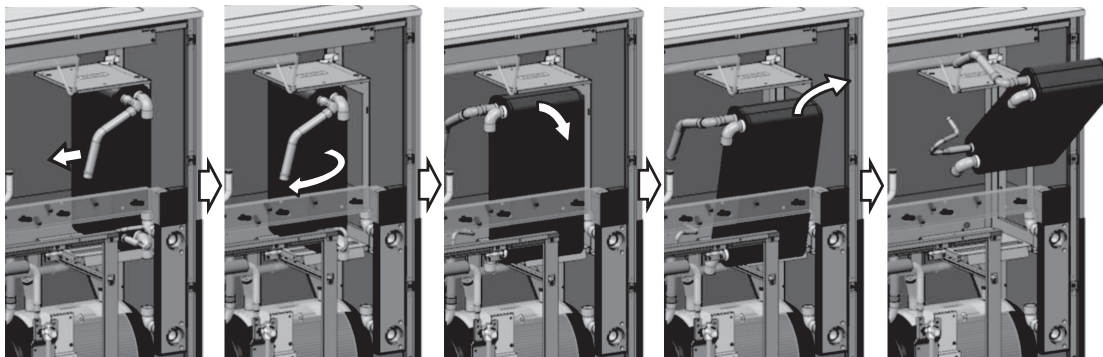

*** Precautions for brazing**

- Be sure to perform no-oxidation brazing when brazing.
- After brazing, check the condition around the brazing. After confirming no leakage, evacuate the air inside.
- Perform brazing with care of the flame direction so that it does not burn cables and plates etc. in the unit.

1. Explained below are procedures for replacing water-cooled heat exchanger assembly parts.

2. Applicable models

- PQHY-P144, P168, P192TLMU-A1, PQHY-P144, P168, P192YLMU-A1
- For the units manufactured after Apr. 2015.

3. Service parts list

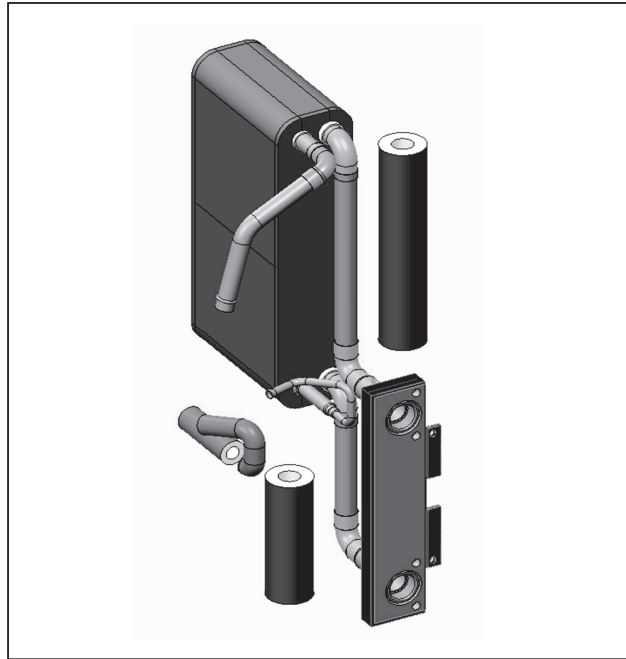

4. Procedures

- *Precautions for starting replacement**
- Check that the main power supply is OFF.
 - Check that no refrigerant is in the heat source unit.

Remove each part according to the 1)-5) procedures before replacing service parts.
Mount the removed parts back in place in a reversed procedures of 1)-5) after replacing service parts.

1) To remove the control box and the wire

① Remove the screw that is fixed to the Service Panel (total 17 places), and remove the service panel (front panel).

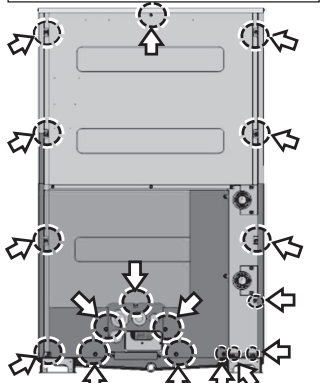

④ Remove the control box.

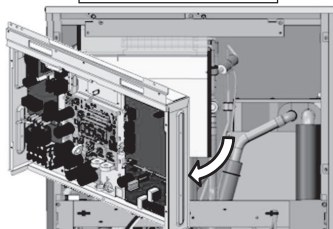

② Disconnect the wiring from the circuit board as shown in the figure.

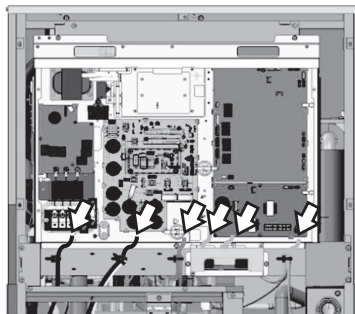

⑤ Remove the pipe cover and cable tie (total 3 places), and then disconnect the wire and sensor (TH7, TH8).

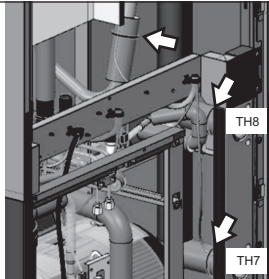

③ Remove the screw that is fixed to the I/O box (total 2 places), and remove the I/O box.

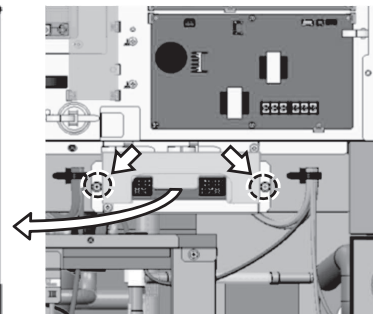

⑥ Remove the wire from cable strap on the Frame M.

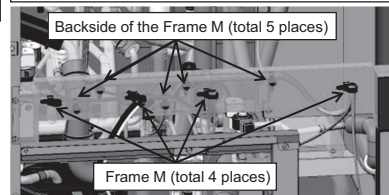

2) To remove the Frame M

① Remove the screw. (total 4 places)

② Turn FRAME M Right Side, Pull out.

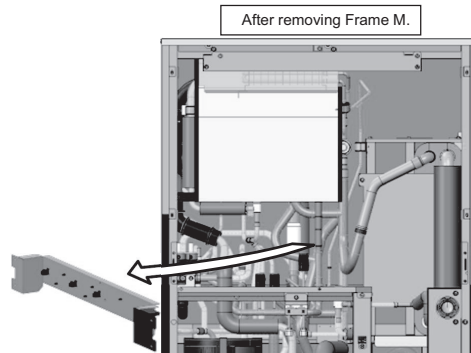
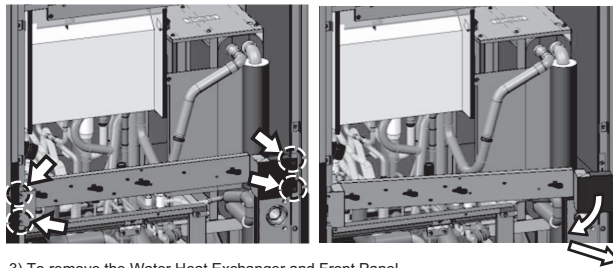

3) To remove the Water Heat Exchanger and Front Panel

① Remove the screw (total 2 places) and pipe cover, and then remove the Front Panel according to the 1-5 procedures on the figure below.

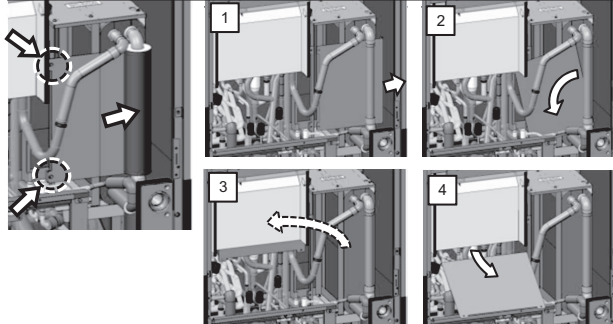

After removing Front Panel.

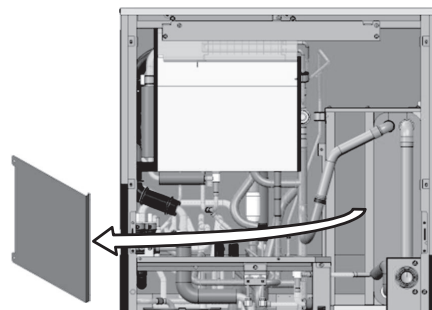

4) To move the Water Heat Exchanger and the Partition Plate

① Remove the Screw. (total 4 places)

② To move the Partition Plate to the left.

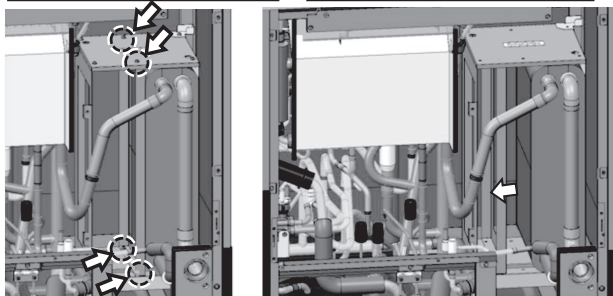

5) To remove the water heat exchanger

① Remove the screw (total 2 places). and debraze the pipe (total 2 places).

② To move the Water Heat Exchanger to the left.

③ Pull out in front Water Heat Exchanger.

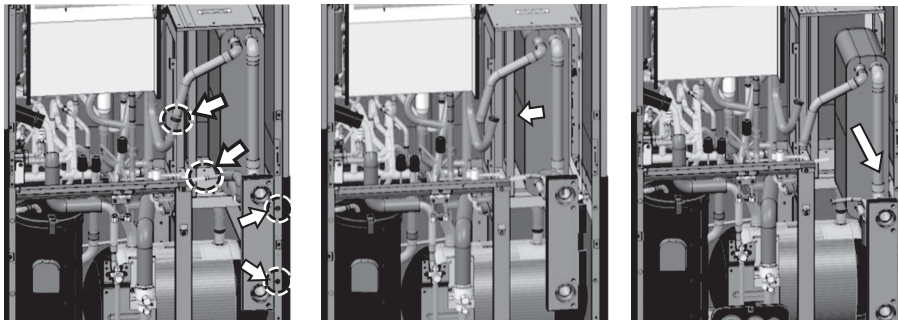

* Precautions for brazing

- Be sure to perform no-oxidation brazing when brazing.
- After brazing, check the condition around the brazing. After confirming no leakage, evacuate the air inside.
- Perform brazing with care of the flame direction so that it does not burn cables and plates etc. in the unit.

1. Explained below are procedures for replacing water-cooled heat exchanger assembly parts.

2. Applicable models

- PQHY-P216, P240TLMU-A1, PQHY-P216, P240YLMU-A1

3. Service parts list

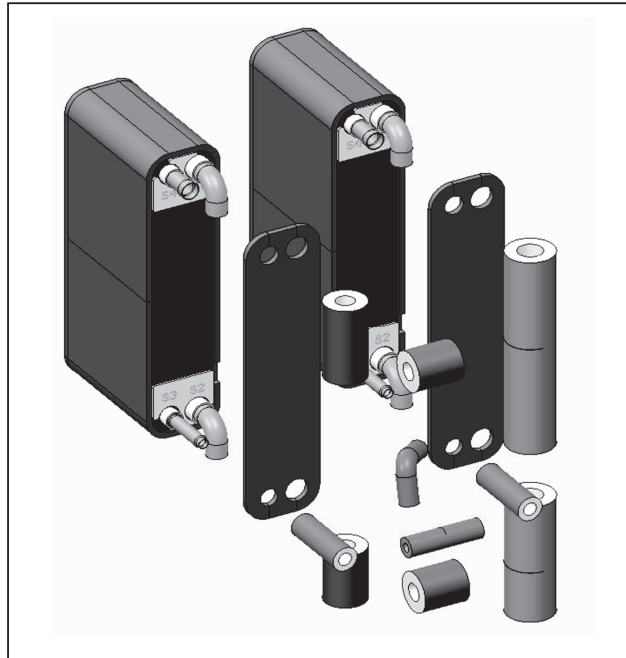

4. Procedures

***Precautions for starting replacement**

- Check that the main power supply is OFF.
- Check that no refrigerant is in the heat source unit.

Remove each part according to the 1)-4) procedures before replacing service parts.

Mount the removed parts back in place in a reversed procedures of 1)-4) after replacing service parts.

1) To remove the control box and the wire

① Remove the screw that is fixed to the Service Panel (total 17 places), and remove the Service Panel (Front Panel).

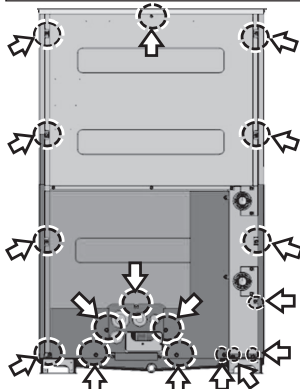

④ Remove the control box.

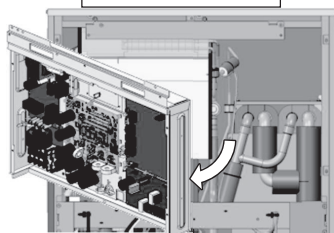

② Disconnect the wiring from the circuit board as shown in the figure.

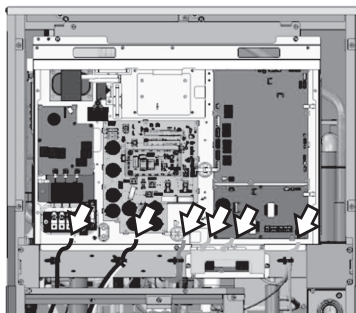

⑤ Remove the pipe cover and cable tie (total 3 places), and then disconnect the wire and sensor (TH7, TH8).

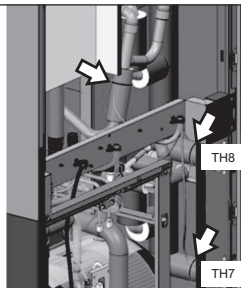

③ Remove the screw that is fixed to the I/O box (total 2 places), and remove the I/O box.

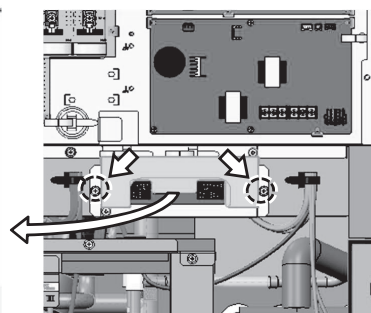

⑥ Remove the wire from cable strap on the Frame M.

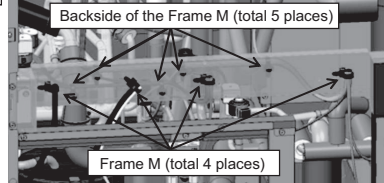

2) To remove the Frame M

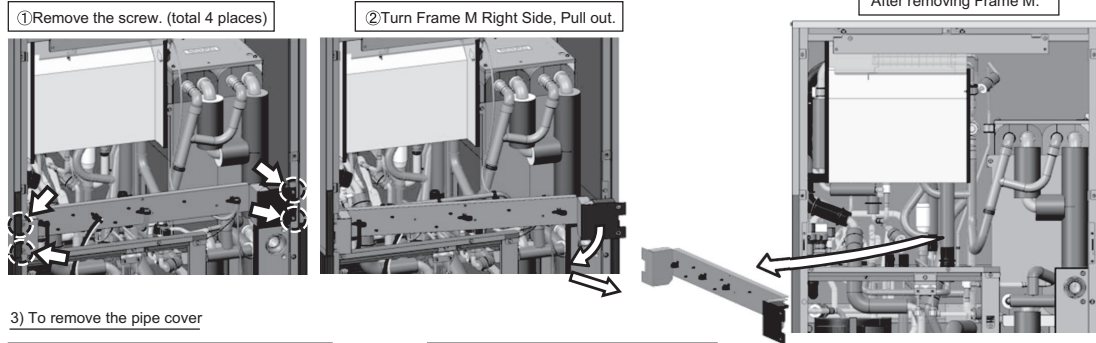

3) To remove the pipe cover

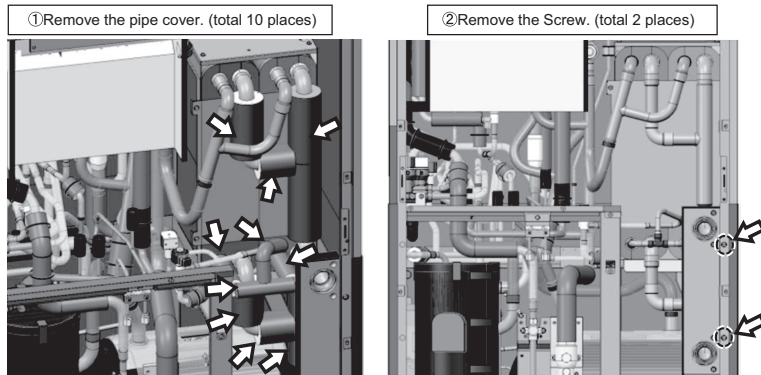

4) To remove the pipe from the Water Heat Exchanger

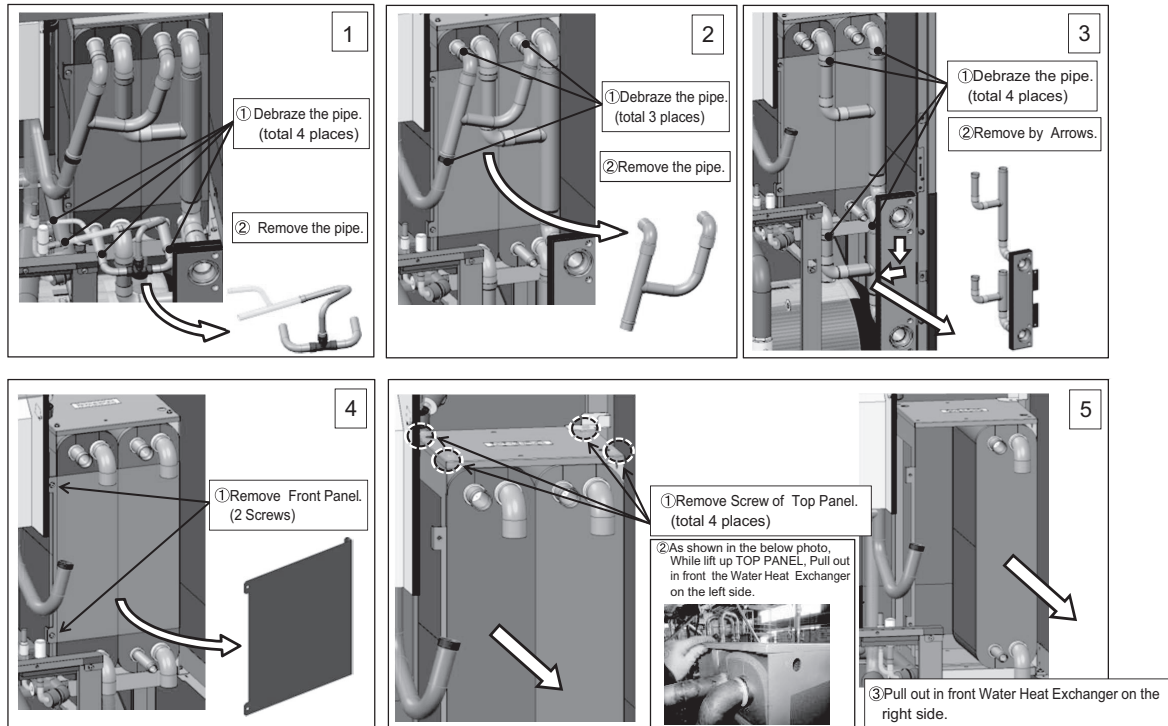

* Precautions for brazing

- Be sure to perform no-oxidation brazing when brazing.
- After brazing, check the condition around the brazing. After confirming no leakage, evacuate the air inside.
- Perform brazing with care of the flame direction so that it does not burn cables and plates etc. in the unit.

1. Explained below are procedures for replacing water-cooled heat exchanger assembly parts.

2. Applicable models

- PQRY-P144, P168, P192TLMU-A1, PQRY-P144, P168, P192YLMU-A1

3. Service parts list

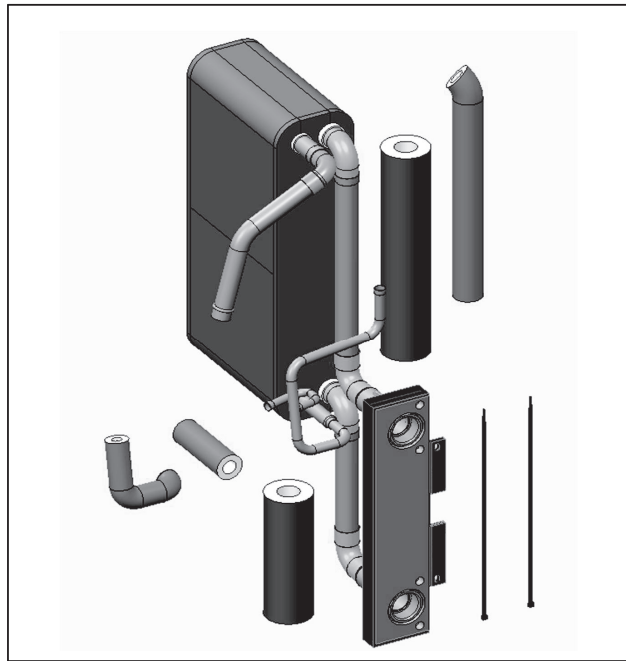

4. Procedures

***Precautions for starting replacement**

- Check that the main power supply is OFF.
- Check that no refrigerant is in the heat source unit.

Remove each part according to the 1)-5) procedures before replacing service parts.

Mount the removed parts back in place in a reversed procedures of 1)-5) after replacing service parts.

1) To remove the control box and the wire

① Remove the screw that is fixed to the Service Panel (total 17 places), and remove the service panel (front panel).

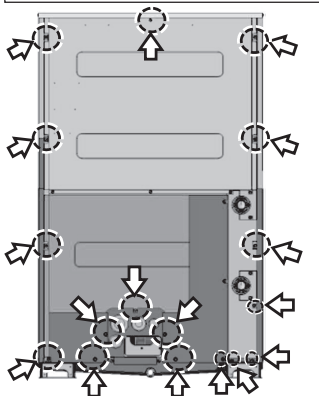

④ Remove the control box.

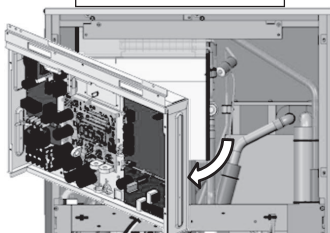

② Disconnect the wiring from the circuit board as shown in the figure.



⑤ Remove the pipe cover and cable tie (total 3 places), and then disconnect the wire and sensor (TH7, TH8).

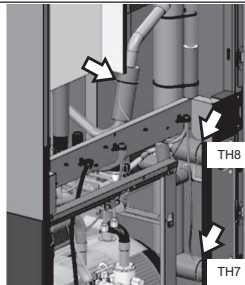

③ Remove the screw that is fixed to the I/O box (total 2 places), and remove the I/O box.

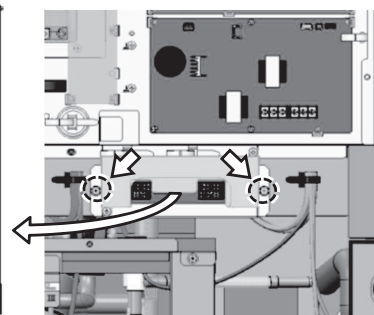

⑥ Remove the wire from cable strap on the Frame M.

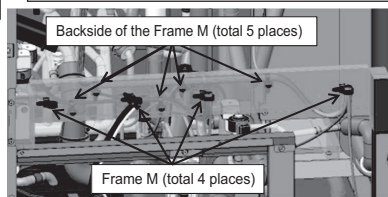

Backside of the Frame M (total 5 places)

Frame M (total 4 places)

2) To remove the Frame M

① Remove the screw. (total 4 places)

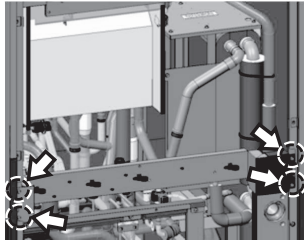

② Turn Frame M Right Side, Pull out.

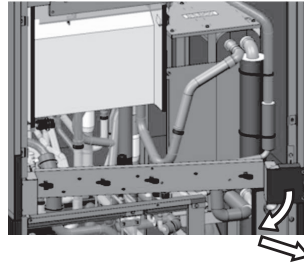

After removing Frame M.

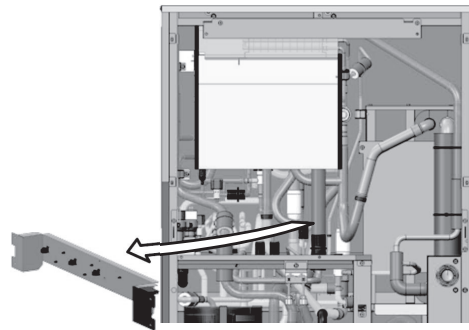

3) To remove the Water Heat Exchanger and Front Panel

① Remove the screw (total 2 places), pipe cover and cable tie (total 2 places), and then remove the Front Panel according to the 1-5 procedures on the figure below.

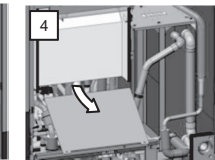
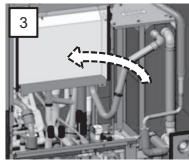
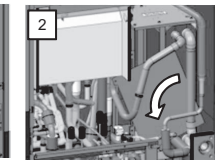
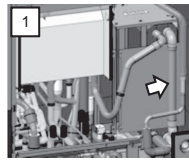
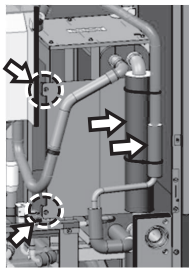

After removing Front Panel.

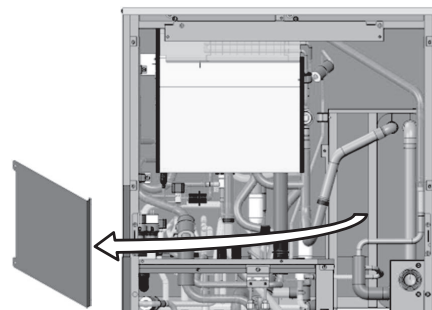

4) To move the Water Heat Exchanger and the Partition Plate

① Remove the Screw. (total 4 places)

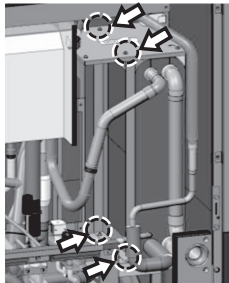

② To move the Partition Plate to the left.

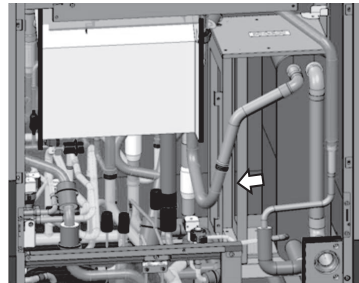

5) To remove the water heat exchanger

① Remove the screw (total 2 places), and debraise the pipe (total 3 places).

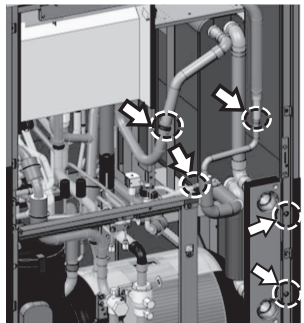

② To move the Water Heat Exchanger to the left.

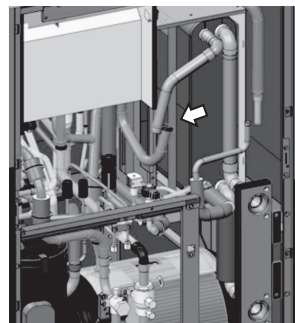

③ Pull out in front Water Heat Exchanger.

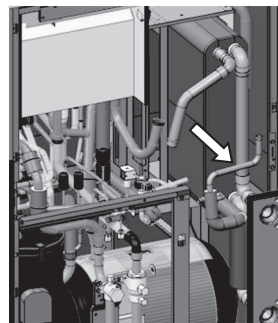

* Precautions for brazing

- Be sure to perform no-oxidation brazing when brazing.
- After brazing, check the condition around the brazing. After confirming no leakage, evacuate the air inside.
- Perform brazing with care of the flame direction so that it does not burn cables and plates etc. in the unit.

1. Explained below are procedures for replacing water-cooled heat exchanger assembly parts.

2. Applicable models

- PQRV-P216, P240TLMU-A1, PQRV-P216, P240YLMU-A1

3. Service parts list

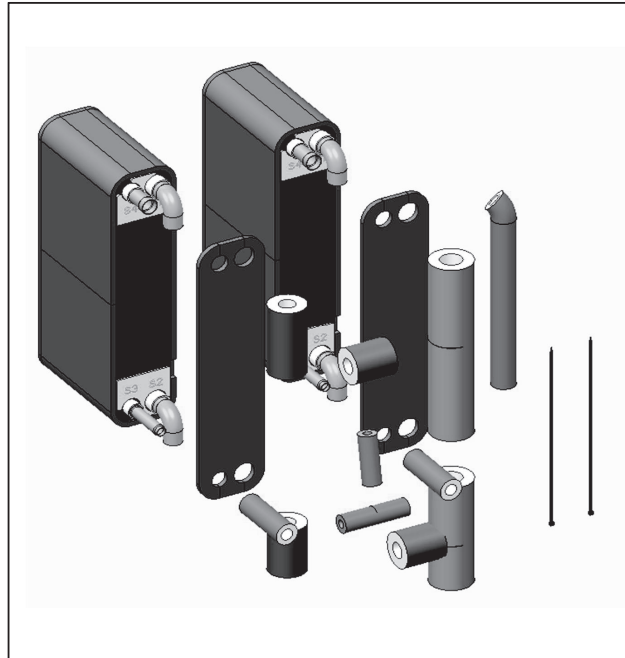

4. Procedures

***Precautions for starting replacement**

- Check that the main power supply is OFF.
- Check that no refrigerant is in the heat source unit.

Remove each part according to the 1)-4) procedures before replacing service parts.

Mount the removed parts back in place in a reversed procedures of 1)-4) after replacing service parts.

1) To remove the control box and the wire

① Remove the screw that is fixed to the Service Panel (total 17 places), and remove the Service Panel (Front Panel).

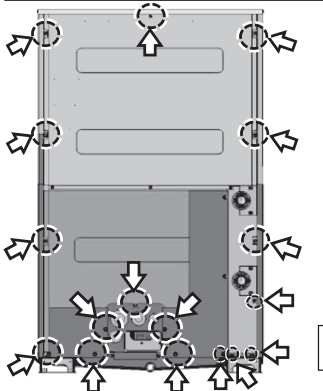

④ Remove the control box.

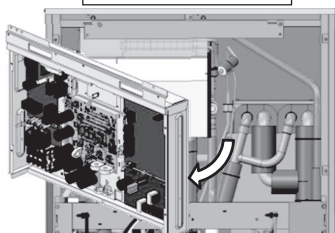

② Disconnect the wiring from the circuit board as shown in the figure.

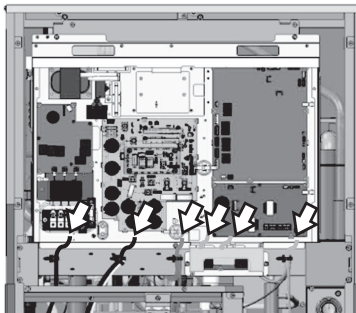

⑤ Remove the pipe cover and cable tie (total 3 places), and then disconnect the wire and sensor (TH7, TH8).

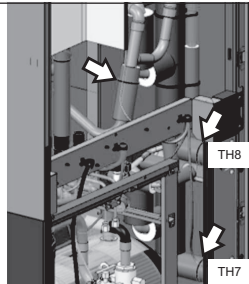

③ Remove the screw that is fixed to the I/O box (total 2 places), and remove the I/O box.

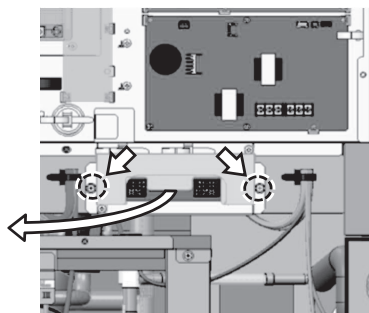

⑥ Remove the wire from cable strap on the Frame M.

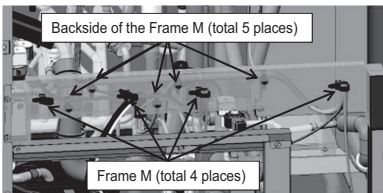

2) To remove the Frame M

①Remove the screw. (total 4 places)

②Turn Frame M Right Side, Pull out.

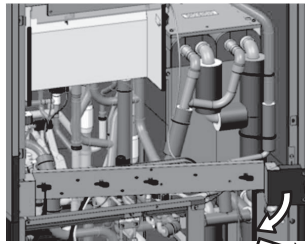
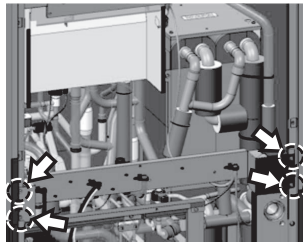

After removing Frame M.

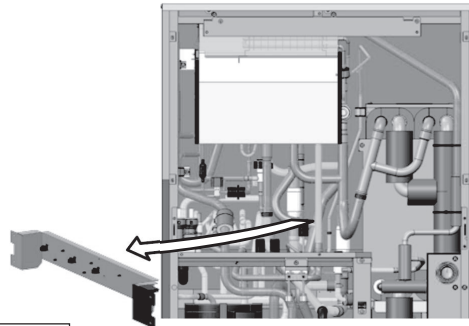

3) To remove the pipe cover

①Remove the pipe cover. (total 11 places)

②Remove the Screw. (total 2 places)

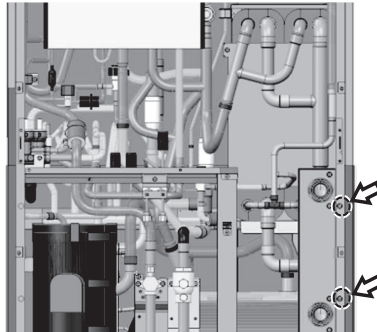
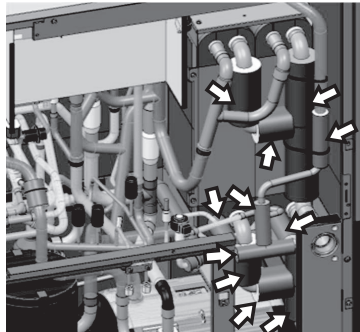

4) To remove the pipe from the Water Heat Exchanger

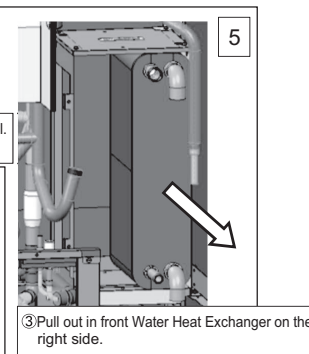
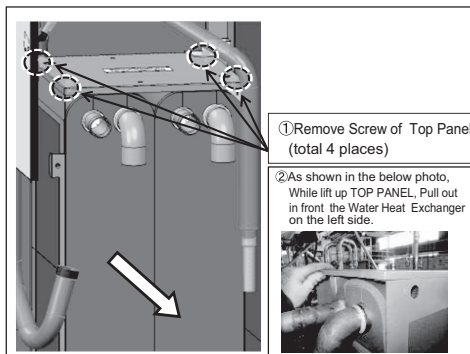
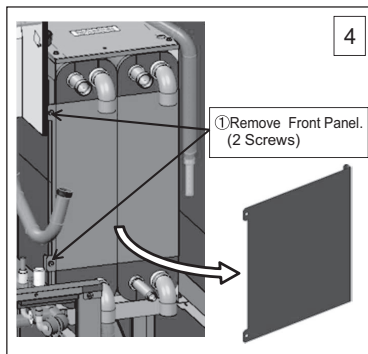
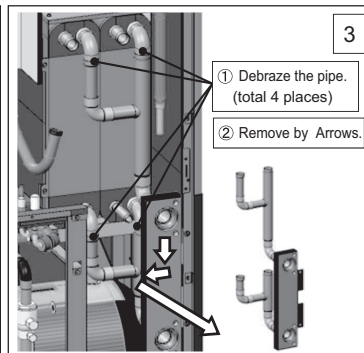
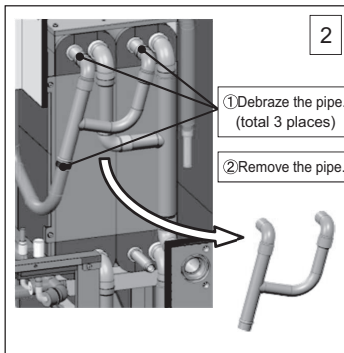
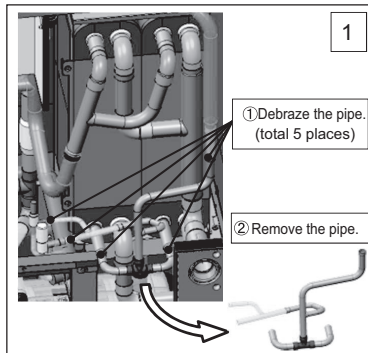

* Precautions for brazing

- Be sure to perform no-oxidation brazing when brazing.
- After brazing, check the condition around the brazing. After confirming no leakage, evacuate the air inside.
- Perform brazing with care of the flame direction so that it does not burn cables and plates etc. in the unit.

[8] Servicing the BC controller

1. Service panel

*Special care must be taken when replacing heavy parts.

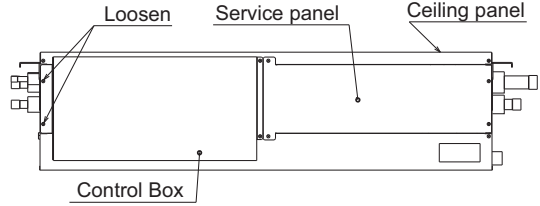
Work procedure	Explanatory figure
<ol style="list-style-type: none"> 1) Remove the two lock nuts on the control box, loosen the other two, and remove the control box. 2) Remove the three fixing screws on the service panel, and remove the service panel. 3) Remove the nine machine screws on the ceiling panel, and remove the ceiling panel. 	 <p>The diagram shows a side view of the BC controller assembly. It consists of three main sections: a 'Control Box' at the bottom, a 'Service panel' in the middle, and a 'Ceiling panel' at the top. Arrows point to the control box with the label 'Loosen', and to the service and ceiling panels with their respective labels.</p>

2. Control box

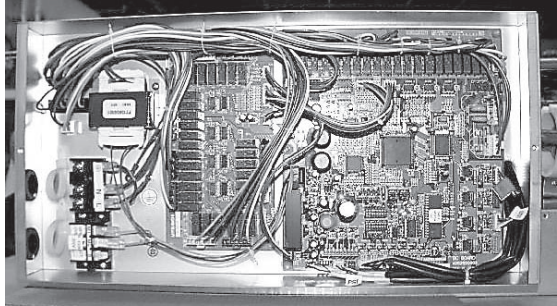
Work procedure	Explanatory figure
<p>(1) To check the inside of the control box, remove the two lock nuts on the control box cover.</p> <ol style="list-style-type: none"> 1) Check the terminal connection of the power wire or of the transmission line. 2) Check the transformer. 3) Check the address switch. <p>(2) When the control board is replaced, the followings must be noted.</p> <ol style="list-style-type: none"> (1) Check that the board type is G,GA (HA), or GB (HB). (2) Check that the wire and the connector are properly connected. <p>Note</p> <p>It is not required to remove the two fixing screws on the control box when checking the inside.</p>	 <p>The photograph shows the interior of the control box. It features a large printed circuit board (PCB) populated with numerous electronic components, including integrated circuits, capacitors, and resistors. A dense network of wires and cables is connected to the board. The components are organized in a structured manner, typical of industrial control equipment.</p> <p style="text-align: center;">CMB-1016NU-G1, GA1, HA1</p>

3. Thermistor (liquid pipe/gas pipe temperature detection)

*Special care must be taken when replacing heavy parts.

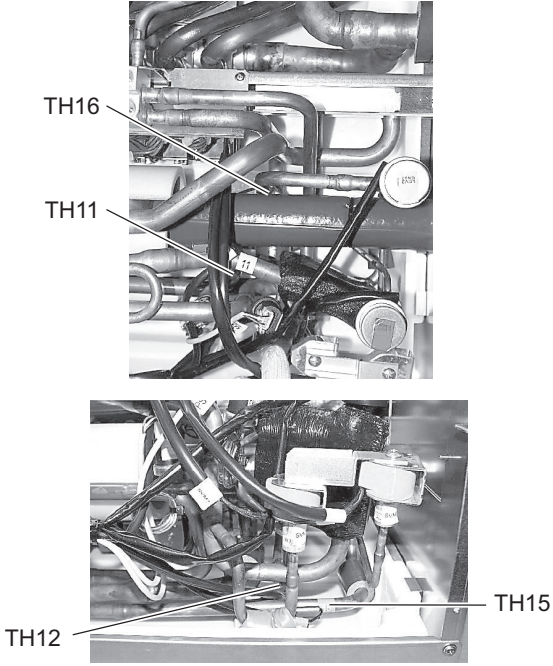
Work procedure	Explanatory figure
<p>(1) Remove the service panel.</p> <p>1) For TH11, TH12, and TH15, refer to 1. 1), 2). 2) For TH16, refer to 1. 1), 2), 3). (GA type only)</p> <p>(2) Remove the lead wire of the piping sensor from the control board.</p> <p>1) TH11, TH12 (CN10) 2) TH15, TH16 (CN11)</p> <p>(3) Pull out the temperature sensor from the temperature sensor housing, and replace the temperature sensor with the new one.</p> <p>(4) Connect the lead wire of the temperature sensor securely on the control board.</p>	 <p style="text-align: center;">CMB-1016NU-GA1</p>

4. Pressure sensor

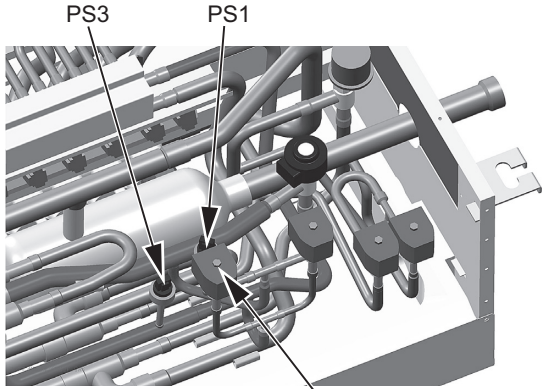
Work procedure	Explanatory figure
<p>(1) Remove the service panel.</p> <p>1) For the pressure sensors PS1 and PS3, refer to 1. 1), 2).</p> <p>(2) Remove the pressure sensor connector in trouble from the control board, and insulate the connector.</p> <p>1) Liquid-side pressure sensor (CNP1) 2) Intermediate-part pressure sensor (CNP3)</p> <p>(3) Attach a new pressure sensor to the place which is shown in the figure, and insert the connector to the control board.</p> <p>Note When gas leaks from the pressure sensor, repair the leak, and follow the instructions above if required.</p>	

5. LEV

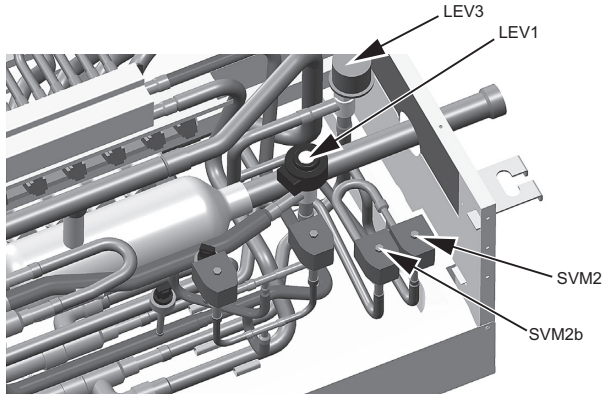
Work procedure	Explanatory figure
<p>(1) Remove the service panel. (See figure at right.) (2) Replace the LEV in trouble.</p> <p>Note Secure enough service space in the ceiling for welding operation, and conduct the work carefully. If required, dismount the unit from the ceiling, and conduct the work.</p>	 <p>LEV3 LEV1 SVM2 SVM2b</p>

6. Solenoid valve

*Special care must be taken when replacing heavy parts.

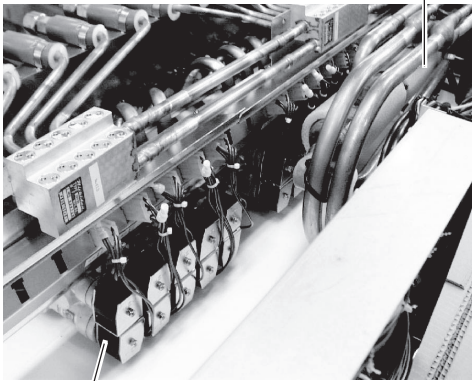
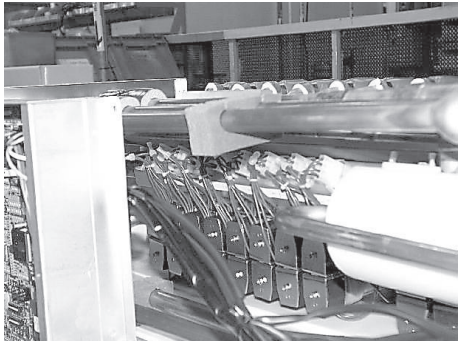
Work procedure	Explanatory figure
<p>(1) Remove the service panel. (See figure at right.) (2) Remove the connector of the solenoid valve in trouble. (3) Remove the solenoid valve coil.</p> <p>1) The coils on the solenoid valves SVA, SVB, SVM1, SVM1b, SVM2, and SVM2b can be serviced through the inspection door. SVC is accessible for replacement by removing the four mounting screws on the rear panel and removing the panel (if enough space is available on the back). (SVM1 is present only on the G, GA, and HA types, SVM2 on the GA and HA types, and SVM1b and SVM2b on the HA type.)</p>	<p>Double-pipe heat exchanger</p>  <p>Solenoid valve</p> <p>CMB-1016NU-G1</p>  <p>CMB-1016NU-GA1</p>

[9] Troubleshooting Using the Heat source Unit LED Error Display

If the LED error display appear as follows while all the slide switches of SW4 are set to OFF, and SW6-10 is set to OFF, check the items under the applicable item numbers below.

1. Error code appears on the LED display.

Refer to IX [2] Responding to Error Display on the Remote Controller.

2. LED is blank.

Take the following troubleshooting steps.

- (1) If the voltage between pins 1 and 3 of CNDC on the control board is outside the range between 220 VDC and 380 VDC, refer to IX [4] -7- (2) Troubleshooting transmission power circuit of heat source unit.**
- (2) If the LED error display becomes lit when the power is turned on with all the connectors on the control board except CNDC disconnected, there is a problem with the wiring to those connectors or with the connectors themselves.**
- (3) If nothing appears on the display under item (2) above AND the voltage between pins 1 and 3 of CNDC is within the range between 220 VDC and 380 VDC, control board failure is suspected.**

3. Only the software version appears on the LED display.

(1) Only the software version appears while the transmission cables to TB3 and TB7 are disconnected.

- 1) Wiring failure between the control board and the transmission line power supply board. (CN62, CNPS, CNIT, CNS2, CN102)
- 2) If item 1) checks out OK, the transmission line power supply board failure is suspected.
- 3) If items 1) and 2) check out OK, control board failure is suspected.

(2) If the LED display appears as noted in "X [1] 2. LED display at Initial setting" while the transmission cables to TB3 and TB7 are disconnected, failure with the transmission cable or the connected equipment is suspected.

X LED Monitor Display on the Heat source Unit Board

[1] How to Read the LED on the Service Monitor	427
--	-----



[1] How to Read the LED on the Service Monitor

1. How to read the LED

By setting the DIP SW 4-1 through 4-10 (SW6-10: OFF) (Switch number 10 is represented by 0), the operating condition of the unit can be monitored on the service monitor. (Refer to the table on the following pages for DIP SW settings.)
The service monitor uses 4-digit 7-segment LED to display numerical values and other types of information.

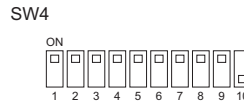
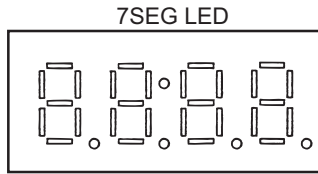

- SW4-10 is represented as "0" in the table.
- In the example above, 1 through 9 are set to ON, and 10 is set to OFF.

Pressure and temperature display are examples of numerical values, and operating conditions and the on-off status of solenoid valve are examples of flag display.

1) Display of numerical values

Example: When the pressure data sensor reads 18.8kg/cm² (Item No. 58)

- The unit of pressure is in kg/cm²
- Use the following conversion formula to convert the displayed value into a value in SI unit.
Value in SI unit (MPa) = Displayed value (kg/cm²) x 0.098

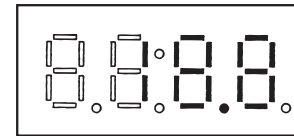

2) Flag display

Example: When 21S4a, 21S4b, SV1a are ON. (Item No. 3)

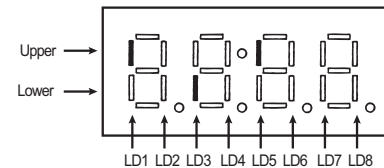

Example: 3-minutes restart mode (Item No. 14)

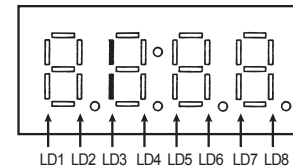

2. LED display at initial setting

From power on until the completion of initial settings, the following information will be displayed on the monitor screen. (Displays No. 1 through No. 4 in order repeatedly.)

No	Item	Display	Remarks
1	Software version	0103	[0103] : Version 1.03
2	Refrigerant type	[410]	[410] : R410A
3	Model and capacity	[H-20]	[H-20] : Cooling/Heating 20 HP For the first few minutes after power on, the capacity of each heat source unit is displayed. Thereafter, the combined capacity is displayed.
4	Communication address	[51]	[51] : Address 51

After the initial settings have been completed, the information on these items can be checked by making the switch setting that corresponds to No. 517 in the LED display table.

Note

Only item No. 1 "Software Version" appears on the display if there is a wiring failure between the control board and the transmission line power supply board or if the circuit board has failed.

•How to convert HP capacity to Model name /Ton

HP capacity is the capacity of outdoor unit that is shown on LED display at initial setting. Please refer to the following table to convert from HP capacity to Model name/Ton.

HP	Model	Ton	HP	Model	Ton
8	P72	6.0	24	P240	20.0
10	P96	8.0	28	P264	22.0
12	P120	10.0	30	P288	24.0
16	P144	12.0	32	P312	26.0
18	P168	14.0	34	P336	28.0
20	P192	16.0	36	P360	30.0
22	P216	18.0			

3. Time data storage function

The heat source unit has a simple clock function that enables the unit to calculate the current time with an internal timer by receiving the time set by the system controller, such as AG-150A. If an error (including a preliminary error) occurs, the error history data and the error detection time are stored into the service memory. The error detection time stored in the service memory and the current time can be seen on the service LED.

Note

- 1) Use the time displayed on the service LED as a reference.
- 2) The date and the time are set to "00" by default. If a system controller that sets the time, such as AG-150A is not connected, the elapsed time and days since the first power on will be displayed. If the time set on a system controller is received, the count will start from the set date and the time.
- 3) The time is not updated while the power of the heat source unit is turned off. When the power is turned off and then on again, the count will resume from the time before the power was turned off. Thus, the time that differs the actual time will be displayed. (This also applies when a power failure occurs.)

The system controller, such as AG-150A, adjusts the time once a day. When the system controller is connected, the time will be automatically updated to the correct current time after the time set by the system controller is received. (The data stored into the memory before the set time is received will not be updated.)

(1) Reading the time data:

- 1) Time display

Example: 12 past 9



* Disappears if the time data is deviated due to a power failure, or if a system controller that sets the time is not connected.

- 2) Date display

•When the main controller that can set the time is connected
Example: May 10, 2003

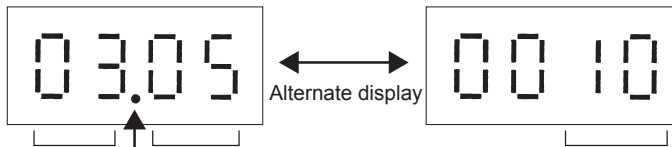

Alternate display of year and month, and date

* Appears between the year and the month, and nothing appears when the date is displayed.

•When the main controller that can set the time is not connected
Example: 52 days after power was turned on



Day count

* Appears between the year and the month, and nothing appears when the date is displayed.

LED monitor display

Current data

No.	SW4 1-10 [0: OFF, 1: ON] (SW6-10: OFF)	Item	Display								Unit (A, B) ^{*1}		Remarks			
			LD1	LD2	LD3	LD4	LD5	LD6	LD7	LD8	OC	OS				
0	0000000000	Relay output display 1 Lighting	Comp in operation									OC	A	A		
		Check (error) display 1 OC/OS error	0000 to 9999 (Address and error codes highlighted)													
1	1000000000	Check (error) display 2 OC/OS error	0000 to 9999 (Address and error codes highlighted)													
2	0100000000	Check (error) display 3 (Including IC and BC)	0000 to 9999 (Address and error codes highlighted)													
3	1100000000	Relay output display 2 Top	21S4a					SV1a						A	A	
		Relay output display 2 Bottom		CH11	21S4b											
4	0010000000	Relay output display 3 Top	SV4a						SV4d			SV9		A	A	
		Relay output display 3 Bottom	SV7a				SV7c									
7	1110000000	Special control	Retry operation	Emergency operation								Communication error between the OC and OS		B	B	
9	1001000000	Communication demand capacity	0000 to 9999													
10	0101000000	Contact point demand capacity	0000 to 9999													
11	1101000000	External signal (Open input contact point)	Contact point demand	Low-noise mode (Capacity priority)	Cooling-heating changeover (Cooling)	Cooling-heating changeover (Heating)								A	A	

*1 A: The condition of either OC or OS is displayed individually. B: The condition of the entire refrigerant system is displayed.

Current data

No.	SW4 1-10 [0: OFF, 1: ON] (SW6-10: OFF)	Item	Display								Unit (A, B) ^{*1}		Remarks		
			LD1	LD2	LD3	LD4	LD5	LD6	LD7	LD8	OC	OS			
12	1234567890	External signal (Open input contact point)											A	A	
14	0111000000	Heat source unit opera- tion status	BC opera- tion signal		3-minutes restart mode	Compressor in operation	Preliminary error	Error	3-minutes restart after instanta- neous power failure	Preliminary low pres- sure error			A	A	
15	1111000000	OC/OS identification	OC/OS								A	A			
16	0000100000	Indoor unit check	Top	Unit No. 1	Unit No. 2	Unit No. 3	Unit No. 4	Unit No. 5	Unit No. 6	Unit No. 7	Unit No. 8		B		The lamp that corre- sponds to the unit that came to an abnormal stop lights. The lamp goes off when the error is reset. Each unit that comes to an abnormal unit will be given a sequential num- ber in ascending order starting with 1.
17	1000100000		Bottom	Unit No. 9	Unit No. 10	Unit No. 11	Unit No. 12	Unit No. 13	Unit No. 14	Unit No. 15	Unit No. 16	Unit No. 17			
18	0100100000	Top	Unit No. 17	Unit No. 18	Unit No. 19	Unit No. 20	Unit No. 21	Unit No. 22	Unit No. 23	Unit No. 24	Unit No. 25				
19	0100100000	Bottom	Unit No. 25	Unit No. 26	Unit No. 27	Unit No. 28	Unit No. 29	Unit No. 30	Unit No. 31	Unit No. 32	Unit No. 33				
20	0010100000	Top	Unit No. 33	Unit No. 34	Unit No. 35	Unit No. 36	Unit No. 37	Unit No. 38	Unit No. 39	Unit No. 40	Unit No. 41				
21	1010100000	Bottom	Unit No. 41	Unit No. 42	Unit No. 43	Unit No. 44	Unit No. 45	Unit No. 46	Unit No. 47	Unit No. 48	Unit No. 49				
22	0110100000	Top	Unit No. 49	Unit No. 50											
23	1110100000	Bottom													
20	0010100000	Indoor unit Operation mode	Top	Unit No. 1	Unit No. 2	Unit No. 3	Unit No. 4	Unit No. 5	Unit No. 6	Unit No. 7	Unit No. 8		B		Lit during cooling Lit during heating Unit while the unit is stopped or in the fan mode
21	1010100000		Bottom	Unit No. 9	Unit No. 10	Unit No. 11	Unit No. 12	Unit No. 13	Unit No. 14	Unit No. 15	Unit No. 16	Unit No. 17			
22	0110100000		Top	Unit No. 17	Unit No. 18	Unit No. 19	Unit No. 20	Unit No. 21	Unit No. 22	Unit No. 23	Unit No. 24	Unit No. 25			
23	1110100000		Bottom	Unit No. 25	Unit No. 26	Unit No. 27	Unit No. 28	Unit No. 29	Unit No. 30	Unit No. 31	Unit No. 32	Unit No. 33			
24	0110100000		Top	Unit No. 33	Unit No. 34	Unit No. 35	Unit No. 36	Unit No. 37	Unit No. 38	Unit No. 39	Unit No. 40	Unit No. 41			
25	1010100000		Bottom	Unit No. 41	Unit No. 42	Unit No. 43	Unit No. 44	Unit No. 45	Unit No. 46	Unit No. 47	Unit No. 48	Unit No. 49			
26	0010100000		Top	Unit No. 49	Unit No. 50										
27	1110100000		Bottom												

*1 A: The condition of either OC or OS is displayed individually. B: The condition of the entire refrigerant system is displayed.

Current data

No.	SW4 1-10 [0: OFF, 1: ON] (SW6-10: OFF)	Item	Display										Unit (A, B) *1		Remarks
			LD1	LD2	LD3	LD4	LD5	LD6	LD7	LD8	OC	OS			
24	0001100000	Indoor unit thermostat	Unit No. 1	Unit No. 2	Unit No. 3	Unit No. 4	Unit No. 5	Unit No. 6	Unit No. 7	Unit No. 8	B		Lit when thermostat is on Unlit when thermostat is off		
		Top	Unit No. 9	Unit No. 10	Unit No. 11	Unit No. 12	Unit No. 13	Unit No. 14	Unit No. 15	Unit No. 16					
25	1001100000	Indoor unit thermostat	Unit No. 17	Unit No. 18	Unit No. 19	Unit No. 20	Unit No. 21	Unit No. 22	Unit No. 23	Unit No. 24					
		Top	Unit No. 25	Unit No. 26	Unit No. 27	Unit No. 28	Unit No. 29	Unit No. 30	Unit No. 31	Unit No. 32					
26	0101100000	Indoor unit thermostat	Unit No. 33	Unit No. 34	Unit No. 35	Unit No. 36	Unit No. 37	Unit No. 38	Unit No. 39	Unit No. 40					
		Bottom	Unit No. 41	Unit No. 42	Unit No. 43	Unit No. 44	Unit No. 45	Unit No. 46	Unit No. 47	Unit No. 48					
27	1101100000	Indoor unit thermostat	Unit No. 49	Unit No. 50											
		Top													
37	1010010000	BC operation mode	Cooling-only ON	Cooling-only OFF	Heating-only ON	Heating-only OFF	Mixed-mode ON	Mixed-mode OFF	Fan	Stop	B				
		Bottom													
39	1110010000	Heat source unit operation mode	Permissible stop	Standby	Cooling	Cooling-main	Heating	Heating-main			A	A			
42	0101010000	Heat source unit control mode	Stop	Thermo OFF	Abnormal stop	Scheduled control	Initial start up	Defrost	Oil balance	Low frequency oil recovery	A	A			
43	1101010000		Warm-up mode	Refrigerant recovery							A	A			
45	1011010000	TH4			-99.9 to 999.9						A	A	The unit is [°C]		
46	0111010000	TH3			-99.9 to 999.9						A	A			
47	1111010000	TH7			-99.9 to 999.9						A	A			
48	0000110000	TH6			-99.9 to 999.9						A	A			
49	1000110000	TH2			-99.9 to 999.9						A	A			
50	0100110000	TH5			-99.9 to 999.9						A	A			
51	1100110000	TH8			-99.9 to 999.9						A	A			
53	1010110000	TH1V			-99.9 to 999.9						A	A	Unit in [°C]		
56	0001110000	THHS1			-99.9 to 999.9						A	A	The unit is [°C]		
58	0101110000	High-pressure sensor data			-99.9 to 999.9						A	A	The unit is [kgf/cm ²]		
59	1101110000	Low-pressure sensor data			-99.9 to 999.9						A	A			

*1 A: The condition of either OC or OS is displayed individually. B: The condition of the entire refrigerant system is displayed.

Current data

No.	SW4 1-10 [0: OFF, 1: ON] (SW6-10: OFF)	Item	Display								Unit (A, B)*1		Remarks
			LD1	LD2	LD3	LD4	LD5	LD6	LD7	LD8	OC	OS	
78	0111001000	Σ Qj	0000 to 9999								B	B	
79	1111001000	Σ Qjc	0000 to 9999								B	B	
80	0000101000	Σ Qjh	0000 to 9999								B	B	
81	1000101000	Target Tc	-99.9 to 999.9								B		The unit is [°C]
82	0100101000	Target Te	-99.9 to 999.9								B		
83	1100101000	Tc	-99.9 to 999.9								A	A	
84	0010101000	Te	-99.9 to 999.9								A	A	
86	0110101000	Total frequencies (OC+OS)	0000 to 9999								B		Control data [Hz]
87	1110101000	Total frequency of each unit	0000 to 9999								A	A	
88	0001101000	COMP frequency	0000 to 9999								A	A	
91	1101101000	Comp operating fre- quency	0000 to 9999								A	A	Unit in [rps] The inverter output current (voltage) frequency will equal the integer multiples of the operating frequency of the compressor.
92	0011101000	Number of times error occurred during IH crankcase heating by compressor motor	0000 to 9999								A	A	Number of times INV er- ror occurred during IH crankcase heating by compressor motor
93	1011101000	All AK (OC+OS)	0000 to 9999								B		
94	0111101000	AK	0000 to 9999								A	A	
99	1100011000	LEV6	0000 to 9999								A	A	Heat source unit LEV opening (Fully open: 1400)
100	0010011000	LEV7	0000 to 9999								A	A	Heat source unit LEV opening (Fully open: 1400)
102	0110011000	LEVINV	0 to 480								A	A	Heat source unit LEV opening (Fully open: 480)

*1 A: The condition of either OC or OS is displayed individually. B: The condition of the entire refrigerant system is displayed.

Current data

No.	SW4 1-10 [0: OFF, 1: ON] (SW6-10: OFF)	Item	Display								Unit (A, B) *1		Remarks
			LD1	LD2	LD3	LD4	LD5	LD6	LD7	LD8	OC	OS	
103	1110011000	LEV1	0 to 480								A	A	Heat source unit LEV opening (Fully open: 480)
108	0011011000	COMP operating current (DC)	00.0 to 999.9								A	A	Peak value[A]
111	1111011000	COMP bus voltage	00.0 to 999.9								A	A	The unit is [V]
116	0010111000	Number of times the unit went into the mode to remedy wet vapor suction	0000 to 9999								B		
117	1010111000	COMP Operation time Upper 4 digits	0000 to 9999								A	A	The unit is [h]
118	0110111000	COMP Operation time Lower 4 digits	0000 to 9999								A	A	
121	1001111000	Backup mode	Abnormal pressure rise	High-pressure drop	Low-pressure drop	Abnormal Td rise	Control box temperature rise						Stays lit for 90 seconds after the completion of backup control
123	1101111000	COMP number of start-stop events Upper 4 digits	0000 to 9999								A	A	Count-up at start-up The unit is [Time]
124	0011111000	COMP number of start-stop events Lower 4 digits	0000 to 9999								A	A	
129	1000000100	Integrated operation time of compressor (for rotation purpose)	0000 to 9999								B		The unit is [h]

*1 A: The condition of either OC or OS is displayed individually. B: The condition of the entire refrigerant system is displayed.

No.	SW4 1-10 [0: OFF, 1: ON] (SW6-10: OFF)	Item	Display															Unit (A, B)*1		Remarks
			LD1	LD2	LD3	LD4	LD5	LD6	LD7	LD8	OC	OS								
132	0010000100	Relay out-put display BC(Main) Top	SVM1	SVM2	SVM1b	SVM2b												B		
133	1010000100	Top	SVA1	SVB1	SVC1	SVA2	SVB2	SVC2										B		
134	0110000100	Bottom	SVA3	SVB3	SVC3	SVA4	SVB4	SVC4										B		
135	1110000100	Top	SVA5	SVB5	SVC5	SVA6	SVB6	SVC6										B		
136	0001000100	Bottom	SVA7	SVB7	SVC7	SVA8	SVB8	SVC8										B		
138	0101000100	Top	SVA9	SVB9	SVC9	SVA10	SVB10	SVC10										B		
139	1101000100	Bottom	SVA11	SVB11	SVC11	SVA12	SVB12	SVC12										B		
140	0011000100	Top	SVA13	SVB13	SVC13	SVA14	SVB14	SVC14										B		
141	1011000100	Bottom	SVA15	SVB15	SVC15	SVA16	SVB16	SVC16										B		
143	1111000100	Relay out-put display BC(Sub1) Top	SVA1	SVB1	SVC1	SVA2	SVB2	SVC2										B		
144	0000100100	Bottom	SVA3	SVB3	SVC3	SVA4	SVB4	SVC4										B		
145	1000100100	Top	SVA5	SVB5	SVC5	SVA6	SVB6	SVC6										B		
146	0100100100	Bottom	SVA7	SVB7	SVC7	SVA8	SVB8	SVC8										B		

*1 A: The condition of either OC or OS is displayed individually. B: The condition of the entire refrigerant system is displayed.

Current data

No.	SW4 1-10 [0: OFF, 1: ON] (SW6-10: OFF)	Item	Display								Unit (A, B) *1		Remarks	
			LD1	LD2	LD3	LD4	LD5	LD6	LD7	LD8	OC	OS		
149	1010100100	BC(Main) or standard) TH11				-99.9 to 999.9						B		
150	0110100100	BC(Main)TH12				-99.9 to 999.9						B		
151	1110100100	BC(Main)TH15				-99.9 to 999.9						B		
152	0001100100	BC(Main)TH16				-99.9 to 999.9						B		
153	1001100100	BC(Main)63HS1				-99.9 to 999.9						B		
154	0101100100	BC(Main)63HS3				-99.9 to 999.9						B		
155	1101100100	BC(Main)SC11				-99.9 to 999.9						B		
156	0011100100	BC(Main)SH12				-99.9 to 999.9						B		
157	1011100100	BC(Main)SH13				-99.9 to 999.9						B		
158	0111100100	BC(Main)SC16				-99.9 to 999.9						B		
159	1111100100	BC(Main)LEV1				0000 to 2000						B		LEV1 opening (Fully open:2000)
160	0000010100	BC(Main)LEV3				0000 to 2000						B		LEV3 opening (Fully open:2000)
161	1000010100	BC(Sub1)TH22				-99.9 to 999.9						B		
162	0100010100	BC(Sub1)TH25				-99.9 to 999.9						B		
163	1100010100	BC(Sub1)LEV3				0000 to 2000						B		LEV3a opening (Fully open:2000)
164	0010010100	BC(Sub2)TH22				-99.9 to 999.9						B		
165	1010010100	BC(Sub2)TH25				-99.9 to 999.9						B		
166	0110010100	BC(Sub2)LEV3				0000 to 2000						B		LEV3a opening (Fully open:2000)
167	1110010100	BC(Main)LEV2				0000 to 2000						B		LEV2 opening (Fully open:2000)

*1 A: The condition of either OC or OS is displayed individually. B: The condition of the entire refrigerant system is displayed.

Current data

No.	SW4 1-10 [0: OFF, 1: ON] (SW6-10: OFF)	Item	Display								Unit (A, B) ^{*1}		Remarks		
			LD1	LD2	LD3	LD4	LD5	LD6	LD7	LD8	OC	OS			
178	0100110100	Error history 1					0000 to 9999						B	B	Address and error codes highlighted if no errors are detected, "----" appears on the display. Preliminary error information of the OS does not appear on the OC. Neither preliminary error information of the OC nor error information of the IC appears on the OS.
179	1100110100	Error details of inverter					Error details of inverter (0001-0120)						A	A	
180	0010110100	Error history 2					0000 to 9999						B	B	
181	1010110100	Error details of inverter					Error details of inverter (0001-0120)						A	A	
182	0110110100	Error history 3					0000 to 9999						B	B	
183	1110110100	Error details of inverter					Error details of inverter (0001-0120)						A	A	
184	0001110100	Error history 4					0000 to 9999						B	B	
185	1001110100	Error details of inverter					Error details of inverter (0001-0120)						A	A	
186	0101110100	Error history 5					0000 to 9999						B	B	
187	1101110100	Error details of inverter					Error details of inverter (0001-0120)						A	A	
188	0011110100	Error history 6					0000 to 9999						B	B	
189	1011110100	Error details of inverter					Error details of inverter (0001-0120)						A	A	
190	0111110100	Error history 7					0000 to 9999						B	B	
191	1111110100	Error details of inverter					Error details of inverter (0001-0120)						A	A	
192	000001100	Error history 8					0000 to 9999						B	B	
193	100001100	Error details of inverter					Error details of inverter (0001-0120)						A	A	
194	010001100	Error history 9					0000 to 9999						B	B	
195	110001100	Error details of inverter					Error details of inverter (0001-0120)						A	A	
196	0010001100	Error history 10					0000 to 9999						B	B	
197	1010001100	Error details of inverter					Error details of inverter (0001-0120)						A	A	
198	0110001100	Error history of inverter (At the time of last data backup before error)					0000 to 9999						B	B	
199	1110001100	Error details of inverter					Error details of inverter (0001-0120)						A	A	

*1 A: The condition of either OC or OS is displayed individually. B: The condition of the entire refrigerant system is displayed.

Error history

No.	SW4 1-10 [0: OFF, 1: ON] (SW6-10: OFF)	Item	Display									Unit (A, B) ^{*1}		Remarks
			LD1	LD2	LD3	LD4	LD5	LD6	LD7	LD8	OC	OS		
201	1001001100	Heat source unit operation status	BC operation signal	Warm-up mode	3-minutes restart mode	Compressor in operation	Preliminary error	Error	3-minutes restart after instantaneous power failure	Preliminary low pressure error	A	A		
202	0101001100	OC/OS identification	OC/OS-1/OS-2									A	A	
203	1101001100	BC operation mode	Cooling-only ON	Cooling-only OFF	Heating-only ON	Heating-only OFF	Mixed-mode ON	Mixed-mode OFF					Stop	
205	1011001100	Heat source unit Operation mode	Permissible stop	Standby	Cooling	Cooling-main	Heating	Heating-main						
208	0000101100	Heat source unit control mode	Stop	Thermo OFF	Abnormal stop	Scheduled control	Initial start up						Low frequency oil recovery	
209	1000101100		Warm-up mode	Refrigerant recovery										
211	1100101100	Relay output display 1 Lighting	Comp in operation				72C						Always lit	
212	0010101100	Relay output display 2 Lighting	21S4a		CH11		SV1a							
				21S4b										
213	1010101100	Relay output display 3 Lighting	SV4a	SV4b				SV4d	SV9					
			SV7a	SV7b	SV7c									

*1 A: The condition of either OC or OS is displayed individually. B: The condition of the entire refrigerant system is displayed.

Error history

No.	SW4 1-10 [0: OFF, 1: ON] (SW6-10: OFF)	Item	Display								Unit (A, B)*1		Remarks		
			LD1	LD2	LD3	LD4	LD5	LD6	LD7	LD8	OC	OS			
216	0001101100	TH4											A	A	The unit is [°C]
217	1001101100	TH3											A	A	
218	0101101100	TH7											A	A	
219	1101101100	TH6											A	A	
220	0011101100	TH2											A	A	
221	1011101100	TH5											A	A	
222	0111101100	TH8											A	A	
224	0000011100	TH1V											A	A	
227	1100011100	THHS1											A	A	The unit is [°C]
229	1010011100	High-pressure sensor data											A	A	The unit is [kgf/cm ²]
230	0110011100	Low-pressure sensor data											A	A	
249	1001111100	Σ Qj											B	B	
250	0101111100	Σ Qjc											B	B	
251	1101111100	Σ Qjh											B	B	
252	0011111100	Target Tc											B		The unit is [°C]
253	1011111100	Target Te											B		
254	0111111100	Tc											A	A	The unit is [°C]
255	1111111100	Te											A	A	
257	1000000010	Total frequencies (OC+OS)											B		Control data [Hz]
258	0100000010	Total frequency of each unit											A	A	
259	1100000010	COMP frequency											A	A	
262	0110000010	Comp operating frequency											A	A	Unit in [rps]
264	0001000010	All AK (OC+OS)											B		
265	1001000010	AK											A	A	

*1 A: The condition of either OC or OS is displayed individually. B: The condition of the entire refrigerant system is displayed.

Error history

No.	SW4 1-10 [0: OFF, 1: ON] (SW6-10: OFF)	Item	Display								Unit (A, B) ^{*1}		Remarks
			LD1	LD2	LD3	LD4	LD5	LD6	LD7	LD8	OC	OS	
270	0111000010	LEV6	0000 to 9999								A	A	Heat source unit LEV opening (Fully open: 1400)
271	1111000010	LEV7	0000 to 9999								A	A	Heat source unit LEV opening (Fully open: 1400)
273	1000100010	LEVINV	0 to 480								A	A	Heat source unit LEV opening (Fully open: 480)
274	0100100010	LEV1	0 to 480								A	A	Heat source unit LEV opening (Fully open: 480)
279	1110100010	COMP operating current (DC)	00.0 to 999.9								A	A	Peak value [A]
282	0101100010	COMP bus voltage	00.0 to 999.9								A	A	The unit is [V]
288	0000010010	COMP Operation time Upper 4 digits	0000 to 9999								A	A	The unit is [h]
289	1000010010	COMP Operation time Lower 4 digits	0000 to 9999								A	A	
294	0110010010	COMP number of start-stop events Upper 4 digits	0000 to 9999								A	A	Count-up at start-up The unit is [Time]
295	1110010010	COMP number of start-stop events Lower 4 digits	0000 to 9999								A	A	
300	0011010010	Integrated operation time of compressor (for rotation purpose)	0000 to 9999								B		The unit is [h]

*1 A: The condition of either OC or OS is displayed individually. B: The condition of the entire refrigerant system is displayed.

Current data

No.	SW4 1-10 [0: OFF, 1: ON] (SW6-10: OFF)	Item	Display								Unit (A, B) ^{*1}		Remarks
			LD1	LD2	LD3	LD4	LD5	LD6	LD7	LD8	OC	OS	
301	1011010010	Power supply unit	OC/OS-1/OS-2 <-> Address								B		
302	0111010010	Start-up unit	OC/OS-1/OS-2 <-> Address								B		
320	0000001010	BC(Main)TH11	-99.9 to 999.9								B		
321	1000001010	BC(Main)TH12	-99.9 to 999.9								B		
322	0100001010	BC(Main)TH15	-99.9 to 999.9								B		
323	1100001010	BC(Main)TH16	-99.9 to 999.9								B		
324	0010001010	BC(Main)63HS1	-99.9 to 999.9								B		
325	1010001010	BC(Main)63HS3	-99.9 to 999.9								B		
330	0101001010	BC(Main)LEV1	0000 to 2000								B		
331	1101001010	BC(Main)LEV3	0000 to 2000								B		
332	0011001010	BC(Sub1)TH22	-99.9 to 999.9								B		
333	1011001010	BC(Sub1)TH25	-99.9 to 999.9								B		
334	0111001010	BC(Sub1)LEV3	0000 to 2000								B		
335	1111001010	BC(Sub2)TH22	-99.9 to 999.9								B		
336	0000101010	BC(Sub2)TH25	-99.9 to 999.9								B		
337	1000101010	BC(Sub2)LEV3	0000 to 2000								B		
338	0100101010	BC(Main)LEV2	0000 to 2000								B		

*1 A: The condition of either OC or OS is displayed individually. B: The condition of the entire refrigerant system is displayed.

Data on indoor unit system

No.	SW4 1-10 [0: OFF, 1: ON] (SW6-10: OFF)	Item	Display								Unit (A, B) ^{*1}		Remarks		
			LD1	LD2	LD3	LD4	LD5	LD6	LD7	LD8	OC	OS			
351	11111010	IC1 Address/capacity code	0000 to 9999												Displayed alternately every 5 seconds
352	000011010	IC2 Address/capacity code	0000 to 9999												
353	100011010	IC3 Address/capacity code	0000 to 9999												
354	010011010	IC4 Address/capacity code	0000 to 9999												
355	110011010	IC5 Address/capacity code	0000 to 9999												
356	0010011010	IC6 Address/capacity code	0000 to 9999												
357	1010011010	IC7 Address/capacity code	0000 to 9999												
358	0110011010	IC8 Address/capacity code	0000 to 9999												
359	1110011010	IC9 Address/capacity code	0000 to 9999												
360	0001011010	IC10 Address/capacity code	0000 to 9999												
361	1001011010	IC11 Address/capacity code	0000 to 9999												
362	0101011010	IC12 Address/capacity code	0000 to 9999												
363	1101011010	IC13 Address/capacity code	0000 to 9999												
364	0011011010	IC14 Address/capacity code	0000 to 9999												
365	1011011010	IC15 Address/capacity code	0000 to 9999												
366	0111011010	IC16 Address/capacity code	0000 to 9999												
367	1111011010	IC17 Address/capacity code	0000 to 9999												
368	0000111010	IC18 Address/capacity code	0000 to 9999												
369	1000111010	IC19 Address/capacity code	0000 to 9999												
370	0100111010	IC20 Address/capacity code	0000 to 9999												
371	1100111010	IC21 Address/capacity code	0000 to 9999												
372	0010111010	IC22 Address/capacity code	0000 to 9999												
373	1010111010	IC23 Address/capacity code	0000 to 9999												
374	0110111010	IC24 Address/capacity code	0000 to 9999												
375	1110111010	IC25 Address/capacity code	0000 to 9999												
376	0001111010	IC26 Address/capacity code	0000 to 9999												
377	1001111010	IC27 Address/capacity code	0000 to 9999												

*1 A: The condition of either OC or OS is displayed individually. B: The condition of the entire refrigerant system is displayed.

Data on indoor unit system

No.	SW4 1-10 [0: OFF, 1: ON] (SW6-10: OFF)	Item	Display								Unit (A, B)*1		Remarks	
			LD1	LD2	LD3	LD4	LD5	LD6	LD7	LD8	OC	OS		
378	0101111010	IC28 Address/capacity code	0000 to 9999							0000 to 9999			Displayed alternately every 5 seconds	
379	1101111010	IC29 Address/capacity code	0000 to 9999							0000 to 9999				
380	0011111010	IC30 Address/capacity code	0000 to 9999							0000 to 9999				
381	1011111010	IC31 Address/capacity code	0000 to 9999							0000 to 9999				
382	0111111010	IC32 Address/capacity code	0000 to 9999							0000 to 9999				
383	1111111010	IC33 Address/capacity code	0000 to 9999							0000 to 9999				
384	000000110	IC34 Address/capacity code	0000 to 9999							0000 to 9999				
385	100000110	IC35 Address/capacity code	0000 to 9999							0000 to 9999				
386	010000110	IC36 Address/capacity code	0000 to 9999							0000 to 9999				
387	110000110	IC37 Address/capacity code	0000 to 9999							0000 to 9999				
388	001000110	IC38 Address/capacity code	0000 to 9999							0000 to 9999				
389	101000110	IC39 Address/capacity code	0000 to 9999							0000 to 9999				
390	011000110	IC40 Address/capacity code	0000 to 9999							0000 to 9999				
391	111000110	IC41 Address/capacity code	0000 to 9999							0000 to 9999				
392	0001000110	IC42 Address/capacity code	0000 to 9999							0000 to 9999				
393	1001000110	IC43 Address/capacity code	0000 to 9999							0000 to 9999				
394	0101000110	IC44 Address/capacity code	0000 to 9999							0000 to 9999				
395	1101000110	IC45 Address/capacity code	0000 to 9999							0000 to 9999				
396	0011000110	IC46 Address/capacity code	0000 to 9999							0000 to 9999				
397	1011000110	IC47 Address/capacity code	0000 to 9999							0000 to 9999				
398	0111000110	IC48 Address/capacity code	0000 to 9999							0000 to 9999				
399	1111000110	IC49 Address/capacity code	0000 to 9999							0000 to 9999				
400	0000100110	IC50 Address/capacity code	0000 to 9999							0000 to 9999				
408	0001100110	IC1 Suction temperature				-99.9 to 999.9								The unit is [°C]
409	1001100110	IC2 Suction temperature				-99.9 to 999.9								
410	0101100110	IC3 Suction temperature				-99.9 to 999.9								
411	1101100110	IC4 Suction temperature				-99.9 to 999.9								

*1 A: The condition of either OC or OS is displayed individually. B: The condition of the entire refrigerant system is displayed.

Data on indoor unit system

No.	SW4 1-10 [0: OFF, 1: ON] (SW6-10: OFF)	Item	Display								Unit (A, B)*1		Remarks
			LD1	LD2	LD3	LD4	LD5	LD6	LD7	LD8	OC	OS	
412	0011100110	IC5 Suction temperature	-99.9	-99.9	-99.9	-99.9	-99.9	-99.9	-99.9	-99.9	-99.9	B	The unit is [°C]
413	1011100110	IC6 Suction temperature	-99.9	-99.9	-99.9	-99.9	-99.9	-99.9	-99.9	-99.9	-99.9		
414	0111100110	IC7 Suction temperature	-99.9	-99.9	-99.9	-99.9	-99.9	-99.9	-99.9	-99.9	-99.9		
415	1111100110	IC8 Suction temperature	-99.9	-99.9	-99.9	-99.9	-99.9	-99.9	-99.9	-99.9	-99.9		
416	000010110	IC9 Suction temperature	-99.9	-99.9	-99.9	-99.9	-99.9	-99.9	-99.9	-99.9	-99.9		
417	100010110	IC10 Suction temperature	-99.9	-99.9	-99.9	-99.9	-99.9	-99.9	-99.9	-99.9	-99.9		
418	010010110	IC11 Suction temperature	-99.9	-99.9	-99.9	-99.9	-99.9	-99.9	-99.9	-99.9	-99.9		
419	110010110	IC12 Suction temperature	-99.9	-99.9	-99.9	-99.9	-99.9	-99.9	-99.9	-99.9	-99.9		
420	0010010110	IC13 Suction temperature	-99.9	-99.9	-99.9	-99.9	-99.9	-99.9	-99.9	-99.9	-99.9		
421	1010010110	IC14 Suction temperature	-99.9	-99.9	-99.9	-99.9	-99.9	-99.9	-99.9	-99.9	-99.9		
422	0110010110	IC15 Suction temperature	-99.9	-99.9	-99.9	-99.9	-99.9	-99.9	-99.9	-99.9	-99.9		
423	1110010110	IC16 Suction temperature	-99.9	-99.9	-99.9	-99.9	-99.9	-99.9	-99.9	-99.9	-99.9		
424	0001010110	IC17 Suction temperature	-99.9	-99.9	-99.9	-99.9	-99.9	-99.9	-99.9	-99.9	-99.9		
425	1001010110	IC18 Suction temperature	-99.9	-99.9	-99.9	-99.9	-99.9	-99.9	-99.9	-99.9	-99.9		
426	0101010110	IC19 Suction temperature	-99.9	-99.9	-99.9	-99.9	-99.9	-99.9	-99.9	-99.9	-99.9		
427	1101010110	IC20 Suction temperature	-99.9	-99.9	-99.9	-99.9	-99.9	-99.9	-99.9	-99.9	-99.9		
428	0011010110	IC21 Suction temperature	-99.9	-99.9	-99.9	-99.9	-99.9	-99.9	-99.9	-99.9	-99.9		
429	1011010110	IC22 Suction temperature	-99.9	-99.9	-99.9	-99.9	-99.9	-99.9	-99.9	-99.9	-99.9		
430	0111010110	IC23 Suction temperature	-99.9	-99.9	-99.9	-99.9	-99.9	-99.9	-99.9	-99.9	-99.9		
431	1111010110	IC24 Suction temperature	-99.9	-99.9	-99.9	-99.9	-99.9	-99.9	-99.9	-99.9	-99.9		
432	000010110	IC25 Suction temperature	-99.9	-99.9	-99.9	-99.9	-99.9	-99.9	-99.9	-99.9	-99.9		
433	100010110	IC26 Suction temperature	-99.9	-99.9	-99.9	-99.9	-99.9	-99.9	-99.9	-99.9	-99.9		
434	010010110	IC27 Suction temperature	-99.9	-99.9	-99.9	-99.9	-99.9	-99.9	-99.9	-99.9	-99.9		
435	110010110	IC28 Suction temperature	-99.9	-99.9	-99.9	-99.9	-99.9	-99.9	-99.9	-99.9	-99.9		
436	001010110	IC29 Suction temperature	-99.9	-99.9	-99.9	-99.9	-99.9	-99.9	-99.9	-99.9	-99.9		
437	101010110	IC30 Suction temperature	-99.9	-99.9	-99.9	-99.9	-99.9	-99.9	-99.9	-99.9	-99.9		
438	011010110	IC31 Suction temperature	-99.9	-99.9	-99.9	-99.9	-99.9	-99.9	-99.9	-99.9	-99.9		

*1 A: The condition of either OC or OS is displayed individually. B: The condition of the entire refrigerant system is displayed.

Data on indoor unit system

No.	SW4 1-10 [0: OFF, 1: ON] (SW6-10: OFF)	Item	Display								Unit (A, B)*1		Remarks	
			LD1	LD2	LD3	LD4	LD5	LD6	LD7	LD8	OC	OS		
439	1110110110	IC32 Suction temperature												The unit is [°C]
440	0001110110	IC33 Suction temperature												
441	1001110110	IC34 Suction temperature												
442	0101110110	IC35 Suction temperature												
443	1101110110	IC36 Suction temperature												
444	0011110110	IC37 Suction temperature												
445	1011110110	IC38 Suction temperature												
446	0111110110	IC39 Suction temperature												
447	1111110110	IC40 Suction temperature												
448	000001110	IC41 Suction temperature												
449	100001110	IC42 Suction temperature												
450	010001110	IC43 Suction temperature												
451	110001110	IC44 Suction temperature												
452	001001110	IC45 Suction temperature												
453	101001110	IC46 Suction temperature												
454	011001110	IC47 Suction temperature												
455	111001110	IC48 Suction temperature												
456	000100110	IC49 Suction temperature												
457	100100110	IC50 Suction temperature												
458	010100110	IC1 Liquid pipe temperature												
459	110100110	IC2 Liquid pipe temperature												
460	001100110	IC3 Liquid pipe temperature												
461	101100110	IC4 Liquid pipe temperature												
462	011100110	IC5 Liquid pipe temperature												
463	111100110	IC6 Liquid pipe temperature												
464	000010110	IC7 Liquid pipe temperature												
465	100010110	IC8 Liquid pipe temperature												

*1 A: The condition of either OC or OS is displayed individually. B: The condition of the entire refrigerant system is displayed.

Data on indoor unit system

No.	SW4 1-10 [0: OFF, 1: ON] (SW6-10: OFF)	Item	Display										Unit (A, B)*1		Remarks	
			LD1	LD2	LD3	LD4	LD5	LD6	LD7	LD8	OC	OS				
466	0100101110	IC9 Liquid pipe temperature														
467	1100101110	IC10 Liquid pipe temperature														
468	0010101110	IC11 Liquid pipe temperature														
469	1010101110	IC12 Liquid pipe temperature														
470	0110101110	IC13 Liquid pipe temperature														
471	1110101110	IC14 Liquid pipe temperature														
472	0001101110	IC15 Liquid pipe temperature														
473	1001101110	IC16 Liquid pipe temperature														
474	0101101110	IC17 Liquid pipe temperature														
475	1101101110	IC18 Liquid pipe temperature														
476	0011101110	IC19 Liquid pipe temperature														
477	1011101110	IC20 Liquid pipe temperature														
478	0111101110	IC21 Liquid pipe temperature														
479	1111101110	IC22 Liquid pipe temperature														
480	0000111110	IC23 Liquid pipe temperature														
481	1000111110	IC24 Liquid pipe temperature														
482	0100011110	IC25 Liquid pipe temperature														
483	1100011110	IC26 Liquid pipe temperature														
484	0010011110	IC27 Liquid pipe temperature														
485	1010011110	IC28 Liquid pipe temperature														
486	0110011110	IC29 Liquid pipe temperature														
487	1110011110	IC30 Liquid pipe temperature														
488	0001011110	IC31 Liquid pipe temperature														
489	1001011110	IC32 Liquid pipe temperature														
490	0101011110	IC33 Liquid pipe temperature														
491	1101011110	IC34 Liquid pipe temperature														
492	0011011110	IC35 Liquid pipe temperature														

*1 A: The condition of either OC or OS is displayed individually. B: The condition of the entire refrigerant system is displayed.

Data on indoor unit system

No.	SW4 1-10 [0: OFF, 1: ON] (SW6-10: OFF)	Item	Display								Unit (A, B)*1		Remarks		
			LD1	LD2	LD3	LD4	LD5	LD6	LD7	LD8	OC	OS			
493	1234567890	IC36 Liquid pipe temperature													
494	1011011110	IC37 Liquid pipe temperature													
495	0111011110	IC38 Liquid pipe temperature													
496	1111011110	IC39 Liquid pipe temperature													
497	0000111110	IC40 Liquid pipe temperature													
498	1000111110	IC41 Liquid pipe temperature													
499	0100111110	IC42 Liquid pipe temperature													
500	1100111110	IC43 Liquid pipe temperature													
501	0010111110	IC44 Liquid pipe temperature													
502	1010111110	IC45 Liquid pipe temperature													
503	0110111110	IC46 Liquid pipe temperature													
504	0001111110	IC47 Liquid pipe temperature													
505	1001111110	IC48 Liquid pipe temperature													
506	0101111110	IC49 Liquid pipe temperature													
507	1101111110	IC50 Liquid pipe temperature													

*1 A: The condition of either OC or OS is displayed individually. B: The condition of the entire refrigerant system is displayed.

Setting data

No.	SW4 1-10 [0: OFF, 1: ON] (SW6-10: OFF)	Item	Display								Unit (A, B) ^{*1}		Remarks
			LD1	LD2	LD3	LD4	LD5	LD6	LD7	LD8	OC	OS	
512	1234567890	Self-address	Alternate display of self address and unit model								A	A	
513	0000000001	IC/FU address	Count-up display of number of connected units								B		
514	1000000001	RC address	Count-up display of number of connected units								B		
515	0100000001	BC/BS/TU address	Count-up display of number of connected units								B		
516	1100000001	OS address	Count-up display of number of connected units								B		
517	0010000001	Version/Capacity	S/W version -> Refrigerant type -> Model and capacity -> Communication address								A	A	
518	1010000001	OC address	OC address display									B	

*1 A: The condition of either OC or OS is displayed individually. B: The condition of the entire refrigerant system is displayed.

Data on indoor unit system

No.	SW4 1-10 [0: OFF, 1: ON] (SW6-10: OFF)	Item	Display										Unit (A, B) *1		Remarks	
			LD1	LD2	LD3	LD4	LD5	LD6	LD7	LD8	OC	OS				
523	1101000001	IC1 Gas pipe temperature				-99.9 to 999.9									B	The unit is [°C]
524	0011000001	IC2 Gas pipe temperature				-99.9 to 999.9										
525	1011000001	IC3 Gas pipe temperature				-99.9 to 999.9										
526	0111000001	IC4 Gas pipe temperature				-99.9 to 999.9										
527	1111000001	IC5 Gas pipe temperature				-99.9 to 999.9										
528	0000100001	IC6 Gas pipe temperature				-99.9 to 999.9										
529	1000100001	IC7 Gas pipe temperature				-99.9 to 999.9										
530	0100100001	IC8 Gas pipe temperature				-99.9 to 999.9										
531	1100100001	IC9 Gas pipe temperature				-99.9 to 999.9										
532	0010100001	IC10 Gas pipe temperature				-99.9 to 999.9										
533	1010100001	IC11 Gas pipe temperature				-99.9 to 999.9										
534	0110100001	IC12 Gas pipe temperature				-99.9 to 999.9										
535	1110100001	IC13 Gas pipe temperature				-99.9 to 999.9										
536	0001100001	IC14 Gas pipe temperature				-99.9 to 999.9										
537	1001100001	IC15 Gas pipe temperature				-99.9 to 999.9										
538	0101100001	IC16 Gas pipe temperature				-99.9 to 999.9										
539	1101100001	IC17 Gas pipe temperature				-99.9 to 999.9										
540	0011100001	IC18 Gas pipe temperature				-99.9 to 999.9										
541	1011100001	IC19 Gas pipe temperature				-99.9 to 999.9										
542	0111100001	IC20 Gas pipe temperature				-99.9 to 999.9										
543	1111100001	IC21 Gas pipe temperature				-99.9 to 999.9										
544	0000010001	IC22 Gas pipe temperature				-99.9 to 999.9										
545	1000010001	IC23 Gas pipe temperature				-99.9 to 999.9										
546	0100010001	IC24 Gas pipe temperature				-99.9 to 999.9										
547	1100010001	IC25 Gas pipe temperature				-99.9 to 999.9										
548	0010010001	IC26 Gas pipe temperature				-99.9 to 999.9										
549	1010010001	IC27 Gas pipe temperature				-99.9 to 999.9										

*1 A: The condition of either OC or OS is displayed individually. B: The condition of the entire refrigerant system is displayed.

Data on indoor unit system

No.	SW4 1-10 [0: OFF, 1: ON] (SW6-10: OFF)	Item	Display										Unit (A, B) *1		Remarks		
			LD1	LD2	LD3	LD4	LD5	LD6	LD7	LD8	OC	OS					
550	0110010001	IC28 Gas pipe temperature															The unit is [°C]
551	1110010001	IC29 Gas pipe temperature															
552	0001010001	IC30 Gas pipe temperature															
553	1001010001	IC31 Gas pipe temperature															
554	0101010001	IC32 Gas pipe temperature															
555	1101010001	IC33 Gas pipe temperature															
556	0011010001	IC34 Gas pipe temperature															
557	1011010001	IC35 Gas pipe temperature															
558	0111010001	IC36 Gas pipe temperature															
559	1111010001	IC37 Gas pipe temperature															
560	0000110001	IC38 Gas pipe temperature															
561	1000110001	IC39 Gas pipe temperature															
562	0100110001	IC40 Gas pipe temperature															
563	1100110001	IC41 Gas pipe temperature															
564	0010110001	IC42 Gas pipe temperature															
565	1010110001	IC43 Gas pipe temperature															
566	0110110001	IC44 Gas pipe temperature															
567	1110110001	IC45 Gas pipe temperature															
568	0001110001	IC46 Gas pipe temperature															
569	1001110001	IC47 Gas pipe temperature															
570	0101110001	IC48 Gas pipe temperature															
571	1101110001	IC49 Gas pipe temperature															
572	0011110001	IC50 Gas pipe temperature															

*1 A: The condition of either OC or OS is displayed individually. B: The condition of the entire refrigerant system is displayed.

Data on indoor unit system

No.	SW4 1-10 [0: OFF, 1: ON] (SW6-10: OFF)	Item	Display								Unit (A, B)*1		Remarks	
			LD1	LD2	LD3	LD4	LD5	LD6	LD7	LD8	OC	OS		
573	1011110001	IC1SH												The unit is [°C]
574	0111110001	IC2SH												
575	1111110001	IC3SH												
576	000001001	IC4SH												
577	100001001	IC5SH												
578	010001001	IC6SH												
579	110001001	IC7SH												
580	0010001001	IC8SH												
581	1010001001	IC9SH												
582	0110001001	IC10SH												
583	1110001001	IC11SH												
584	0001001001	IC12SH												
585	1001001001	IC13SH												
586	0101001001	IC14SH												
587	1101001001	IC15SH												
588	0011001001	IC16SH												
589	1011001001	IC17SH												
590	0111001001	IC18SH												
591	1111001001	IC19SH												
592	0000101001	IC20SH												
593	1000101001	IC21SH												
594	0100101001	IC22SH												
595	1100101001	IC23SH												
596	0010101001	IC24SH												
597	1010101001	IC25SH												
598	0110101001	IC26SH												
599	1110101001	IC27SH												

*1 A: The condition of either OC or OS is displayed individually. B: The condition of the entire refrigerant system is displayed.

Data on indoor unit system

No.	SW4 1-10 [0: OFF, 1: ON] (SW6-10: OFF)	Item	Display								Unit (A, B) ^{*1}		Remarks	
			LD1	LD2	LD3	LD4	LD5	LD6	LD7	LD8	OC	OS		
600	0001101001	IC28SH												The unit is [°C]
601	1001101001	IC29SH												
602	0101101001	IC30SH												
603	1101101001	IC31SH												
604	0011101001	IC32SH												
605	1011101001	IC33SH												
606	0111101001	IC34SH												
607	1111101001	IC35SH												
608	000011001	IC36SH												
609	100011001	IC37SH												
610	010011001	IC38SH												
611	110011001	IC39SH												
612	0010011001	IC40SH												
613	1010011001	IC41SH												
614	0110011001	IC42SH												
615	1110011001	IC43SH												
616	0001011001	IC44SH												
617	1001011001	IC45SH												
618	0101011001	IC46SH												
619	1101011001	IC47SH												
620	0011011001	IC48SH												
621	1011011001	IC49SH												
622	0111011001	IC50SH												

*1 A: The condition of either OC or OS is displayed individually. B: The condition of the entire refrigerant system is displayed.

Data on indoor unit system

No.	SW4 1-10 [0: OFF, 1: ON] (SW6-10: OFF)	Item	Display								Unit (A, B)*1		Remarks	
			LD1	LD2	LD3	LD4	LD5	LD6	LD7	LD8	OC	OS		
623	1111011001	IC1SC												The unit is [°C]
624	0000111001	IC2SC												
625	1000111001	IC3SC												
626	0100111001	IC4SC												
627	1100111001	IC5SC												
628	0010111001	IC6SC												
629	1010111001	IC7SC												
630	0110111001	IC8SC												
631	1110111001	IC9SC												
632	0001111001	IC10SC												
633	1001111001	IC11SC												
634	0101111001	IC12SC												
635	1101111001	IC13SC												
636	0011111001	IC14SC												
637	1011111001	IC15SC												
638	0111111001	IC16SC												
639	1111111001	IC17SC												
640	000000101	IC18SC												
641	100000101	IC19SC												
642	010000101	IC20SC												
643	110000101	IC21SC												
644	001000101	IC22SC												
645	101000101	IC23SC												
646	011000101	IC24SC												
647	111000101	IC25SC												
648	0001000101	IC26SC												
649	1001000101	IC27SC												

*1 A: The condition of either OC or OS is displayed individually. B: The condition of the entire refrigerant system is displayed.

Data on indoor unit system

No.	SW4 1-10 [0: OFF, 1: ON] (SW6-10: OFF)	Item	Display								Unit (A, B) ^{*1}		Remarks					
			LD1	LD2	LD3	LD4	LD5	LD6	LD7	LD8	OC	OS						
650	0101000101	IC28SC																
651	1101000101	IC29SC																
652	0011000101	IC30SC																
653	1011000101	IC31SC																
654	0111000101	IC32SC																
655	1111000101	IC33SC																
656	0000100101	IC34SC																
657	1000100101	IC35SC																
658	0100100101	IC36SC																
659	1100100101	IC37SC																
660	0010100101	IC38SC																
661	1010100101	IC39SC																
662	0110100101	IC40SC																
663	1110100101	IC41SC																
664	0001100101	IC42SC																
665	1001100101	IC43SC																
666	0101100101	IC44SC																
667	1101100101	IC45SC																
668	0011100101	IC46SC																
669	1011100101	IC47SC																
670	0111100101	IC48SC																
671	1111100101	IC49SC																
672	0000010101	IC50SC																

*1 A: The condition of either OC or OS is displayed individually. B: The condition of the entire refrigerant system is displayed.

Setting data

No.	SW4 1-10 [0: OFF, 1: ON] (SW6-10: OFF)	Item	Display								Unit (A, B) ^{*1}		Remarks
			LD1	LD2	LD3	LD4	LD5	LD6	LD7	LD8	OC	OS	
676	0010010101	INV board SW version	0.00 to 99.99								A	A	
688	0000110101	Current time	00:00 to 23:59								A	A	Hour: minute
689	1000110101	Current time -2	00.00 to 99.12/1 to 31										Year and month, and date alternate display
690	0100110101	Time of error detection 1	00:00 to 23:59										Hour: minute
691	1100110101	Time of error detection 1-2	00.00 to 99.12/1 to 31										Year and month, and date alternate display
692	0010110101	Time of error detection 2	00:00 to 23:59										Hour: minute
693	1010110101	Time of error detection 2-2	00.00 to 99.12/1 to 31										Year and month, and date alternate display
694	0110110101	Time of error detection 3	00:00 to 23:59										Hour: minute
695	1110110101	Time of error detection 3-2	00.00 to 99.12/1 to 31										Year and month, and date alternate display
696	0001110101	Time of error detection 4	00:00 to 23:59										Hour: minute
697	1001110101	Time of error detection 4-2	00.00 to 99.12/1 to 31										Year and month, and date alternate display
698	0101110101	Time of error detection 5	00:00 to 23:59										Hour: minute
699	1101110101	Time of error detection 5-2	00.00 to 99.12/1 to 31										Year and month, and date alternate display
700	0011110101	Time of error detection 6	00:00 to 23:59										Hour: minute
701	1011110101	Time of error detection 6-2	00.00 to 99.12/1 to 31										Year and month, and date alternate display

*1 A: The condition of either OC or OS is displayed individually. B: The condition of the entire refrigerant system is displayed.

Setting data

No.	SW4 1-10 [0: OFF, 1: ON] (SW6-10: OFF)	Item	Display								Unit (A, B)*1		Remarks
			LD1	LD2	LD3	LD4	LD5	LD6	LD7	LD8	OC	OS	
702	1234567890	Time of error detection 7	00:00 to 23:59								A	A	Hour: minute
703	0111110101	Time of error detection 7-2	00.00 to 99.12/1 to 31										Year and month, and date alternate display
704	0000001101	Time of error detection 8	00:00 to 23:59										Hour: minute
705	1000001101	Time of error detection 8-2	00.00 to 99.12/1 to 31										Year and month, and date alternate display
706	0100001101	Time of error detection 9	00:00 to 23:59										Hour: minute
707	1100001101	Time of error detection 9-2	00.00 to 99.12/1 to 31										Year and month, and date alternate display
708	0010001101	Time of error detection 10	00:00 to 23:59										Hour: minute
709	1010001101	Time of error detection 10-2	00.00 to 99.12/1 to 31										Year and month, and date alternate display
710	0110001101	Time of last data backup before error	00:00 to 23:59										Hour: minute
711	1110001101	Time of last data backup before error -2	00.00 to 99.12/1 to 31										Year and month, and date alternate display

*1 A: The condition of either OC or OS is displayed individually. B: The condition of the entire refrigerant system is displayed.

Data on indoor unit system

No.	SW4 1-10 [0: OFF, 1: ON] (SW6-10: OFF)	Item	Display								Unit (A, B) *1		Remarks		
			LD1	LD2	LD3	LD4	LD5	LD6	LD7	LD8	OC	OS			
714	0101001101	IC1 LEV opening								0000 to 9999					Fully open: 2000
715	1101001101	IC2 LEV opening								0000 to 9999					
716	0011001101	IC3 LEV opening								0000 to 9999					
717	1011001101	IC4 LEV opening								0000 to 9999					
718	0111001101	IC5 LEV opening								0000 to 9999					
719	1111001101	IC6 LEV opening								0000 to 9999					
720	0000101101	IC7 LEV opening								0000 to 9999					
721	1000101101	IC8 LEV opening								0000 to 9999					
722	0100101101	IC9 LEV opening								0000 to 9999					
723	1100101101	IC10 LEV opening								0000 to 9999					
724	0010101101	IC11 LEV opening								0000 to 9999					
725	1010101101	IC12 LEV opening								0000 to 9999					
726	0110101101	IC13 LEV opening								0000 to 9999					
727	1110101101	IC14 LEV opening								0000 to 9999					
728	0001101101	IC15 LEV opening								0000 to 9999					
729	1001101101	IC16 LEV opening								0000 to 9999					
730	0101101101	IC17 LEV opening								0000 to 9999					
731	1101101101	IC18 LEV opening								0000 to 9999					
732	0011101101	IC19 LEV opening								0000 to 9999					
733	1011101101	IC20 LEV opening								0000 to 9999					
734	0111101101	IC21 LEV opening								0000 to 9999					
735	1111101101	IC22 LEV opening								0000 to 9999					
736	000011101	IC23 LEV opening								0000 to 9999					
737	100011101	IC24 LEV opening								0000 to 9999					
738	0100011101	IC25 LEV opening								0000 to 9999					
739	1100011101	IC26 LEV opening								0000 to 9999					
740	0010011101	IC27 LEV opening								0000 to 9999					

*1 A: The condition of either OC or OS is displayed individually. B: The condition of the entire refrigerant system is displayed.

Data on indoor unit system

No.	SW4 1-10 [0: OFF, 1: ON] (SW6-10: OFF)	Item	Display								Unit (A, B)*1		Remarks		
			LD1	LD2	LD3	LD4	LD5	LD6	LD7	LD8	OC	OS			
764	1234567890	IC1 Operation mode													When WR2 is used, the four LDs on the left (LD1-4) display operation mode, and the four LDs on the right (LD5-LD8) display port address. (Displayed alternately every five seconds)
765	0011111101	IC2 Operation mode											B		
766	1011111101	IC3 Operation mode													
767	0111111101	IC4 Operation mode													
768	1111111101	IC5 Operation mode													

*1 A: The condition of either OC or OS is displayed individually. B: The condition of the entire refrigerant system is displayed.

Data on indoor unit system

No.	SW4 1-10 [0: OFF, 1: ON] (SW6-10: OFF)	Item	Display								Unit (A, B)*1		Remarks		
			LD1	LD2	LD3	LD4	LD5	LD6	LD7	LD8	OC	OS			
769	1000000011	IC6 Operation mode											B		When WR2 is used, the four LDs on the left (LD1-4) display operation mode, and the four LDs on the right (LD5-LD8) display port address. (Displayed alternately every five seconds)
770	0100000011	IC7 Operation mode													
771	1100000011	IC8 Operation mode													
772	0010000011	IC9 Operation mode													
773	1010000011	IC10 Operation mode													
774	0110000011	IC11 Operation mode													
775	1110000011	IC12 Operation mode													
776	0001000011	IC13 Operation mode													
777	1001000011	IC14 Operation mode													
778	0101000011	IC15 Operation mode													
779	1101000011	IC16 Operation mode													
780	0011000011	IC17 Operation mode													
781	1011000011	IC18 Operation mode													
782	0111000011	IC19 Operation mode													
783	1111000011	IC20 Operation mode													
784	0000100011	IC21 Operation mode													
785	1000100011	IC22 Operation mode													
786	0100100011	IC23 Operation mode													
787	1100100011	IC24 Operation mode													
788	0010100011	IC25 Operation mode													
789	1010100011	IC26 Operation mode													
790	0110100011	IC27 Operation mode													
791	1110100011	IC28 Operation mode													
792	0001100011	IC29 Operation mode													
793	1001100011	IC30 Operation mode													
794	0101100011	IC31 Operation mode													
795	1101100011	IC32 Operation mode													
796	0011100011	IC33 Operation mode													

0000 : Stop 0001 : Ventilation 0002 : Cooling 0003 : Heating 0004 : Dry

*1 A: The condition of either OC or OS is displayed individually. B: The condition of the entire refrigerant system is displayed.

Data on indoor unit system

No.	SW4 1-10 [0: OFF, 1: ON] (SW6-10: OFF)	Item	Display								Unit (A, B)*1		Remarks	
			LD1	LD2	LD3	LD4	LD5	LD6	LD7	LD8	OC	OS		
797	1011100011	IC34 Operation mode										B		When WR2 is used, the four LDs on the left (LD1-4) display operation mode, and the four LDs on the right (LD5-LD8) display port address. (Displayed alternately every five seconds)
798	0111100011	IC35 Operation mode												
799	1111100011	IC36 Operation mode												
800	0000010011	IC37 Operation mode												
801	1000010011	IC38 Operation mode												
802	0100010011	IC39 Operation mode												
803	1100010011	IC40 Operation mode												
804	0010010011	IC41 Operation mode												
805	1010010011	IC42 Operation mode												
806	0110010011	IC43 Operation mode												
807	1110010011	IC44 Operation mode												
808	0001010011	IC45 Operation mode												
809	1001010011	IC46 Operation mode												
810	0101010011	IC47 Operation mode												
811	1101010011	IC48 Operation mode												
812	0011010011	IC49 Operation mode												
813	1011010011	IC50 Operation mode												

0000 : Stop 0001 : Ventilation 0002 : Cooling 0003 : Heating 0004 : Dry

*1 A: The condition of either OC or OS is displayed individually. B: The condition of the entire refrigerant system is displayed.

Data on indoor unit system

No.	SW4 1-10 [0: OFF, 1: ON] (SW6-10: OFF)	Item	Display								Unit (A, B) ^{*1}		Remarks	
			LD1	LD2	LD3	LD4	LD5	LD6	LD7	LD8	OC	OS		
814	1234567890	IC1 filter												Hours since last maintenance [h]
815	0111010011	IC2 filter												
816	1111010011	IC3 filter												
817	0000110011	IC4 filter												
818	1000110011	IC5 filter												
819	0100110011	IC6 filter												
820	1100110011	IC7 filter												
821	0010110011	IC8 filter												
822	1010110011	IC9 filter												
823	0110110011	IC10 filter												
824	1110110011	IC11 filter												

*1 A: The condition of either OC or OS is displayed individually. B: The condition of the entire refrigerant system is displayed.

Data on indoor unit system

No.	SW4 1-10 [0: OFF, 1: ON] (SW6-10: OFF)	Item	Display										Unit (A, B)*1		Remarks		
			LD1	LD2	LD3	LD4	LD5	LD6	LD7	LD8	OC	OS					
825	100110011	IC12 filter															Hours since last maintenance [h]
826	010110011	IC13 filter															
827	110110011	IC14 filter															
828	001110011	IC15 filter															
829	101110011	IC16 filter															
830	011110011	IC17 filter															
831	111110011	IC18 filter															
832	000001011	IC19 filter															
833	100001011	IC20 filter															
834	010001011	IC21 filter															
835	110001011	IC22 filter															
836	001001011	IC23 filter															
837	101001011	IC24 filter															
838	011001011	IC25 filter															
839	111001011	IC26 filter															
840	0001001011	IC27 filter															
841	1001001011	IC28 filter															
842	0101001011	IC29 filter															
843	1101001011	IC30 filter															
844	0011001011	IC31 filter															
845	1011001011	IC32 filter															
846	0111001001	IC33 filter															
847	1111001011	IC34 filter															
848	0000101011	IC35 filter															
849	1000101011	IC36 filter															
850	0100101011	IC37 filter															
851	1100101011	IC38 filter															
852	0010101011	IC39 filter															

*1 A: The condition of either OC or OS is displayed individually. B: The condition of the entire refrigerant system is displayed.

Data on indoor unit system

No.	SW4 1-10 [0: OFF, 1: ON] (SW6-10: OFF)	Item	Display								Unit (A, B) ^{*1}		Remarks		
			LD1	LD2	LD3	LD4	LD5	LD6	LD7	LD8	OC	OS			
853	1234567890	IC40 filter													
854	1010101011	IC41 filter													
855	0110101011	IC42 filter													
856	1110101011	IC43 filter													
857	0001101011	IC44 filter													
858	1001101011	IC45 filter													
859	0101101011	IC46 filter													
860	1101101011	IC47 filter													
861	0011101011	IC48 filter													
862	1011101011	IC49 filter													
863	0111101011	IC50 filter													

*1 A: The condition of either OC or OS is displayed individually. B: The condition of the entire refrigerant system is displayed.

Other types of data

No.	SW4 1-10 [0: OFF, 1: ON] (SW6-10: OFF)	Item	Display								Unit (A, B)*1		Remarks
			LD1	LD2	LD3	LD4	LD5	LD6	LD7	LD8	OC	OS	
871	1110011011	U-phase current effective value 1	-99.9 to 999.9								A	A	The unit is [A]
872	0001011011	W-phase current effective value 1	-99.9 to 999.9								A	A	
873	1001011011	Power factor phase angle 1	-99.9 to 999.9								A	A	The unit is [deg]
880	0000111011	Control board Reset counter	0 to 254								A	A	The unit is [time]
881	1000111011	INV board Reset counter	0 to 254								A	A	

*1 A: The condition of either OC or OS is displayed individually. B: The condition of the entire refrigerant system is displayed.

Service Handbook

Model

PQHY-P72, P96, P120, P144, P168, P192, P216, P240T(Y)LMU-A1

PQHY-P144, P168, P192, P216, P240, P288, P312, P336, P360T(Y)SLMU-A1

PQRY-P72, P96, P120, P144, P168, P192, P216, P240T(Y)LMU-A1

PQRY-P144, P168, P192, P216, P240, P288, P312, P336T(Y)SLMU-A1

mitsubishi MITSUBISHI ELECTRIC CORPORATION

www.MitsubishiElectric.com